

# ENTSO-E HVDC UTILISATION AND UNAVAILABILITY STATISTICS 2021

FOR PUBLISHING | 16 August 2022

From: DISTAC Subgroup

---

ENTSO-E HVDC Utilisation and Unavailability Statistics 2021

Copyright © 2022 ENTSO-E AISBL

Report rendered 16 August 2022

## ENTSO-E Mission Statement

### Who we are

ENTSO-E, the European Network of Transmission System Operators for Electricity, is the association for the cooperation of the European transmission system operators (TSOs). The 42 member TSOs, representing 35 countries, are responsible for the secure and coordinated operation of Europe's electricity system, the largest interconnected electrical grid in the world. In addition to its core, historical role in technical cooperation, ENTSO-E is also the common voice of TSOs.

ENTSO-E brings together the unique expertise of TSOs for the benefit of European citizens by keeping the lights on, enabling the energy transition, and promoting the completion and optimal functioning of the internal electricity market, including via the fulfilment of the mandates given to ENTSO-E based on EU legislation.

### Our mission

ENTSO-E and its members, as the European TSO community, fulfil a common mission: Ensuring the security of the inter-connected power system in all time frames at pan-European level and the optimal functioning and development of the European interconnected electricity markets, while enabling the integration of electricity generated from renewable energy sources and of emerging technologies.

### Our vision

ENTSO-E plays a central role in enabling Europe to become the first climate-neutral continent by 2050 by creating a system that is secure, sustainable and affordable, and that integrates the expected amount of renewable energy, thereby offering an essential contribution to the European Green Deal. This endeavour requires sector integration and close cooperation among all actors.

Europe is moving towards a sustainable, digitalised, integrated and electrified energy system with a combination of centralised and distributed resources. ENTSO-E acts to ensure that this energy system keeps consumers at its centre and is operated and developed with climate objectives and social welfare in mind.

ENTSO-E is committed to use its unique expertise and system-wide view – supported by a responsibility to maintain the system's security – to deliver a comprehensive roadmap of how a climate-neutral Europe looks.

### Our values

ENTSO-E acts in solidarity as a community of TSOs united by a shared responsibility.

As the professional association of independent and neutral regulated entities acting under a clear legal mandate, ENTSO-E serves the interests of society by optimising social welfare in its dimensions of safety, economy, environment, and performance.

ENTSO-E is committed to working with the highest technical rigour as well as developing sustainable and innovative responses to prepare for the future and overcoming the challenges of keeping the power system secure in a climate-neutral Europe. In all its activities, ENTSO-E acts with transparency and in a trustworthy dialogue with legislative and regulatory decision makers and stakeholders.

### Our contributions

ENTSO-E supports the cooperation among its members at European and regional levels. Over the past decades, TSOs have undertaken initiatives to increase their cooperation in network planning, operation and market integration, thereby successfully contributing to meeting EU climate and energy targets.

To carry out its legally mandated tasks, ENTSO-E's key responsibilities include the following:

- › Development and implementation of standards, network codes, platforms and tools to ensure secure system and market operation as well as integration of renewable energy; › Assessment of the adequacy of the system in different timeframes;
- › Coordination of the planning and development of infrastructures at the European level (Ten-Year Network Development Plans, TYNDPs);
- › Coordination of research, development and innovation activities of TSOs;
- › Development of platforms to enable the transparent sharing of data with market participants.

ENTSO-E supports its members in the implementation and monitoring of the agreed common rules.

ENTSO-E is the common voice of European TSOs and provides expert contributions and a constructive view to energy debates to support policymakers in making informed decisions.

# Executive Summary

The HVDC links are important components for a stable operation of the Nordic and Baltic power system while supporting the commercial power trade in the European energy markets. Furthermore, the HVDC links can provide other important functions like voltage and emergency power support to the HVAC grid. Hence, the advantages of keeping the HVDC links in operation as much as possible are indisputable. The ENTSO-E HVDC Utilisation and Unavailability Statistics 2021 report aims to provide an overview of the Nordic and Baltic HVDC links as well as a detailed view of each individual link.

In 2021, 66.9 TWh of electric energy was transmitted through the Nordic and Baltic HVDC links, as seen in Figure 1. The total number of disturbance outages registered was 81, preventing 2.4 TWh of potential energy transmission, or 2.2 % of the total technical capacity ( $E_{max}$ ).

Maintenance outages amounted to 3.5 TWh, or 3.2 % of the total technical capacity ( $E_{max}$ ), and limitations reduced the transmission capacity by 4.0 TWh (3.7 % of the total technical HVDC transmission capacity).

The most utilised market connections in 2021 were FI-EE (76.9 %) and DK2-DE (71.4 %). Six other market connections reached a utilisation rate of 60–70 % while the five remaining market connections were utilised between 44–57 % of the maximum technical capacity ( $E_{max}$ ).

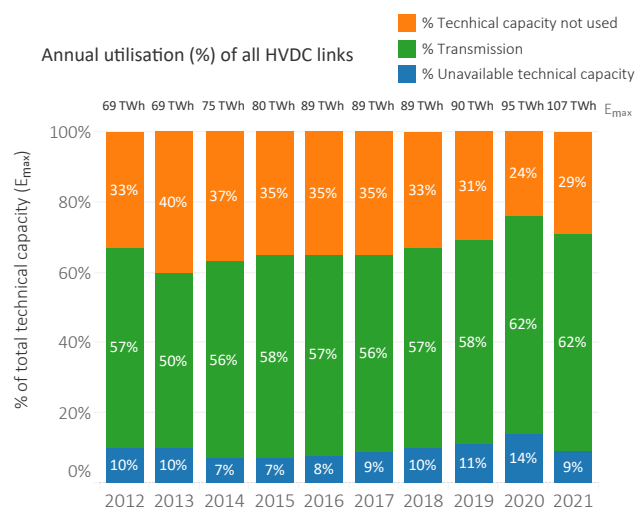

Figure 1: The annual utilisation of all HVDC links since 2012. Technical capacity not used is the amount of energy that has neither been transmitted nor been unavailable due to limitations or outages.

The percentage of unavailable technical capacity ( $E_U$ ) in 2021 dropped to the same levels as in 2017 (9 %), while the percentage of transmission ( $E_T$ ) was high compared to pre-

vious years. Table 1 shows that many of the HVDC links that have had a high share of unavailable capacity performed well in 2021, which is a good sign for the future.

The higher availability did not have a high impact on the utilisation rate, which increased from 61.6 % in 2020 to 62.3 % in 2021. On the other hand, the recently commissioned HVDC links have increased the total technical capacity ( $E_{max}$ ) available to the markets. Compared to 2020 when 58.8 TWh of electricity was transmitted through the HVDC links, 8.1 TWh or almost 14 % more was transmitted in 2021. The amount of transmitted energy has increased by almost 70 % since 2012–2014 when around 40 TWh was transmitted annually.

Table 1: Annual unavailability (%) per bidding zone.

	2012	2013	2014	2015	2016	2017	2018	2019	2020	2021
DK1-NL								5%	29%	10%
DK2-DE	6%	4%	3%	5%	10%	14%	26%	4%	30%	5%
DK2-DK1	3%	10%	5%	2%	3%	2%	2%	2%	0%	1%
FI-EE	3%	5%	15%	6%	4%	1%	4%	2%	3%	1%
FI-SE3	27%	17%	5%	9%	2%	1%	1%	5%	1%	13%
LT-PL					14%	10%	6%	4%	9%	13%
NO2-DE										10%
NO2-DK1	2%	8%	11%	6%	5%	18%	13%	27%	24%	8%
NO2-NL	3%	19%	5%	4%	8%	8%	14%	13%	17%	27%
RU-FI	10%	1%	0%	0%	1%	2%	5%	5%	12%	8%
SE3-DK1	5%	11%	16%	17%	5%	7%	4%	16%	17%	11%
SE4-DE	22%	18%	7%	12%	20%	27%	36%	26%	19%	10%
SE4-LT					26%	16%	22%	8%	5%	6%
SE4-PL	0%	3%	7%	7%	15%	6%	4%	14%	13%	9%
Grand Total	10%	10%	7%	7%	8%	9%	10%	11%	14%	9%

The HVDC links with most unavailable technical capacity due to outages were, in descending order, NorNed, LitPol Link, Konti-Skan 1 and COBRACable. NorNed had a major cable fault on the Dutch side in mid-January until March. Most of LitPol Link’s unavailable capacity was due to longer than expected maintenances due to unplanned replacement of a converter transformer’s bushing. The unavailable capacity of Konti-Skan 1 was due to a cable fault on land cable, and the unavailable capacity of COBRACable was due to the submarine cable fault from 2020 that also covered some of 2021 and planned maintenance to cover some exposed offshore cable. Fenno-Skan 1 had more than usual unavailability due to disturbance outages.

The unavailability of NordLink 1 and 2 is due testing and repairs during the first year after commissioning

Limitations were prominent on Skagerrak 2 (22 % of the technical capacity), Fenno-Skan 2 (16 %), Skagerrak 3 (9 %) and Baltic Cable (8 %). Skagerrak 2 and 3 were limited in the north direction because of the multiple cable faults on Skagerrak 4 in the recent years.

# Table of contents

<b>Executive Summary</b>	<b>i</b>	5.3.12 NordLink 1 . . . . .	37
<b>Table of contents</b>	<b>ii</b>	5.3.13 NordLink 2 . . . . .	38
<b>List of Figures</b>	<b>iii</b>	5.3.14 NorNed . . . . .	39
<b>List of Tables</b>	<b>v</b>	5.3.15 Skagerrak 1 . . . . .	41
<b>1 Introduction and background</b>	<b>1</b>	5.3.16 Skagerrak 2 . . . . .	43
<b>2 Scope</b>	<b>2</b>	5.3.17 Skagerrak 3 . . . . .	45
2.1 Contact persons . . . . .	2	5.3.18 Skagerrak 4 . . . . .	47
<b>3 Methods and definitions</b>	<b>3</b>	5.3.19 Storebaelt . . . . .	49
<b>4 Technical details of the HVDC links</b>	<b>4</b>	5.3.20 SwePol . . . . .	51
<b>5 Results</b>	<b>6</b>	5.3.21 Vyborg Link . . . . .	53
5.1 Overview of 2021 . . . . .	6	<b>References</b>	<b>56</b>
5.2 Overview of years 2012–2021 . . . . .	10	<b>Glossary</b>	<b>57</b>
5.3 Individual presentations of each HVDC link	14	<b>Appendices</b>	<b>58</b>
5.3.1 Baltic Cable . . . . .	15	<b>A Schematic presentation of HVDC links</b>	<b>59</b>
5.3.2 COBRACable . . . . .	17	<b>B DISTAC/CIGRE origin of event classification</b>	<b>60</b>
5.3.3 EstLink 1 . . . . .	19	<b>C Contact persons</b>	<b>61</b>
5.3.4 EstLink 2 . . . . .	21	<b>D Sorted overview of utilisation and unavailability for all HVDC links</b>	<b>62</b>
5.3.5 Fenno-Skan 1 . . . . .	23	<b>E Additional figures</b>	<b>64</b>
5.3.6 Fenno-Skan 2 . . . . .	25	E.1 Annual utilisation per type of HVDC converter	64
5.3.7 Kontek . . . . .	27	E.2 Additional figures with percentages of hours unavailable . . . . .	65
5.3.8 Konti-Skan 1 . . . . .	29	E.3 Additional figures with origin of event . . . . .	68
5.3.9 Konti-Skan 2 . . . . .	31		
5.3.10 LitPol Link . . . . .	33		
5.3.11 NordBalt . . . . .	35		

## List of Figures

1	Annual utilisation of all HVDC links in percentages . . . . .	i	5.29	Annual percentage of unavailability hours for Fenno-Skan 1 . . . . .	24
1.1	Map of HVDC links in this report . . . . .	1	5.30	Annual number of outages for Fenno-Skan 1 . . . . .	24
3.1	The hierarchy of the availability and utilisation categories used in the HVDC statistics . . . . .	3	5.31	Fenno-Skan 2 availability and utilisation monthly . . . . .	25
5.1	Utilisation (%) by category for each HVDC link in 2021 . . . . .	7	5.32	Annual utilisation of Fenno-Skan 2 . . . . .	26
5.2	Utilisation (%) by category for each market connection in 2021 . . . . .	8	5.33	Annual percentage of unavailability hours for Fenno-Skan 2 . . . . .	26
5.3	Unavailable technical capacity (%) for each HVDC link in 2021 . . . . .	9	5.34	Annual number of outages for Fenno-Skan 2 . . . . .	26
5.4	The number of outages for each HVDC link in 2021. . . . .	9	5.35	Kontek availability and utilisation monthly . . . . .	27
5.5	Annual utilisation percentage of all HVDC links . . . . .	10	5.36	Annual utilisation of Kontek . . . . .	28
5.6	Annual utilisation (MWh) of all HVDC links . . . . .	11	5.37	Annual percentage of unavailability hours for Kontek . . . . .	28
5.7	Annual utilisation rate grouped by utilisation percentage . . . . .	11	5.38	Annual number of outages for Kontek . . . . .	28
5.8	Annual unavailable technical capacity (%) by unavailability category . . . . .	12	5.39	Konti-Skan 1 availability and utilisation monthly . . . . .	29
5.9	Annual hours (%) affected by limitations or outages . . . . .	12	5.40	Annual utilisation of Konti-Skan 1 . . . . .	30
5.10	Map of HVDC links in this report . . . . .	14	5.41	Annual percentage of unavailability hours for Konti-Skan 1 . . . . .	30
5.11	Baltic Cable availability and utilisation monthly . . . . .	15	5.42	Annual number of outages for Konti-Skan 1 . . . . .	30
5.12	Annual utilisation of Baltic Cable . . . . .	16	5.43	Konti-Skan 2 availability and utilisation monthly . . . . .	31
5.13	Annual percentage of unavailability hours for Baltic Cable . . . . .	16	5.44	Annual utilisation of Konti-Skan 2 . . . . .	32
5.14	Annual number of outages for Baltic Cable . . . . .	16	5.45	Annual percentage of unavailability hours for Konti-Skan 2 . . . . .	32
5.15	COBRACable availability and utilisation monthly . . . . .	17	5.46	Annual number of outages for Konti-Skan 2 . . . . .	32
5.16	Annual utilisation of COBRACable . . . . .	18	5.47	LitPol Link availability and utilisation monthly . . . . .	33
5.17	Annual percentage of unavailability hours for COBRACable . . . . .	18	5.48	Annual utilisation of LitPol Link . . . . .	34
5.18	Annual number of outages for COBRACable . . . . .	18	5.49	Annual percentage of unavailability hours for LitPol Link . . . . .	34
5.19	EstLink 1 availability and utilisation monthly . . . . .	19	5.50	Annual number of outages for LitPol Link . . . . .	34
5.20	Annual utilisation of EstLink 1 . . . . .	20	5.51	NordBalt availability and utilisation monthly . . . . .	35
5.21	Annual percentage of unavailability for Est-Link 1 . . . . .	20	5.52	Annual utilisation of NordBalt . . . . .	36
5.22	Annual number of outages for EstLink 1 . . . . .	20	5.53	Annual percentage of unavailability hours for NordBalt . . . . .	36
5.23	EstLink 2 availability and utilisation monthly . . . . .	21	5.54	Annual number of outages for NordBalt . . . . .	36
5.24	Annual utilisation of EstLink 2 . . . . .	22	5.55	NordLink 1 availability and utilisation monthly . . . . .	37
5.25	Annual percentage of unavailability hours for EstLink 2 . . . . .	22	5.56	NordLink 2 availability and utilisation monthly . . . . .	38
5.26	Annual number of outages for EstLink 2 . . . . .	22	5.57	NorNed availability and utilisation monthly . . . . .	39
5.27	Fenno-Skan 1 availability and utilisation monthly . . . . .	23	5.58	Annual utilisation of NorNed . . . . .	40
5.28	Annual utilisation of Fenno-Skan 1 . . . . .	24	5.59	Annual percentage of unavailability hours for NorNed . . . . .	40
			5.60	Annual number of outages for NorNed . . . . .	40
			5.61	Skagerrak 1 availability and utilisation monthly . . . . .	41
			5.62	Annual utilisation of Skagerrak 1 . . . . .	42
			5.63	Annual percentage of unavailability hours for Skagerrak 1 . . . . .	42
			5.64	Annual number of outages for Skagerrak 1 . . . . .	42
			5.65	Skagerrak 2 availability and utilisation monthly . . . . .	43
			5.66	Annual utilisation of Skagerrak 2 . . . . .	44

5.67 Annual percentage of unavailability hours for Skagerrak 2 . . . . .	44	A.2 A schematic presentation of a converter station of a VSC HVDC link . . . . .	59
5.68 Annual number of outages for Skagerrak 2 . . . . .	44	D.1 Utilisation and unavailability for each HVDC link, sorted by unavailable technical capacity . . . . .	62
5.69 Skagerrak 3 availability and utilisation monthly . . . . .	45	D.2 Utilisation and unavailability for each HVDC link, sorted by transmission . . . . .	63
5.70 Annual utilisation of Skagerrak 3 . . . . .	46	D.3 Utilisation and unavailability for each HVDC link, sorted by technical capacity not used . . . . .	63
5.71 Annual percentage of unavailability hours for Skagerrak 3 . . . . .	46	E.1 Annual utilisation of all LCC HVDC links . . . . .	64
5.72 Annual number of outages for Skagerrak 3 . . . . .	46	E.2 Annual utilisation of all VSC HVDC links . . . . .	64
5.73 Skagerrak 4 availability and utilisation monthly . . . . .	47	E.3 Hours (%) limited due to seasonal causes . . . . .	65
5.74 Annual utilisation of Skagerrak 4 . . . . .	48	E.4 Hours (%) limited by limitation origin and type annually . . . . .	65
5.75 Annual percentage of unavailability hours for Skagerrak 4 . . . . .	48	E.5 Hours (%) limited by limitation origin and type for each HVDC link . . . . .	66
5.76 Annual number of outages for Skagerrak 4 . . . . .	48	E.6 Hours (%) limited by limitation origin and type for each market connection . . . . .	66
5.77 Storebaelt availability and utilisation monthly . . . . .	49	E.7 Hours (%) with planned maintenance by primary cause for each HVDC link and the corresponding annual values for all HVDC links combined . . . . .	67
5.78 Annual utilisation of Storebaelt . . . . .	50	E.8 Number of disturbance outages divided by the number of HVDC links, grouped by origin of event . . . . .	68
5.79 Annual percentage of unavailability hours for Storebaelt . . . . .	50	E.9 Annual unavailable capacity due to disturbances outages by origin of event for all HVDC links . . . . .	68
5.80 Annual number of outages for Storebaelt . . . . .	50	E.10 Annual unavailable capacity due to maintenance outages by primary cause for all HVDC links . . . . .	70
5.81 SwePol availability and utilisation monthly . . . . .	51	E.11 Annual unavailable capacity due to corrective maintenance outages for all HVDC links, distributed by origin of event, and the annual average number of them . . . . .	70
5.82 Annual utilisation of SwePol . . . . .	52		
5.83 Annual percentage of unavailability hours for SwePol . . . . .	52		
5.84 Annual number of outages for SwePol . . . . .	52		
5.85 Vyborg Link availability and utilisation monthly . . . . .	53		
5.86 Vyborg Link availability and utilisation monthly . . . . .	54		
5.87 Annual utilisation of Vyborg Link . . . . .	55		
5.88 Annual percentage of unavailability hours for Vyborg Link . . . . .	55		
5.89 Annual number of outages for Vyborg Link . . . . .	55		
A.1 A schematic presentation of a converter station of a LCC HVDC link . . . . .	59		

# List of Tables

1	Annual unavailability (%) per bidding zone . . . . .	i	5.14 NordBalt monthly distribution of technical capacity ( $E_{max}$ ) . . . . .	35
4.1	Main properties of the HVDC links . . . . .	4	5.15 NordLink 1 monthly distribution of technical capacity ( $E_{max}$ ) . . . . .	37
4.2	Technical details of the HVDC links . . . . .	5	5.16 NordLink 2 monthly distribution of technical capacity ( $E_{max}$ ) . . . . .	38
5.1	Annual utilisation (%) of HVDC links per market connection . . . . .	13	5.17 NorNed monthly distribution of technical capacity ( $E_{max}$ ) . . . . .	39
5.2	Annual unavailability (%) of HVDC links per market connection . . . . .	13	5.18 Skagerrak 1 monthly distribution of technical capacity ( $E_{max}$ ) . . . . .	41
5.3	Annual technical capacity not used (%) of HVDC links per market connection . . . . .	13	5.19 Skagerrak 2 monthly distribution of technical capacity ( $E_{max}$ ) . . . . .	43
5.4	Baltic Cable monthly distribution of technical capacity ( $E_{max}$ ) . . . . .	15	5.20 Skagerrak 3 monthly distribution of technical capacity ( $E_{max}$ ) . . . . .	45
5.5	COBRACable monthly distribution of technical capacity ( $E_{max}$ ) . . . . .	17	5.21 Skagerrak 4 monthly distribution of technical capacity ( $E_{max}$ ) . . . . .	47
5.6	EstLink 1 monthly distribution of technical capacity ( $E_{max}$ ) . . . . .	19	5.22 Storebaelt monthly distribution of technical capacity ( $E_{max}$ ) . . . . .	49
5.7	EstLink 2 monthly distribution of technical capacity ( $E_{max}$ ) . . . . .	21	5.23 SwePol monthly distribution of technical capacity ( $E_{max}$ ) . . . . .	51
5.8	Fenno-Skan 1 monthly distribution of technical capacity ( $E_{max}$ ) . . . . .	23	5.24 Vyborg Link monthly distribution of technical capacity ( $E_{max}$ ) . . . . .	53
5.9	Fenno-Skan 2 monthly distribution of technical capacity ( $E_{max}$ ) . . . . .	25	5.25 Vyborg Link monthly distribution of technical capacity ( $E_{max}$ ) . . . . .	54
5.10	Kontek monthly distribution of technical capacity ( $E_{max}$ ) . . . . .	27	B.1 The origin of event categories and subcategories and the corresponding CIGRE outage codes . . . . .	60
5.11	Konti-Skan 1 monthly distribution of technical capacity ( $E_{max}$ ) . . . . .	29	E.1 Annual unavailable capacity due to disturbances outages by origin of event and subcategory for all HVDC links . . . . .	69
5.12	Konti-Skan 2 monthly distribution of technical capacity ( $E_{max}$ ) . . . . .	31		
5.13	LitPol monthly distribution of technical capacity ( $E_{max}$ ) . . . . .	33		



This page is intentionally left blank.

# 1 Introduction and background

The ENTSO-E HVDC Utilisation and Unavailability Statistics 2021 presents the availability and utilisation of HVDC links connected to the Nordic and Baltic power system in 2021. This includes an overview of availability and utilisation for the HVDC links, information about disturbances and unavailability and individual presentations of the performance of each HVDC link.

The first version of the HVDC statistics for utilisation and unavailability was published in 2011 as an addition to the Nordic Grid Disturbance and Fault Statistics 2010 [1]. At that time, the report covered only the Nordic power systems and presented 8 HVDC links. For the statistical year 2012, the HVAC Grid Disturbance Report and HVDC statistics were separated into two reports, which is the format of the reports today. In present time, this report includes 20 HVDC links connected to the Nordic and Baltic countries.

The total HVDC transmission capacity connected to the Nordic and Baltic power systems in 2021 is 13.9 GW, which makes the annual transmission capacity 121.6 TWh. Most of the HVDC links connect the Nordic synchronous system to other systems. A map of the bidding zones and each HVDC link is presented in Figure 1.1.

The total HVDC transmission capacity connected to the Nordic and Baltic power systems in 2021 is 13.9 GW, which makes the annual transmission capacity 121.6 TWh. Most of the HVDC links connect the Nordic synchronous system to other systems. A map of the bidding zones and each HVDC link is presented in Figure 1.1.

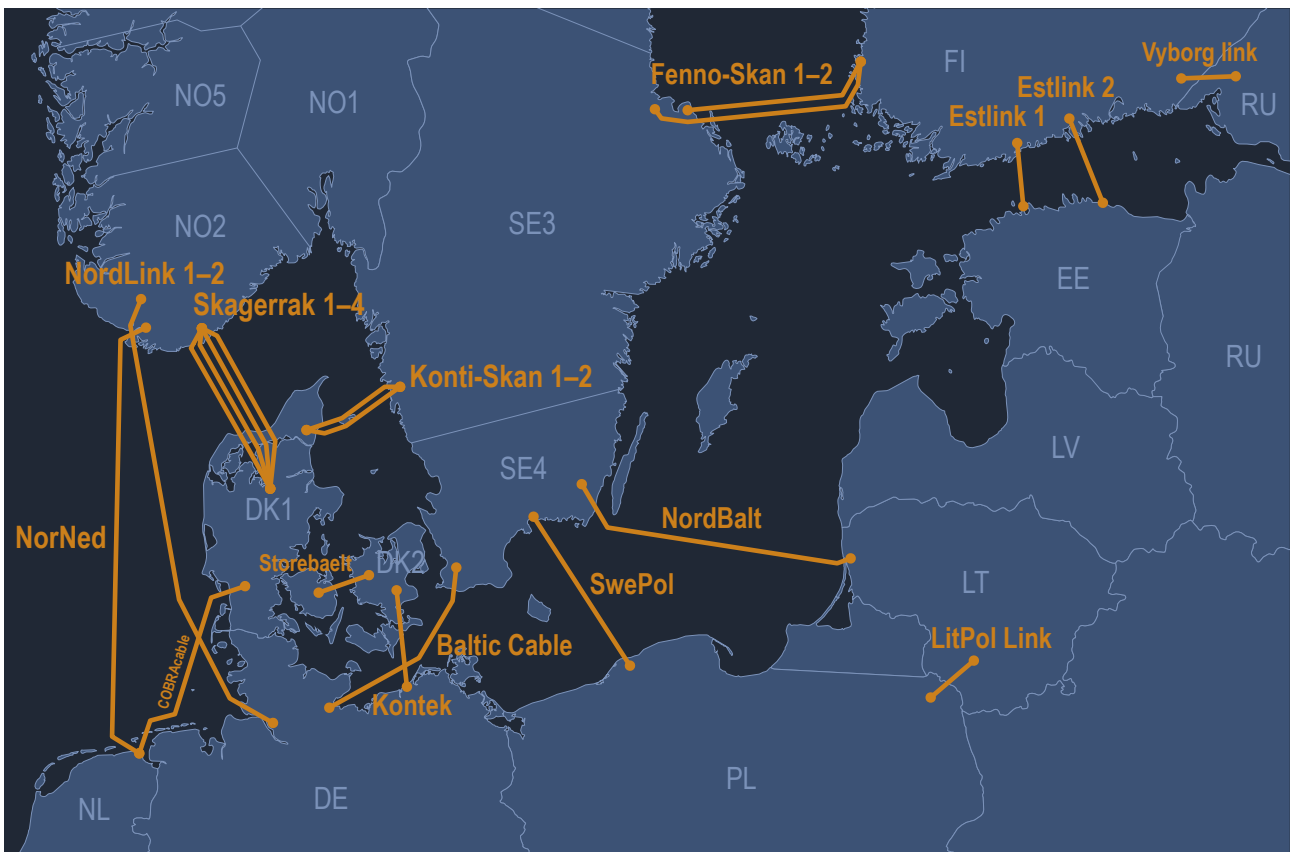

Figure 1.1: A map of the 20 HVDC links included in this report and the bidding zones in the area.

## 2 Scope

The ENTSO-E HVDC Utilisation and Unavailability Statistics 2021 presents a macro view of the availability and utilisation of each HVDC link, including disturbance, maintenance and other outage events as well as limitations. Limitations originating from maintenance work done in the AC grid are also included if they affect the power transfer of an HVDC connection. Furthermore, disturbance outages are more thoroughly examined than other events.

The scope of the Report is different from the CIGRE performance survey data [2], which focuses mainly on outages, faults and disturbances of the HVDC systems. CIGRE statistics give more details about the condition and performance of the HVDC assets themselves, including forced and scheduled outages, thyristor and transistor failure rates, commutation failures, and so on. On the other hand, DISTAC HVDC statistics cover more divergent performance and availability data and partly going deeper into classifi-

cation, consequences and outage reasons.

The HVDC WG of NordAM<sup>1</sup> and the DISTAC group have together developed the DISTAC HVDC outage and utilization data collection so that more detailed HVDC performance data analysis will be enabled in future. Together they also updated the HVDC performance data collection guidelines according to the new features.

### 2.1 Contact persons

Each country is represented by at least one contact person who is responsible for the statistical information of the corresponding country. The contact person can provide additional information concerning the HVDC availability and utilisation statistics. The relevant contact information is given in Appendix C.

---

<sup>1</sup>The five Nordic Transmission System Operators (TSOs) founded a Nordic Asset Management Forum (NordAM) in 2009 with the main goal to increase cooperation, jointly influence, build up knowledge, create networks as well as carry out agreed surveys and development tasks within the field of Asset Management. The HVDC working group was established after a very successful task force work done in 2017.

### 3 Methods and definitions

To compare the utilisation and availability between HVDC links, different ways of using them must be discerned and understood. This chapter explains the availability and utilisation categories used to differentiate between means of utilising HVDC links. The hierarchy of the categories is illustrated in Figure 3.1.

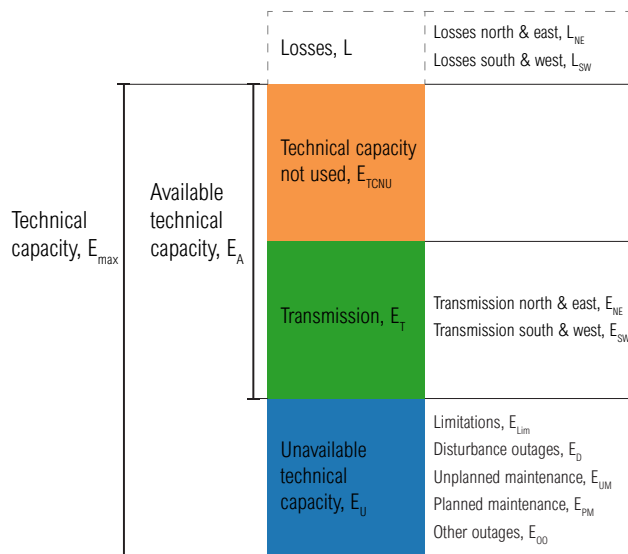

Figure 3.1: The hierarchy of the availability and utilisation categories used in the HVDC statistics.

The *technical capacity* ( $E_{max}$ ) of an HVDC link is the maximum energy that can be physically received through the HVDC link to the converter station, excluding all HVDC link losses, during a year. The technical capacity is divided into two categories: *available technical capacity* ( $E_A$ ) and *unavailable technical capacity* ( $E_U$ ).

The *available technical capacity* ( $E_A$ ) is divided into technical capacity that has been *transmitted* ( $E_T$ ) and into technical capacity that could have been transmitted/utilised that is, *technical capacity not used* ( $E_{TGNU}$ ).

*Transmitted energy* ( $E_T$ ) is the sum of transmitted energy in both directions of the HVDC link. Energy transferred to the north or east side of the HVDC link is called *transmission north and east* ( $E_{NE}$ ) (previously export), and energy transferred to the south or west side of the HVDC link is called *transmission south and west* ( $E_{SW}$ ) (previously import). It does not include *losses* ( $L$ ) that is, the energy losses in any of the HVDC link components during transmission. It should be noted that these values are measurements and therefore considered factual.

*Technical capacity not used* ( $E_{TGNU}$ ) is the residual energy after transmission, outages and limitations have been accounted for. The electricity market does not need the added transfer in most of these cases.

The *unavailable technical capacity* ( $E_U$ ) is the part of the *technical capacity* ( $E_{max}$ ) that could not be utilised. It has five subcategories: *limitations* ( $E_{Lim}$ ), *disturbance outages* ( $E_D$ ), *unplanned maintenance* ( $E_{UM}$ ), *planned maintenance* ( $E_{PM}$ ) and *other outages* ( $E_{OO}$ ). An outage occurs when the HVDC link is fully disconnected from the system and the transfer capacity is reduced to zero. A limitation occurs when the capacity of the link has been reduced by between 0–100 %. Limitations and the outages are described in more detail below.

A *limitation* ( $E_{Lim}$ ) is a condition when the transmission capacity of an HVDC link is limited that is, the power transmission capacity of the link is less than the rated power. The limitation is always motivated from a technical perspective, but not always concerning the link itself. The most common causes of limitations are:

- faults on any HVDC link component that do not cause a total outage;
- faults, congestions or outages in the AC grid causing a limitation in the transmission capacity of the link;
- seasonal variations on the transmission capacity of the HVDC link.

Note that a limitation is counted for an hour only if there was transmission in the direction of the limitation and the sum of transmission and unavailable technical capacity is more than 90 % of the rated capacity. The reason to this is to only include limitations that have truly impacted the transmission of a HVDC link. Limitations that do not meet this requirement become *technical capacity not used* ( $E_{TGNU}$ ) instead.

*Disturbance outages* ( $E_D$ ) are total outages due to a fault on the HVDC link or in the AC-grid causing a total outage of the link. A disturbance outage occurs when the protection trips the link or, in rare cases, disconnected manually. Manual disconnection is usually categorised as unplanned maintenance.

*Unplanned maintenance outages* ( $E_{UM}$ ) occurs when the link is manually disconnected for emergency or urgent repair. In general, unplanned maintenance are outages that cannot wait until the next scheduled maintenance.

*Planned maintenance outages* ( $E_{PM}$ ) are total outages due to all technically motivated actions on the HVDC link or in the AC grid intended to retain an entity in, or restore it to, a state where it can perform its required function.

*Other outages* ( $E_{OO}$ ) are outages due to any other reason except those mentioned above. This could be, for example, black start or other tests or when the markets do not need the transmission capacity of the link and the link is disconnected.

## 4 Technical details of the HVDC links

Table 4.1 presents the main properties of the HVDC links while Table 4.2 presents the technical properties of the HVDC lines.

Schematic presentations of the HVDC links and their converter stations, both for line-commutated converters (LCC) and voltage-source converters (VSC) are presented in Appendix A.

Table 4.1: Main properties of the HVDC links.

Link	Commissioning year	Market connection	HVDC converter type	Rated power, monopolar (MW)	Parallel monopolar capacity (MW)	Bipolar capacity
Baltic Cable	1994	Yes	LCC	600		
COBRACable	2019	Yes	VSC	700		
EstLink 1	2006	Yes	VSC	350	1000	
EstLink 2	2014	Yes	LCC	650		
Fenno-Skan 1	1989	Yes	LCC	400	1200	1200
Fenno-Skan 2	2011	Yes	LCC	800		
Kontek	1995	Yes	LCC	600		
Konti-Skan 1 <sup>1</sup>	2008	Yes	LCC	357.5		715
Konti-Skan 2 <sup>1</sup>	1988	Yes	LCC	357.5		
LitPol Link	2015	Yes	LCC	500		
NordBalt	2016	Yes	VSC	700		
NordLink 1–2	2020	Yes	VSC	700×2		1400
NorNed	2008	Yes	LCC	700		
Skagerrak 1	1977	Yes	LCC	236	1000	1000
Skagerrak 2	1977	Yes	LCC	236		
Skagerrak 3	1993	Yes	LCC	478		
Skagerrak 4	2014	Yes	VSC	682		
Storebaelt	2010	Yes	LCC	600		
SwePol	2000	Yes	LCC	600		
Vyborg Link <sup>2</sup>	1981, 1982, 1984, 2000	Partly	LCC	1400		
<b>Total</b>				<b>10972</b>	<b>3940</b>	<b>2200</b>

<sup>1</sup> Konti-Skan bipole can export 740 MW and the import capacity is 715 MW. This counts in both directions since the reference-point is now on the importing side.

<sup>2</sup> Each commissioning increased capacity by 350 MW. However, the total commercial capacity of Vyborg Link is 1300 MW. Fingrid Oyj, the Finnish transmission system operator, allocates 100 MW for reserves.

Table 4.2: Technical details of the HVDC links

Link	Physical length (km)	Length of mass cable (km)	Length of PEX cable (km)	Length of DC overhead line (km)	Length of DC back-to-back connection (km)
Baltic Cable	262	250		12	
COBRACable	325	325	650 (2×325)	0	
EstLink 1	105		210 (2×105)		
EstLink 2	171	157		14	
Fenno-Skan 1	233	200		33	
Fenno-Skan 2	299	196		103	
Kontek	160		160		
Konti-Skan 1	150	89		61	
Konti-Skan 2	150	89		61	
LitPol Link	< 1				< 1
NordBalt	450		2×450		
NordLink 1–2	623			53	
NorNed	580	580			
Skagerrak 1	212.5	133.6		78.5	
Skagerrak 2	211.4	132.9		78.5	
Skagerrak 3	212.9	134.4		78.5	
Skagerrak 4	226	226			
Storebaelt	57	57			
SwePol	254	254			
Vyborg Link	< 1				< 1

## 5 Results

This chapter presents the utilisation and unavailability of all the HVDC links as well as individual presentations of each HVDC link connected to the Nordic and Baltic power system.

Section 5.1 provides an overview of the HVDC links for the year 2021 and Section 5.2 provides an overview of the years 2012–2021. Section 5.3 presents the availability and utilisation of each HVDC link for the year 2021 as well as an annual overview of the utilisation and a trend of the utilisation and the number of outages for the years 2012–2021.

### 5.1 Overview of 2021

Figure 5.1 presents the utilisation and unavailability (%) of each HVDC link in 2021. It should be noted that the usages of the links show big variations. Most links are market dependent, some are mostly used in one direction, and some are used for technical reasons to control power flow for system stability according to agreements. Sorted views of Figure 5.1 are shown in Appendix D.

In 2021, 66.9 TWh of electric energy was transmitted through the Nordic and Baltic HVDC links. The total number of disturbance outages registered was 81, preventing 2.4 TWh of potential energy transmission, or 2.2 % of the total technical capacity ( $E_{\max}$ ).

Maintenance outages amounted to 3.5 TWh, or 3.2 % of the total technical capacity ( $E_{\max}$ ), and limitations reduced the transmission capacity by 4.0 TWh (3.7 % of the total technical HVDC transmission capacity).

The most utilised market connections in 2021 were FI–EE (76.9 %) and DK2–DE (71.4 %). Six other market connections reached a utilisation rate of 60–70 % while the five remaining market connections were utilised between 44–57 % of the maximum technical capacity ( $E_{\max}$ ).

Figure 5.2 compares the availability and utilisation of the HVDC links between bidding zones. That is, it measures the utilisation of the energy transfer capacity between the bidding zones ignoring the performance of individual links. However, the number of HVDC links connecting different bidding zones varies. A map portraying the bidding zones and each HVDC link is presented in Figure 5.10.

Figure 5.3 presents the percentage unavailable technical capacity ( $E_U$ ) of the annual technical capacity ( $E_{\max}$ ) due to the disturbance outages. Figure 5.4 presents the number of all disturbance, maintenance and other outages. The explanations for the most notable unavailability in 2021 are listed below. Further details are presented in Section 5.3.

#### Review of notable unavailable technical capacity 2021

The HVDC links with most unavailable technical capacity due to outages were, in descending order, NorNed, LitPol Link, Konti-Skan 1 and COBRACable. NorNed had a major cable fault on the Dutch side in mid-January until March. Most of LitPol Link's unavailable capacity was due to longer than expected maintenances due to unplanned replacement of a converter transformer's bushing. The unavailable capacity of Konti-Skan 1 was due to a cable fault on land cable, and the unavailable capacity of COBRACable was due to the submarine cable fault from 2020 that also covered some of 2021 and planned maintenance to cover some exposed offshore cable. Fenno-Skan 1 had more than usual unavailability due to disturbance outages.

The unavailability of NordLink 1 and 2 is due testing and repairs during the first year after commissioning.

Limitations were prominent on Skagerrak 2 (22 % of the technical capacity), Fenno-Skan 2 (16 %), Skagerrak 3 (9 %) and Baltic Cable (8 %). Skagerrak 2 and 3 were limited in the north direction because of the multiple cable faults on Skagerrak 4 in the recent years.

Utilisation (%) by category for each HVDC link in 2021

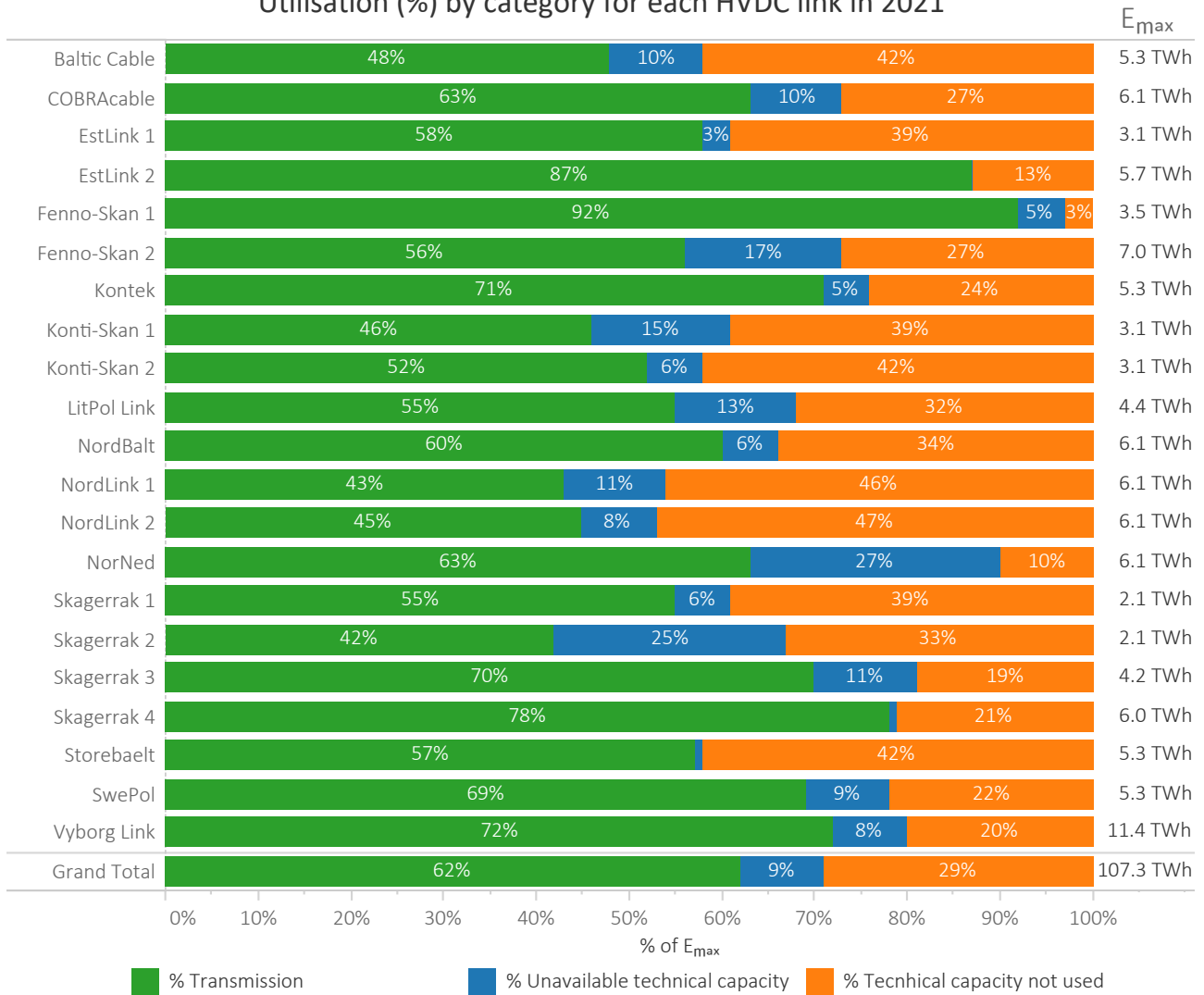

Figure 5.1: Utilisation (%) by category for each HVDC link in 2021. The unavailable technical capacity ( $E_U$ ) is the amount of technical capacity ( $E_{max}$ ) not available due to limitations or outages. Transmission ( $E_T$ ) is the amount of technical capacity ( $E_{max}$ ) transmitted through the HVDC link. Technical capacity not used ( $E_{TCNU}$ ) is the amount of energy that has not been transmitted or been unavailable due to limitations or outages. More detailed explanations can be read in Chapter 3.



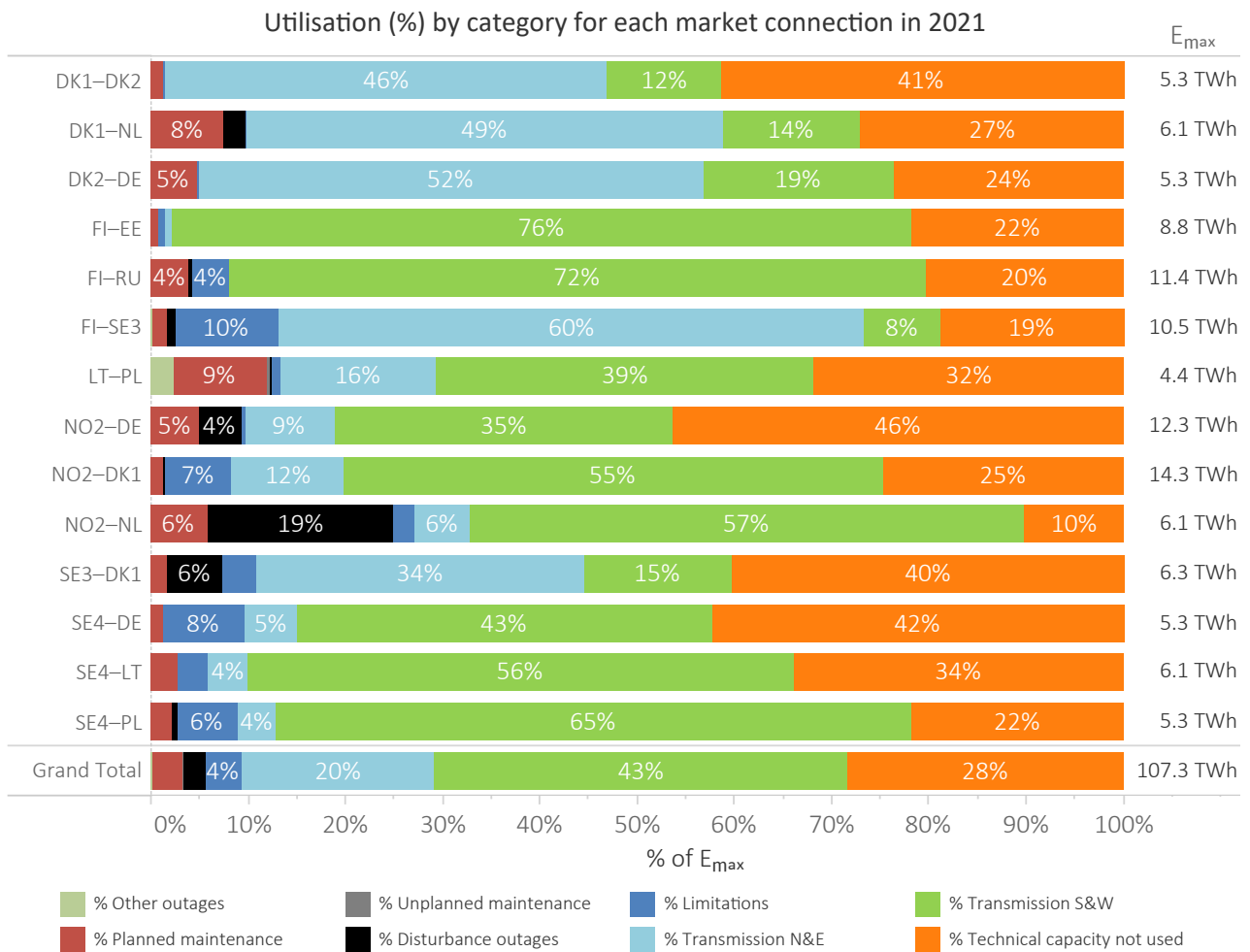

Figure 5.2: Utilisation (%) by category for each market connection in 2021. The categories are explained in Chapter 3.

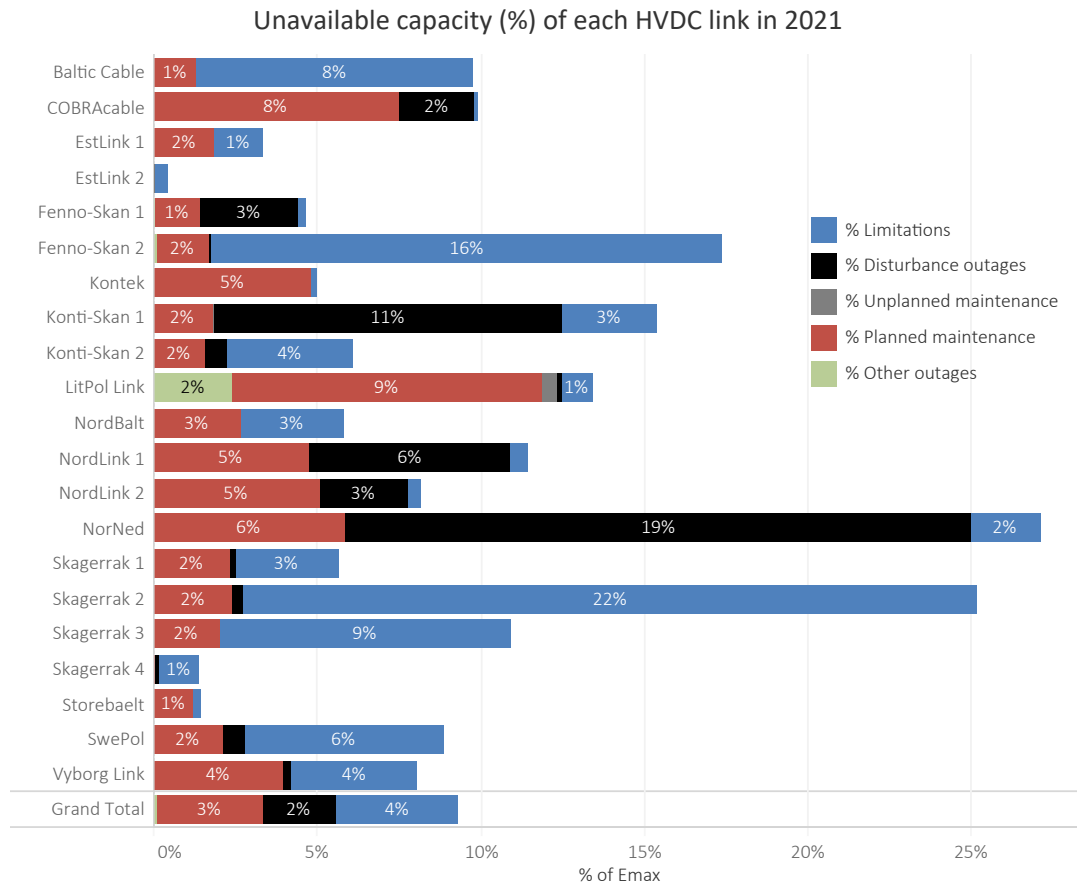

Figure 5.3: Unavailable technical capacity (%) for each HVDC link in 2021. The used unavailability categories are limitations, disturbance outages, unplanned and planned maintenances and other outages.

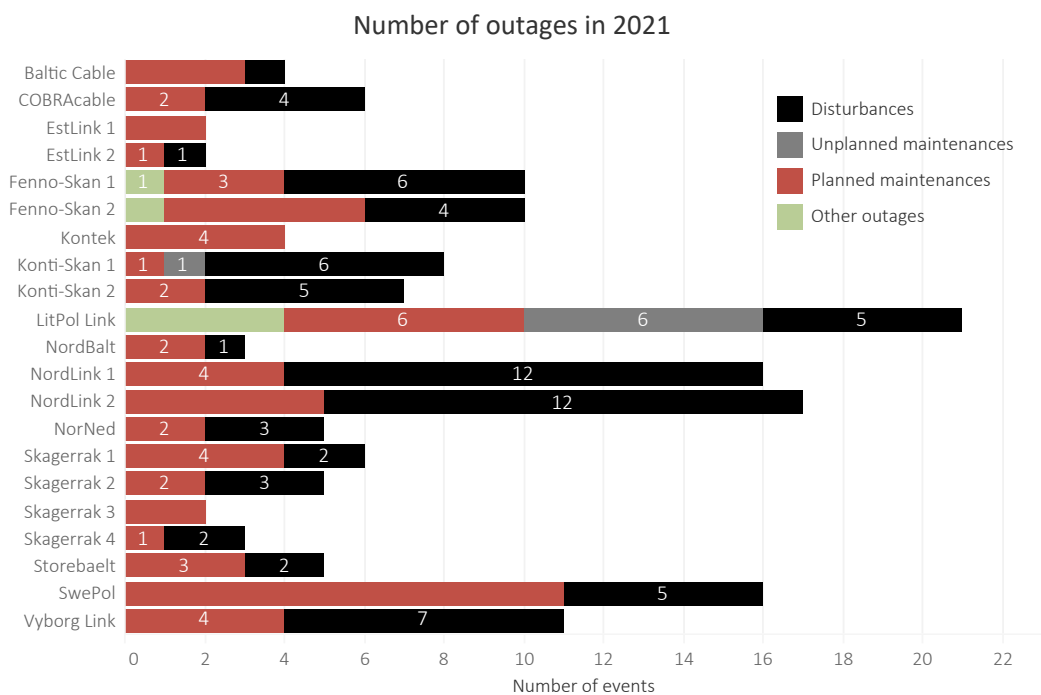

Figure 5.4: The number of disturbance outages, unplanned maintenance and planned maintenance outages and other outages for each link in 2021.

## 5.2 Overview of years 2012–2021

Figure 5.5 presents the annual utilisation (%) of all HVDC links and Figure 5.6 presents the annual utilisation with all utilisation categories.

The percentage of unavailable technical capacity ( $E_U$ ) in 2021 dropped to the same levels as in 2017 (9 %), while the percentage of transmission ( $E_T$ ) was high compared to previous years. Many of the HVDC links that have had a high share of unavailable capacity performed well in 2021, which is a good sign for the future.

The higher availability did not have a high impact on the utilisation rate, which increased from 61.6 % in 2020 to 62.3 % in 2021. On the other hand, the recently commissioned HVDC links have increased the total technical capacity ( $E_{max}$ ) available to the markets, as can be seen in

Figure 5.6. Compared to 2020 when 58.8 TWh of electricity was transmitted through the HVDC links, 8.1 TWh or almost 14 % more was transmitted in 2021. The amount of transmitted capacity has increased by almost 70 % since 2012–2014 when around 40 TWh was transmitted annually.

Figure 5.7 presents the annual utilisation rate grouped by utilisation percentage for all HVDC links. Figure 5.8 presents the annual unavailable technical capacity (%) by unavailability category. Figure 5.9 presents the annual unavailability hours (%) of the HVDC links.

Annual utilisation ( $E_T$ ), unavailability ( $E_U$ ) and technical capacity not used ( $E_{TCNU}$ ) percentages are presented in Table 5.1, Table 5.2 and Table 5.3, respectively.

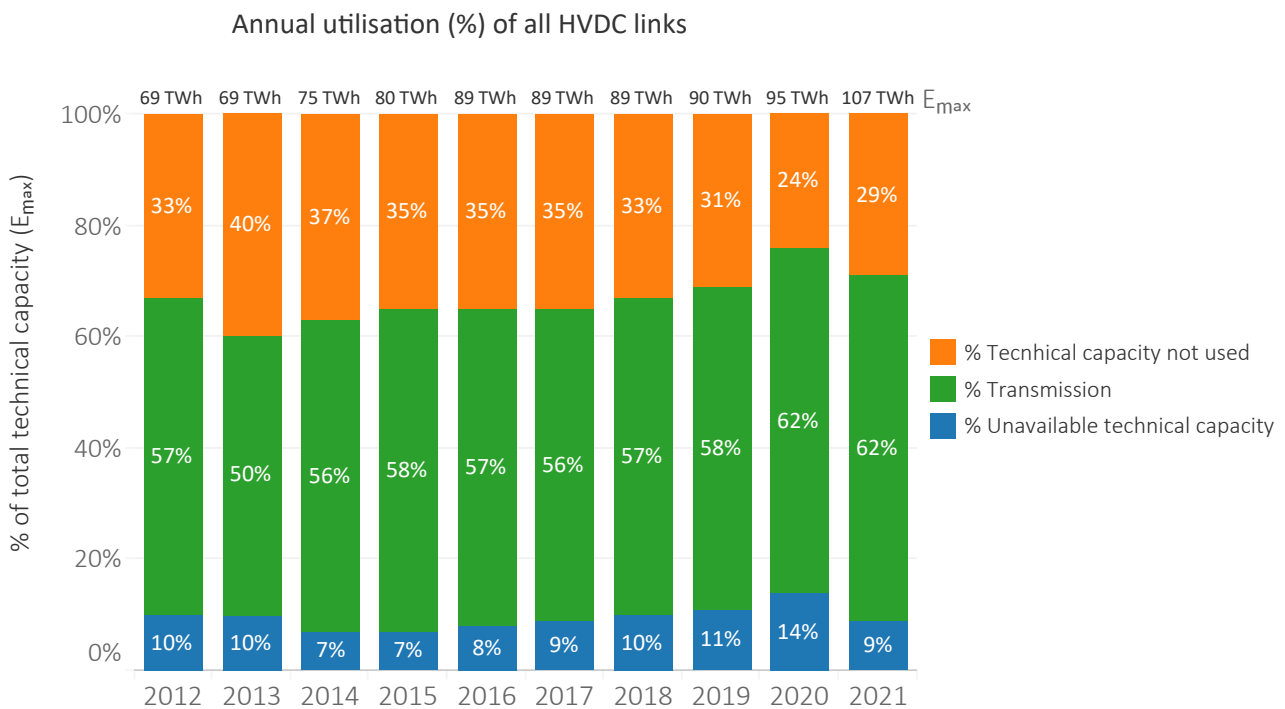

Figure 5.5: The annual utilisation percentage of all HVDC links since 2012. The unavailable technical capacity ( $E_U$ ) is the amount of technical capacity ( $E_{max}$ ) not available due to limitations or outages. Transmission ( $E_T$ ) is the amount of technical capacity ( $E_{max}$ ) transmitted through the HVDC links. Technical capacity not used ( $E_{TCNU}$ ) is the residual energy that has neither been transmitted nor been unavailable due to limitations or outages. More detailed explanations can be read in Chapter 3.

Annual utilisation of all HVDC links

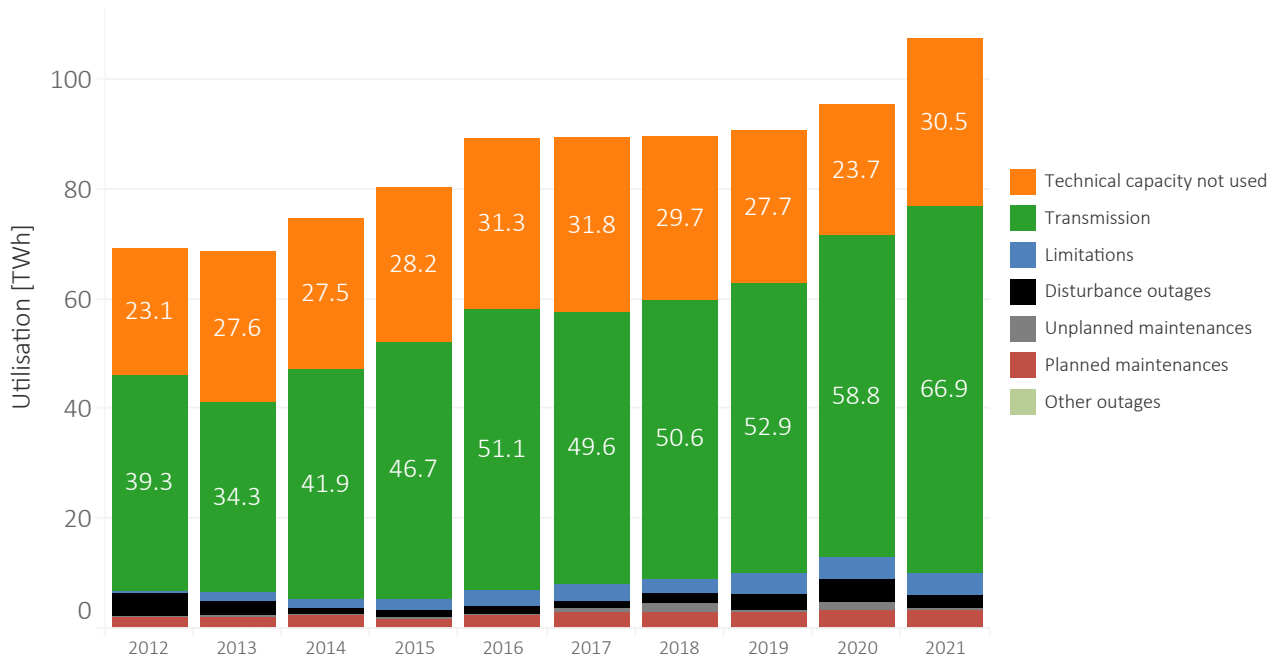

Figure 5.6: Annual utilisation (MWh) of all HVDC links. Transmission ( $E_T$ ) is the amount of technical capacity ( $E_{max}$ ) transmitted through the HVDC links. Limitations, disturbance outages, unplanned and planned maintenance outages and other outages form together the unavailable technical capacity ( $E_U$ ). Technical capacity not used ( $E_{TCNU}$ ) is the residual energy that has neither been transmitted nor been unavailable due to limitations or outages. The categories are explained in more detail in Chapter 3. The larger capacity increases in some years is due to new links being introduced to the report. The maximum technical capacity ( $E_{max}$ ) is marginally higher on leap years due to one extra day of operation.

Annual utilisation rates grouped by utilisation percentage, all HVDC links

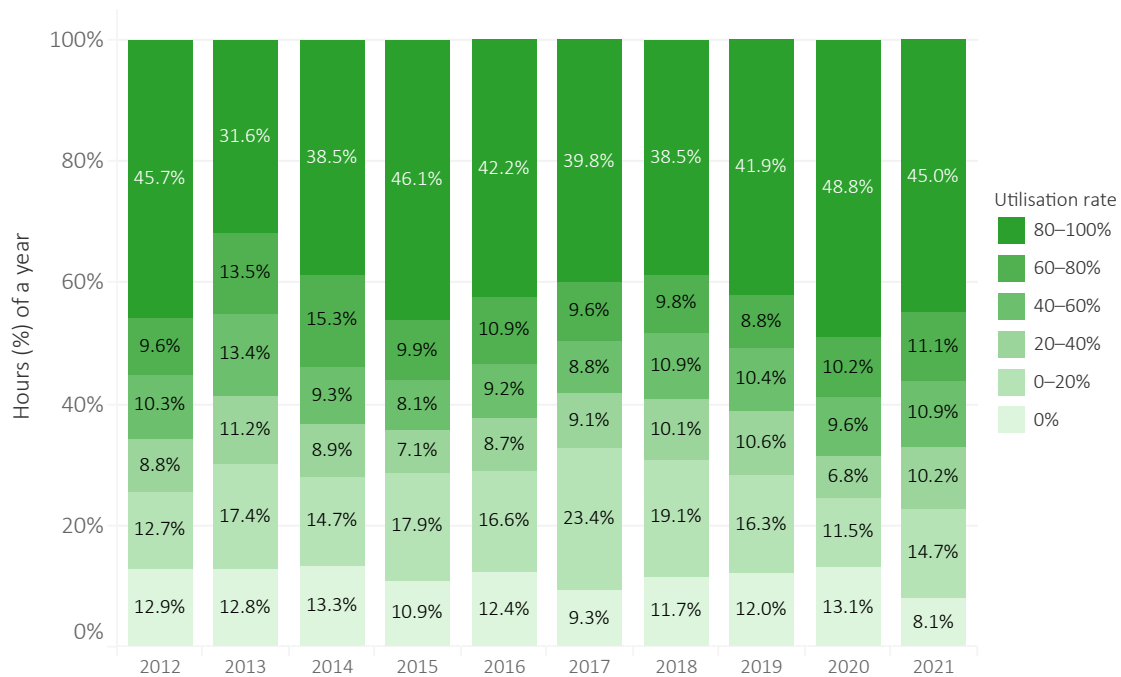

Figure 5.7: Annual utilisation rate grouped by utilisation percentage for all HVDC links. The HVDC links were utilised by more than 80 % of their respective maximum technical capacity 45 % of the time in 2020.

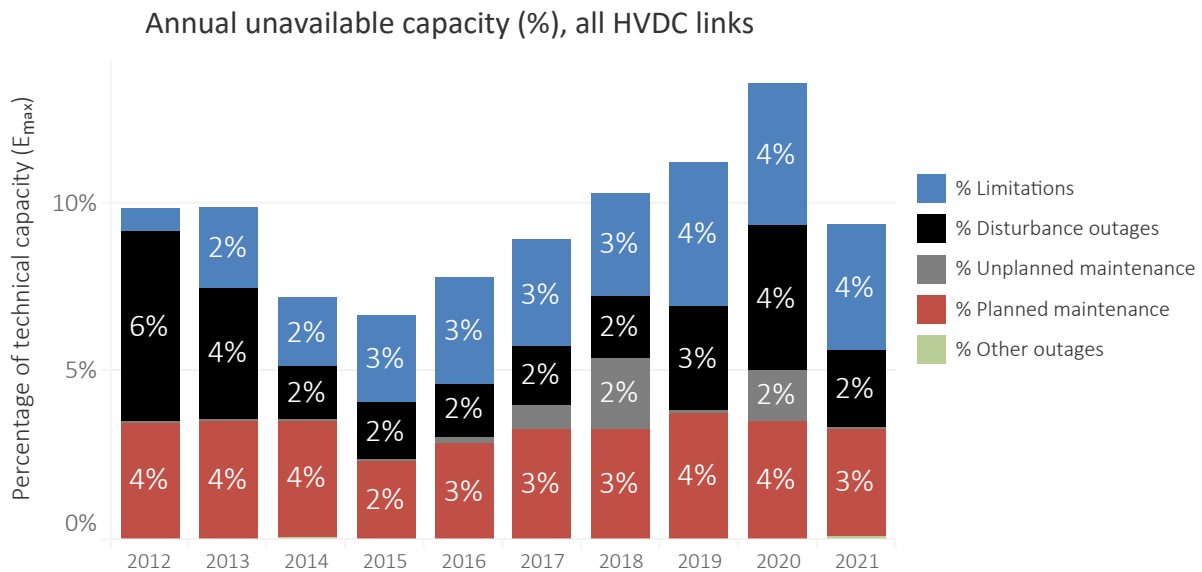

Figure 5.8: Unavailable technical capacity (%) by unavailability category for all HVDC links combined. The unavailability categories are limitations, disturbance outages, unplanned and planned maintenances and other outages.

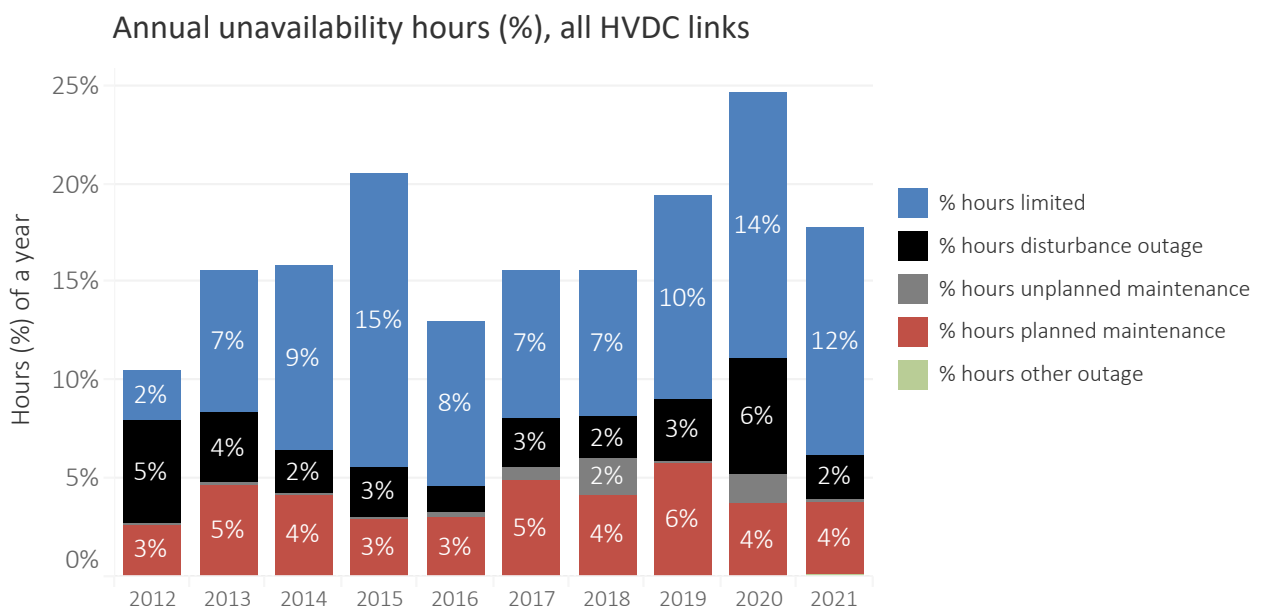

Figure 5.9: Annual unavailability hours (%) by unavailability category. The categories are limitation, unplanned or planned maintenance or a disturbance or other outage. The percentage is calculated by counting the number of hours with a limitation or outage and dividing it by the total number of hours in a year. It should be noted that any single hour can be affected by both an outage and a limitation. A higher value in the percentage of hours may indicate that the corresponding type of event has not fully disconnected the affected HVDC link from the system. A lower value may instead indicate that the corresponding event type has affected an HVDC link with a high rated capacity.

Table 5.1: Annual utilisation (%) of HVDC links per market connection.

	2012	2013	2014	2015	2016	2017	2018	2019	2020	2021
DK1-NL								79.7%	50.6%	63.0%
DK2-DE	70.0%	70.1%	73.2%	74.8%	66.8%	66.3%	53.3%	68.6%	47.4%	71.4%
DK2-DK1	44.9%	54.4%	58.3%	70.1%	78.0%	63.7%	63.4%	58.3%	70.7%	57.2%
FI-EE	58.6%	54.9%	40.7%	56.8%	42.3%	29.2%	37.0%	46.6%	75.3%	76.9%
FI-SE3	53.8%	52.5%	76.2%	75.8%	77.7%	70.2%	71.8%	81.2%	84.6%	68.0%
LT-PL					33.5%	46.7%	53.5%	61.5%	58.4%	54.8%
NO2-DE										44.0%
NO2-DK1	67.5%	60.7%	54.5%	54.0%	60.6%	54.1%	52.7%	46.2%	62.3%	67.0%
NO2-NL	89.4%	71.6%	90.5%	93.9%	72.5%	82.8%	68.3%	61.3%	76.7%	62.7%
RU-FI	33.8%	35.6%	25.4%	29.1%	45.8%	49.8%	66.7%	61.5%	23.1%	71.7%
SE3-DK1	55.9%	40.5%	49.3%	48.7%	58.8%	51.8%	52.7%	50.1%	57.3%	49.0%
SE4-DE	59.5%	32.1%	47.5%	30.5%	43.3%	45.6%	33.2%	36.0%	54.9%	47.9%
SE4-LT					43.6%	51.5%	50.5%	62.9%	76.2%	60.4%
SE4-PL	52.3%	33.9%	60.9%	67.2%	55.8%	62.3%	66.1%	62.1%	72.1%	69.3%
Grand Total	56.8%	49.9%	56.1%	58.2%	57.2%	55.5%	56.5%	58.3%	61.6%	62.3%

Table 5.2: Annual unavailability (%) of HVDC links per market connection.

	2012	2013	2014	2015	2016	2017	2018	2019	2020	2021
DK1-NL								5.1%	29.3%	9.9%
DK2-DE	5.8%	3.9%	3.5%	5.2%	10.4%	14.3%	25.9%	3.8%	30.0%	5.0%
DK2-DK1	2.9%	9.9%	4.6%	2.4%	2.8%	1.6%	2.2%	2.5%	0.3%	1.4%
FI-EE	2.6%	5.0%	14.7%	5.8%	3.6%	0.6%	3.6%	2.2%	2.7%	1.5%
FI-SE3	27.3%	17.2%	5.4%	9.5%	1.5%	1.2%	1.1%	4.7%	0.9%	13.1%
LT-PL					14.0%	10.1%	6.1%	3.6%	8.6%	13.4%
NO2-DE										9.8%
NO2-DK1	2.4%	7.9%	10.5%	6.5%	4.8%	18.0%	12.7%	27.0%	23.6%	8.2%
NO2-NL	3.4%	19.3%	4.5%	4.2%	8.1%	8.4%	13.8%	13.5%	16.9%	27.1%
RU-FI	9.8%	1.3%	0.4%	0.0%	1.5%	2.3%	5.2%	5.4%	11.5%	8.1%
SE3-DK1	4.7%	10.7%	16.1%	16.7%	5.5%	6.7%	4.3%	15.8%	16.7%	10.7%
SE4-DE	22.1%	18.1%	6.6%	12.5%	20.4%	27.1%	36.3%	26.2%	18.7%	9.8%
SE4-LT					25.7%	16.5%	22.0%	7.6%	5.5%	5.8%
SE4-PL	0.2%	3.3%	7.1%	7.3%	15.3%	5.9%	4.2%	14.0%	12.8%	8.9%
Grand Total	9.8%	9.9%	7.2%	6.7%	7.8%	8.9%	10.3%	11.2%	13.5%	9.3%

Table 5.3: Annual technical capacity not used (%) of HVDC links per market connection.

	2012	2013	2014	2015	2016	2017	2018	2019	2020	2021
DK1-NL								15.2%	20.1%	27.1%
DK2-DE	24.3%	26.1%	23.3%	20.1%	22.8%	19.4%	20.7%	27.7%	22.6%	23.6%
DK2-DK1	52.1%	35.6%	37.1%	27.5%	19.3%	34.7%	34.5%	39.2%	29.1%	41.3%
FI-EE	38.8%	40.0%	44.7%	37.3%	54.1%	70.2%	59.3%	51.2%	22.0%	21.6%
FI-SE3	18.9%	30.3%	18.4%	14.8%	20.7%	28.6%	27.1%	14.1%	14.6%	18.8%
LT-PL					52.5%	43.2%	40.3%	34.9%	33.0%	31.8%
NO2-DE										46.2%
NO2-DK1	30.1%	31.4%	34.9%	39.5%	34.6%	27.9%	34.6%	26.8%	14.2%	24.7%
NO2-NL	7.2%	9.1%	5.0%	1.9%	19.4%	8.8%	17.9%	25.2%	6.4%	10.2%
RU-FI	56.5%	63.1%	74.2%	70.9%	52.7%	47.9%	28.2%	33.1%	65.3%	20.3%
SE3-DK1	39.3%	48.8%	34.6%	34.6%	35.8%	41.4%	43.0%	34.1%	26.0%	40.2%
SE4-DE	18.4%	49.8%	45.9%	57.0%	36.3%	27.4%	30.6%	37.8%	26.4%	42.3%
SE4-LT					30.7%	32.1%	27.6%	29.4%	18.3%	33.8%
SE4-PL	47.5%	62.8%	32.0%	25.5%	28.9%	31.8%	29.7%	23.9%	15.1%	21.8%
Grand Total	33.4%	40.2%	36.8%	35.1%	35.0%	35.5%	33.2%	30.5%	24.9%	28.4%

### 5.3 Individual presentations of each HVDC link

This section presents the performance of each HVDC link. Figure 5.10 presents the geographical location of each HVDC link. The categories used in the following presentations of each separate HVDC link are presented and defined in Chapter 3.

Note that the sums in the tables for each link may show a

technical capacity  $E_{max}$  higher than the  $E_{max}$  stated in the diagram. This is due to power flows that may momentarily be higher than rated technical capacity of the links. Other times, when power flow is below the rated technical capacity (and there is no limitation reported), the difference is registered in the category “technical capacity not used”.

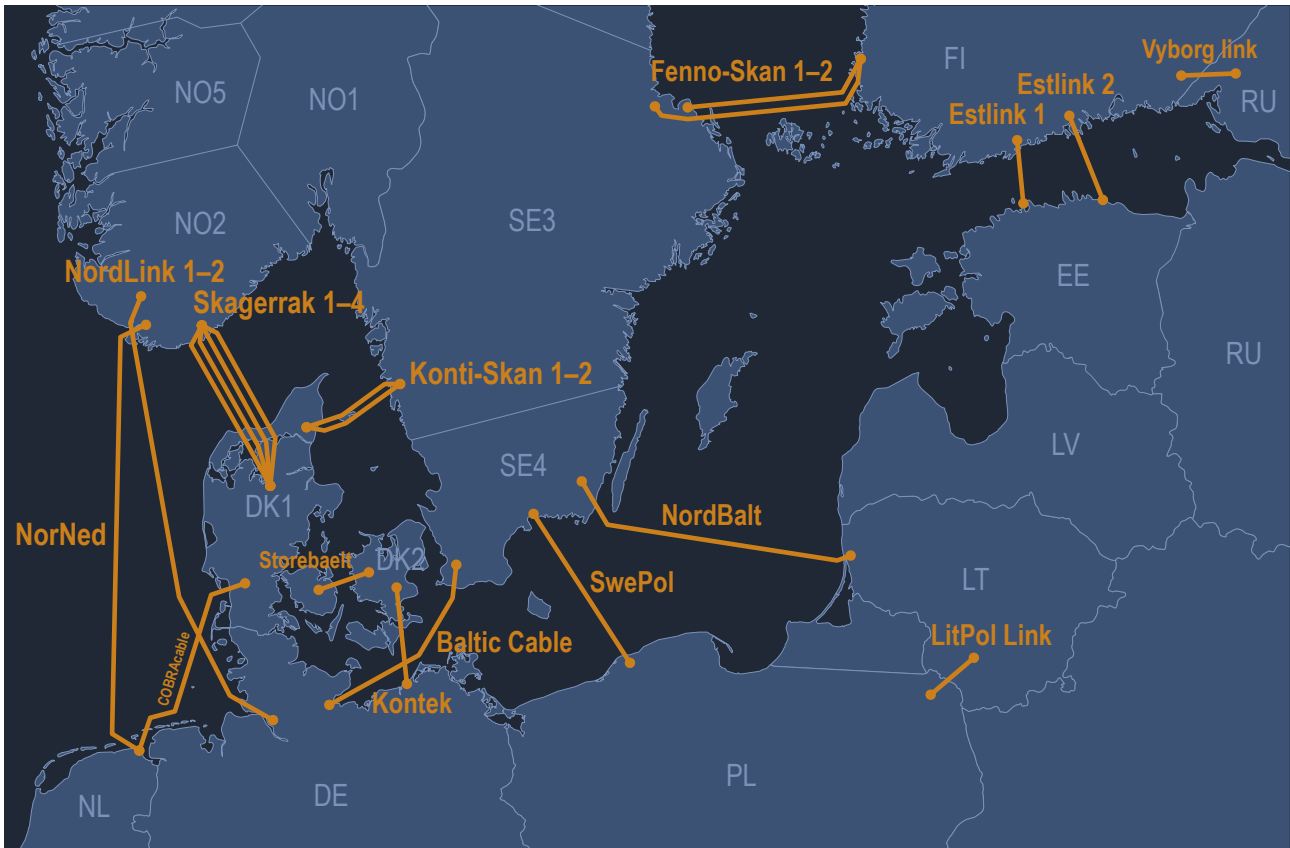

Figure 5.10: A map of the bidding zones and the 19 HVDC links included in this report.

### 5.3.1 Baltic Cable

Figure 5.11 presents the availability and utilisation of Baltic Cable for 2021 and Table 5.4 presents the numerical values behind it. Baltic Cable is connected between southern Sweden (bidding zone SE4) and Germany (bidding zone DE-TenneT). The operations started in 1994 and the transmission capacity is 600 MW.

In 2021, Baltic Cable had an available technical capacity of 90 %. The technical capacity not used was 42 %. Totally,

2.2 TWh (43 % of the technical capacity) was transmitted south (SE4→DE-TenneT) and 0.3 TWh (5 % of the technical capacity) was transmitted north (DE-TenneT→SE4).

The annual maintenance of Baltic Cable lasted 4 days in late August. Except for two short planned corrective maintenances and one short disturbance outage, there were no other outages on Baltic Cable in 2021.

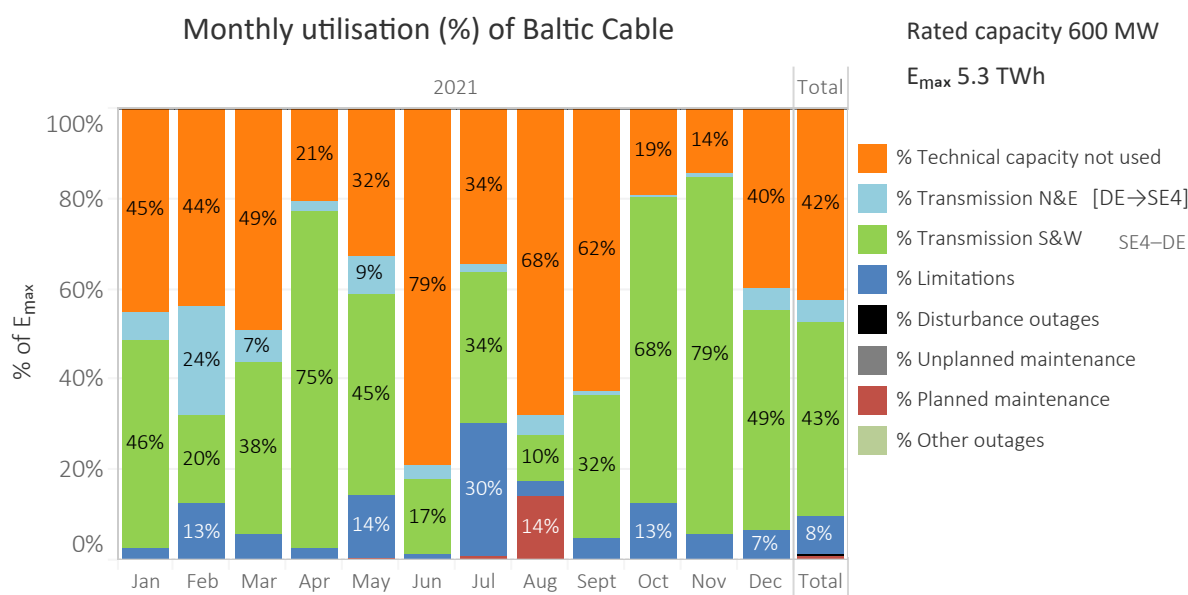

Figure 5.11: Monthly percentage allocation of utilisation by category for Baltic Cable in 2021. The availability and utilisation categories are defined in detail in Chapter 3.

Table 5.4: Monthly allocation of technical capacity (E<sub>max</sub>) for The Baltic Cable in 2021. Note that losses are not included in the technical capacity (E<sub>max</sub>), as is shown in Figure 3.1.

	Jan	Feb	Mar	Apr	May	Jun	Jul	Aug	Sept	Oct	Nov	Dec	Total	% total
Technical capacity not used, GWh	201.6	176.5	219.9	89.0	145.1	341.0	153.7	303.7	269.5	85.7	61.6	176.7	2224.0	42.3%
Transmission N&E, GWh	28.9	96.7	31.6	9.2	38.5	13.2	7.1	18.3	4.2	1.1	4.4	23.4	276.8	5.3%
Transmission S&W, GWh	203.9	79.1	169.8	323.9	200.2	72.8	149.6	46.2	137.6	303.1	341.9	217.0	2245.1	42.7%
Limitations, GWh	12.8	51.3	25.6	11.3	61.2	5.1	132.5	14.7	20.7	56.6	23.5	29.3	444.6	8.5%
Disturbance outages, GWh	-	-	-	-	-	-	-	-	-	-	0.6	-	0.6	0.0%
Unplanned maintenance., GWh	-	-	-	-	-	-	-	-	-	-	-	-	-	-
Planned maintenance, GWh	-	-	-	-	2.1	-	3.5	63.6	-	-	-	-	69.1	1.3%
Other outages, GWh	-	-	-	-	-	-	-	-	-	-	-	-	-	-
Total, GWh	447.2	403.6	447.0	433.4	447.1	432.2	446.4	446.4	432.0	446.5	432.1	446.4	5260.3	100.0%
Losses SW, GWh	7.2	3.5	6.0	8.1	5.8	6.0	4.1	4.1	6.7	8.0	8.7	7.3	75.5	1.4%
Losses NE, GWh	0.7	2.0	0.7	0.2	0.8	0.3	0.1	0.4	0.1	-	0.1	0.4	5.8	0.1%



Figure 5.12 presents the annual utilisation of Baltic Cable per utilisation and unavailability category for the years 2012–2021.

turbance outage, an unplanned or planned maintenance outage or other outage annually during the years 2012–2021. Figure 5.14 presents the annual number of disturbance outages, unplanned and planned maintenances and other outages during the years 2012–2021.

Figure 5.13 presents the percentage of hours of a year Baltic Cable has been affected by either a limitation, a dis-

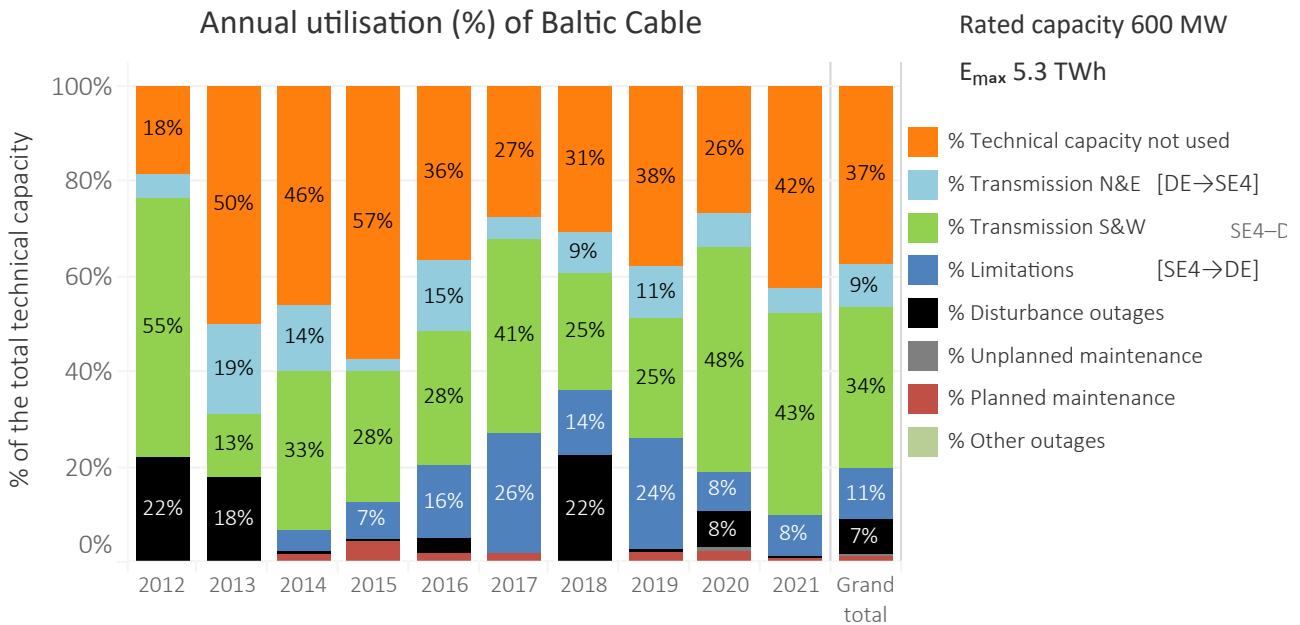

Figure 5.12: Annual utilisation of Baltic Cable per the utilisation and unavailability categories for the years 2012–2021. The utilisation and unavailability categories are described in more detail in Chapter 3.

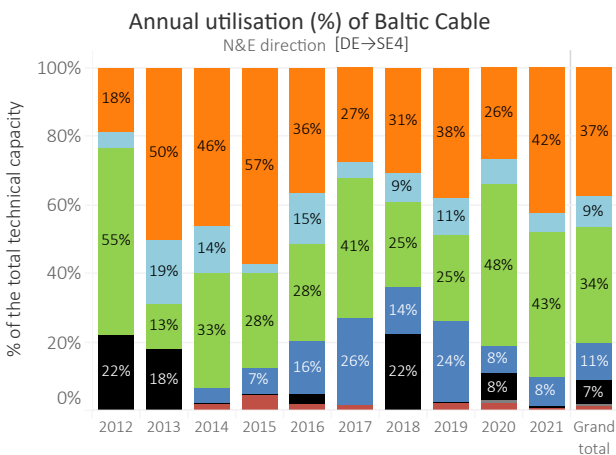

Figure 5.13: Percentage of hours Baltic Cable has been affected by either a limitation or an outage annually since 2012. The percentage is calculated by counting the number of hours with a limitation or outage and dividing it by the total number of hours in a year. It should be noted that any single hour can be affected by both an outage and a limitation.

Percentage of unavailable hours annually per category for Baltic Cable

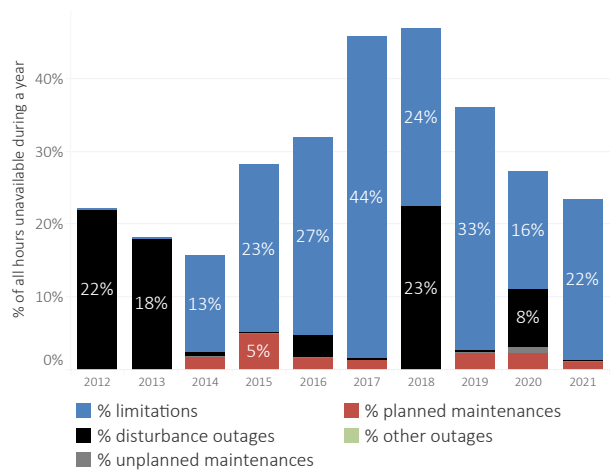

Figure 5.14: The annual number of disturbances, unplanned and planned maintenance outages and other outages for Baltic Cable for the years 2012–2021. Baltic cable has not had any other outages during the years 2012–2021.

### 5.3.2 COBRACable

Figure 5.15 presents the availability and utilisation of COBRACable for 2021 and Table 5.5 presents the numerical values behind it. COBRACable has been in operation since 2019. In Denmark (bidding zone DK1) it is connected to Endrup substation and in Netherlands to Eemshaven (bidding zone APX NL). COBRACable was commissioned 5 November and has a transmission capacity of 700 MW.

In 2021, COBRACable had an available technical capacity of 90 %. The technical capacity not used was 27 %. Totally, 3.0 TWh (49 % of the technical capacity) was transmit-

ted south to the Netherlands (DK1→APX NL) and 0.9 TWh (14 % of the technical capacity) was transmitted north to Denmark (APX NL→DK1).

COBRACable had two maintenance outages in 2021. One was coverage of exposed offshore cable, and the other was annual maintenance. There were five disturbance outages: one was continuation of the cable fault from 2020, two of them came from a failed CPU card in MMS, and the last two were due to work in neighbouring substation which accidentally tripped COBRACable.

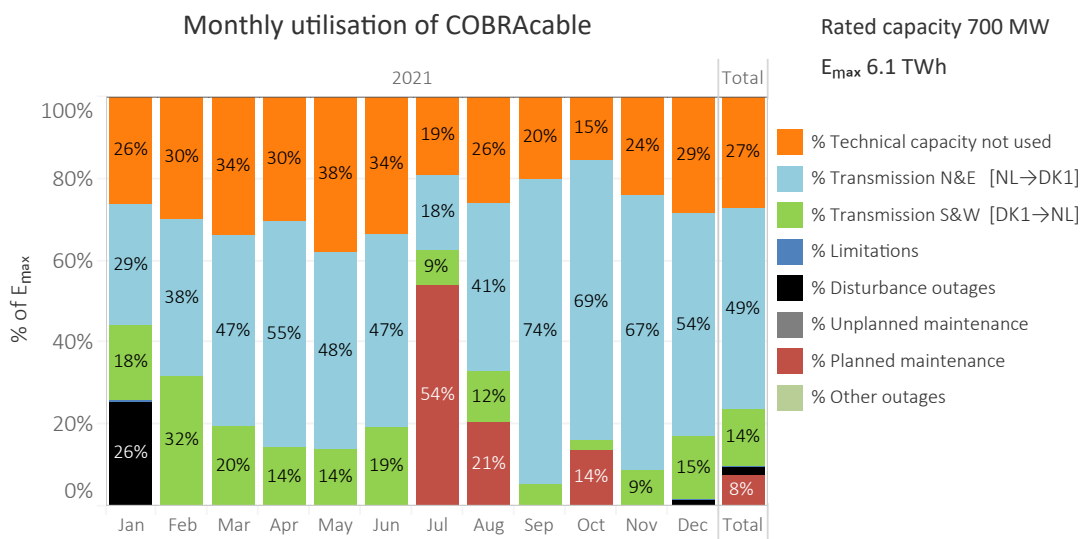

Figure 5.15: Monthly percentage allocation of utilisation by category for COBRACable in 2021. The availability and utilisation categories are defined in detail in Chapter 3.

Table 5.5: Monthly allocation of technical capacity (E<sub>max</sub>) for COBRACable in 2021. Note that losses are not included in the technical capacity (E<sub>max</sub>), as is shown in Figure 3.1.

Monthly utilisation of COBRACable (South & West direction DK1→NL)	2021												Total	% total
	Jan	Feb	Mar	Apr	May	Jun	Jul	Aug	Sep	Oct	Nov	Dec		
Technical capacity not used, GWh	136.5	141.3	176.2	153.6	198.3	169.1	99.5	135.0	101.9	80.3	122.4	149.5	1663.6	27.1%
Transmission N&E, GWh	153.5	180.2	242.7	278.6	251.2	239.2	95.6	213.0	374.8	357.4	335.8	283.4	3005.5	49.0%
Transmission S&W, GWh	95.0	148.9	101.9	71.8	71.3	95.1	45.1	64.9	27.2	11.1	45.0	78.5	855.7	14.0%
Limitations, GWh	2.3	-	-	-	-	-	-	-	-	-	0.8	3.4	6.5	0.1%
Disturbance outages, GWh	133.6	-	-	-	-	0.6	-	-	-	-	-	6.0	140.2	2.3%
Unplanned maintenance, GWh	-	-	-	-	-	-	-	-	-	-	-	-	-	-
Planned maintenance, GWh	-	-	-	-	-	-	280.5	108.0	-	71.9	-	-	460.4	7.5%
Other outages, GWh	-	-	-	-	-	-	-	-	-	-	-	-	-	-
Total, GWh	520.8	470.4	520.8	504.0	520.8	504.0	520.8	520.8	504.0	520.8	504.0	520.8	6132.0	100.0%
Losses SW, GWh	2.1	3.4	2.3	1.6	1.7	2.2	0.9	1.5	0.7	0.3	1.0	1.8	19.4	0.3%
Losses NE, GWh	4.1	5.2	7.0	7.9	7.2	6.7	2.7	6.0	10.8	10.5	9.7	7.8	85.6	1.4%

Figure 5.16 presents the annual utilisation of COBRACable per utilisation and unavailability category for the years 2019–2021.

Figure 5.17 presents the percentage of hours of a year COBRACable has been affected by either a limitation, a disturbance outage, an unplanned or planned maintenance

outage or other outage annually during the years 2019–2021. Figure 5.18 presents the annual number of disturbance outages, unplanned and planned maintenances and other outages during the years 2019–2021.

Data for 2019 does not cover the whole year because COBRACable was commissioned in September 2019.

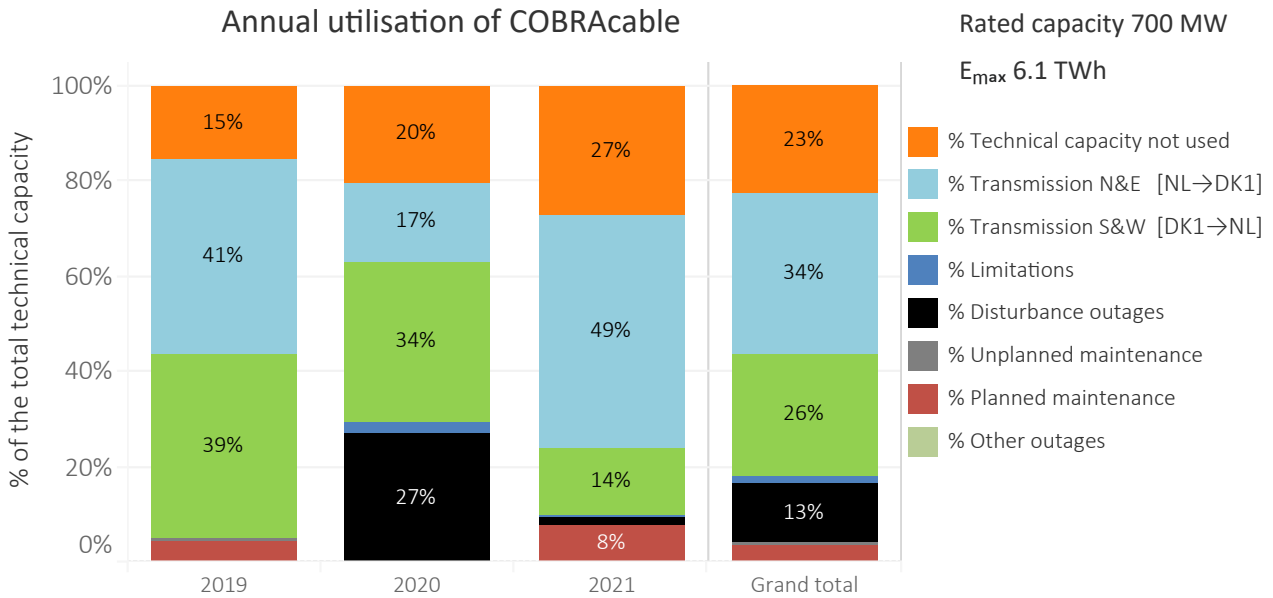

Figure 5.16: Annual utilisation of COBRACable per the utilisation and unavailability categories for the years 2019–2021. The utilisation and unavailability categories are described in more detail in Chapter 3.

Percentage of unavailable hours annually per category for COBRACable

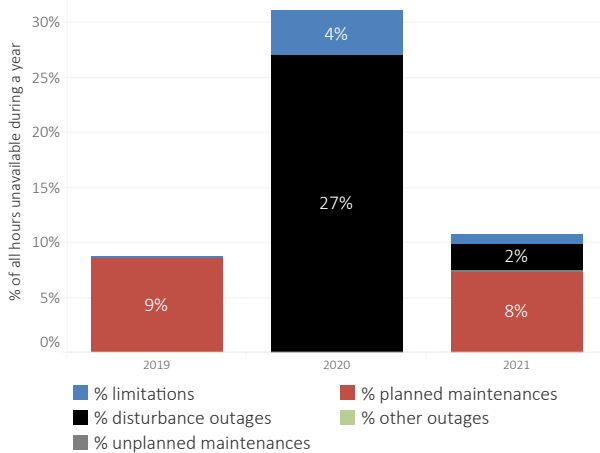

Figure 5.17: Percentage of hours COBRACable has been affected by either a limitation or an outage annually since 2019. The percentage is calculated by counting the number of hours with a limitation or outage and dividing it by the total number of hours in a year. It should be noted that any single hour can be affected by both an outage and a limitation.

Number of outages annually for COBRACable

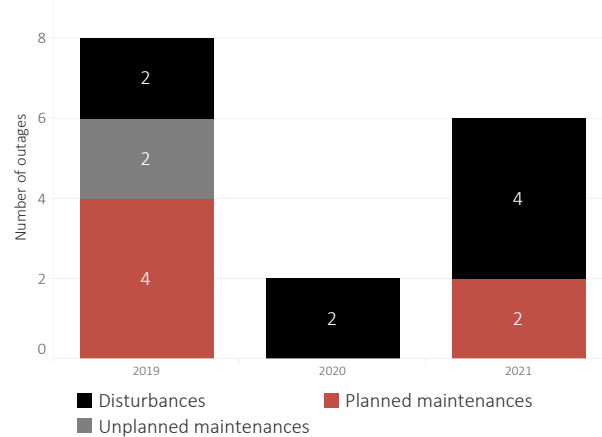

Figure 5.18: The annual number of disturbances, unplanned and planned maintenance outages and other outages for COBRACable for the years 2019–2021.

### 5.3.3 EstLink 1

Figure 5.19 presents the availability and utilisation of EstLink 1 for 2021 and Table 5.6 presents the numerical values behind it. EstLink 1 has been in operation since 2006 and is the first HVDC connection between Finland and Estonia. In Finland, it is connected to Espoo substation (bidding zone FI) and in Estonia, it is connected to Harku substation (bidding zone EE). The transmission capacity of EstLink 1 is 350 MW.

In 2021, EstLink 1 had an available technical capacity of 97 %. The technical capacity not used was 39 % because EstLink 2 is prioritised due to its lower transmission losses

and because EstLink 1 is often used in Automatic Frequency Control Mode. Totally, 1.8 TWh (57 % of the technical capacity) was transmitted south (FI→EE) and less than 0.1 TWh (0.5 % of the technical capacity) was transmitted north (EE→FI).

The annual maintenance of EstLink 1 lasted 5 days in June. Additionally, there was one 3-day planned maintenance outage for cable work and corrective maintenance of phase reactors on the Finnish side. Last, EstLink 1 had no disturbance outages in 2021.

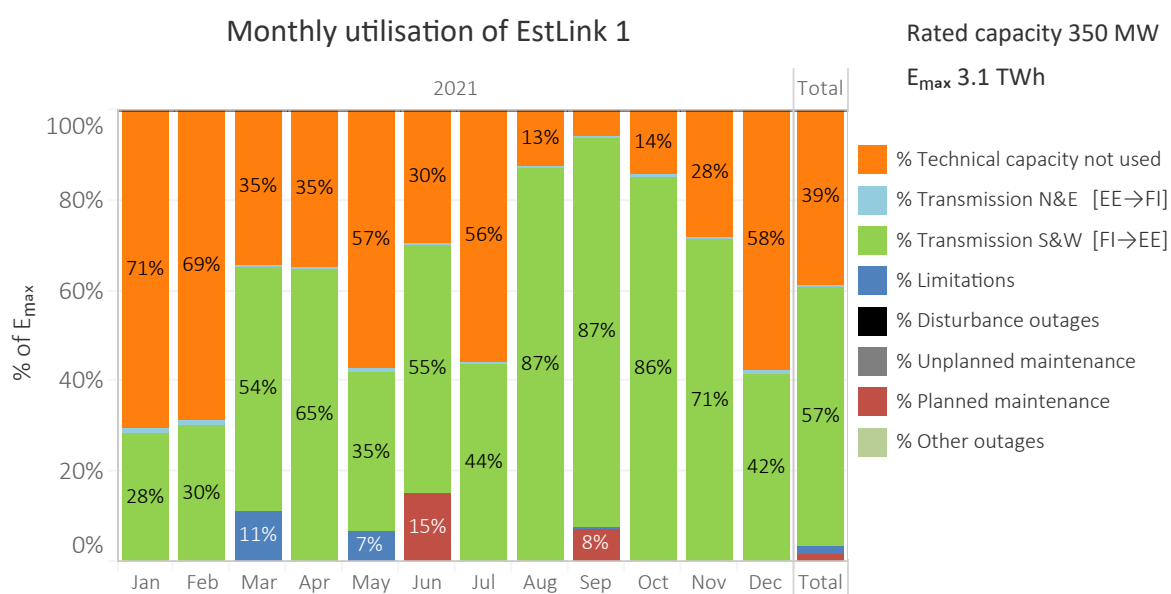

Figure 5.19: Monthly percentage allocation of utilisation by category for EstLink 1 in 2021. The availability and utilisation categories are defined in detail in Chapter 3.

Table 5.6: Monthly allocation of technical capacity ( $E_{max}$ ) for EstLink 1 in 2021. Note that losses are not included in the technical capacity ( $E_{max}$ ), as is shown in Figure 3.1.

Monthly utilisation of EstLink 1 (South & West direction FI→EE)																
	Jan	Feb	Mar	Apr	May	Jun	Jul	Aug	Sep	Oct	Nov	Dec	Total	% total		
Technical capacity not used, GWh	184.5	162.1	90.5	88.9	148.8	74.9	145.7	33.0	14.4	37.0	71.7	150.6	1202.1	39.0%		
Transmission N&E, GWh	2.6	2.4	1.2	0.7	2.5	0.8	1.3	0.2	-	0.2	0.7	1.7	14.4	0.5%		
Transmission S&W, GWh	74.1	71.3	141.4	164.2	92.6	139.3	114.1	229.2	220.3	225.5	181.7	108.9	1762.7	57.2%		
Limitations, GWh	-	-	28.9	-	17.0	-	-	-	0.2	-	-	-	46.1	1.5%		
Disturbance outages, GWh	-	-	-	-	-	-	-	-	-	-	-	-	-	-		
Unplanned maintenance., GWh	-	-	-	-	-	-	-	-	-	-	-	-	-	-		
Planned maintenance, GWh	-	-	-	-	-	38.2	-	-	19.4	-	-	-	57.6	1.9%		
Other outages, GWh	-	-	-	-	-	-	-	-	-	-	-	-	-	-		
<b>Total, GWh</b>	<b>261.1</b>	<b>235.8</b>	<b>262.0</b>	<b>253.8</b>	<b>260.9</b>	<b>253.2</b>	<b>261.1</b>	<b>262.5</b>	<b>254.4</b>	<b>262.7</b>	<b>254.2</b>	<b>261.2</b>	<b>3082.8</b>	<b>100.0%</b>		
Losses SW, GWh	-	-	-	-	-	-	-	-	-	-	-	-	-	-		
Losses NE, GWh	-	-	-	-	-	-	-	-	-	-	-	-	-	-		

Figure 5.20 presents the annual utilisation of EstLink 1 per utilisation and unavailability category for the years 2012–2021.

Figure 5.21 presents the percentage of hours of a year EstLink 1 has been affected by either a limitation, a disturbance outage, an unplanned or planned maintenance

outage or other outage annually during the years 2012–2021. Figure 5.22 presents the annual number of disturbance outages, unplanned and planned maintenances and other outages during the years 2012–2021.

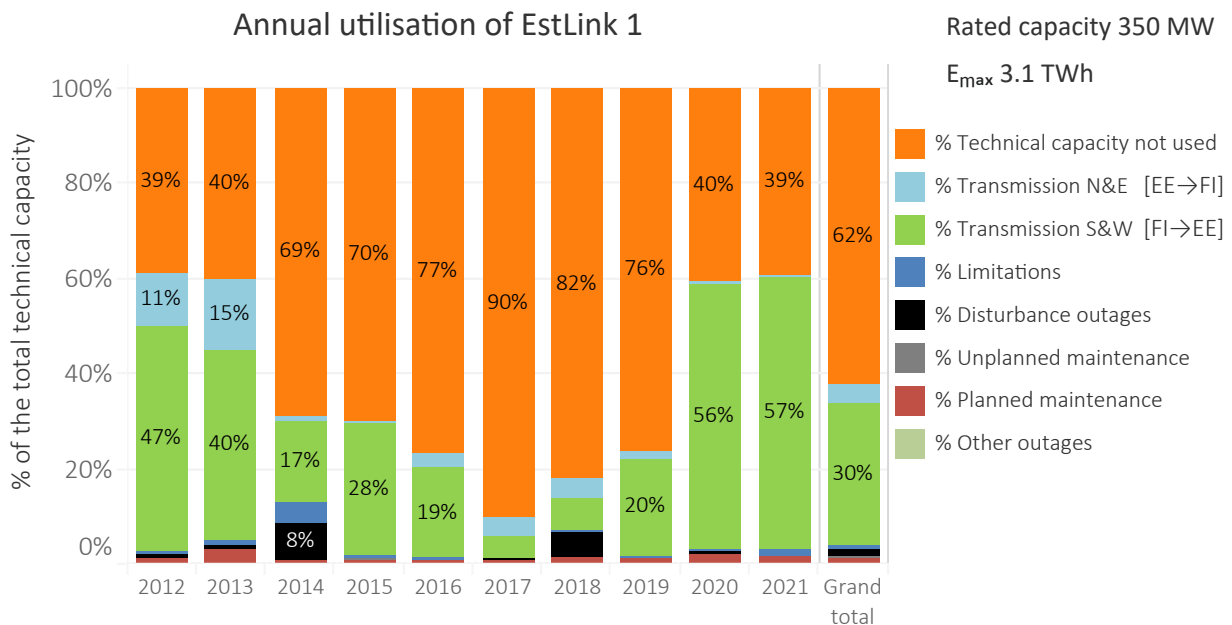

Figure 5.20: Annual utilisation of EstLink 1 per the utilisation and unavailability categories for the years 2012–2021. The utilisation and unavailability categories are described in more detail in Chapter 3.

Percentage of unavailable hours annually per category for EstLink 1

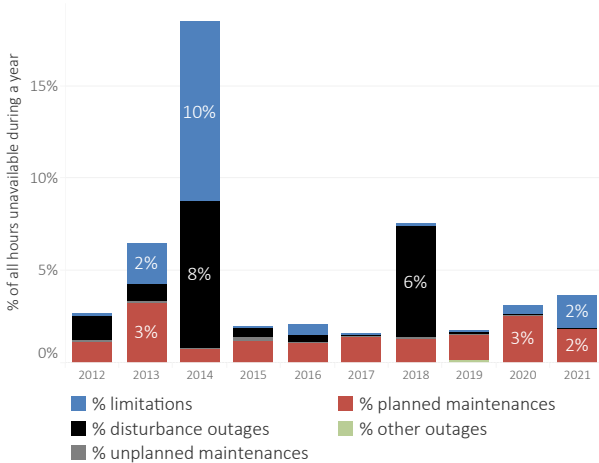

Figure 5.21: Percentage of hours EstLink 1 has been affected by either a limitation or an outage annually since 2012. The percentage is calculated by counting the number of hours with a limitation or outage and dividing it by the total number of hours in a year. It should be noted that any single hour can be affected by both an outage and a limitation.

Number of outages annually for EstLink 1

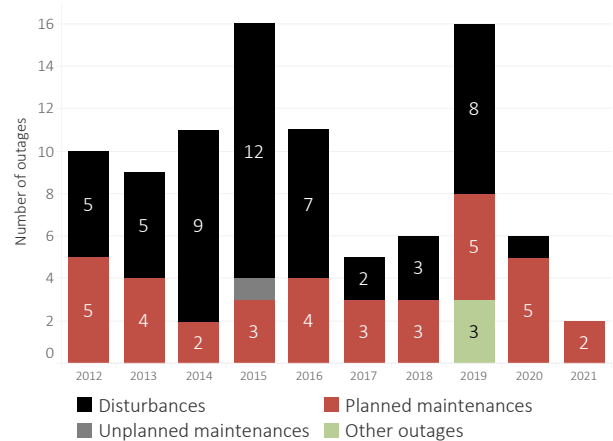

Figure 5.22: The annual number of disturbances, unplanned and planned maintenance outages and other outages for EstLink 1 for the years 2012–2021.

### 5.3.4 EstLink 2

Figure 5.23 presents the availability and utilisation of EstLink 2 for 2021 and Table 5.7 presents the numerical values behind it. EstLink 2 was commissioned in February 2014 and is the second HVDC connection between Finland and Estonia. In Finland, it is connected to Anttila substation (bidding zone FI) and in Estonia, it is connected to Püssi substation (bidding zone EE). The transmission capacity of EstLink 2 is 650 MW.

In 2021, EstLink 2 had an available technical capacity of 99.6 %. The technical capacity not used was 12 %. Totally, 4.9 TWh (86 % of the technical capacity) was transmitted

south (FI→EE) and less than 0.1 TWh (0.9 % of the technical capacity) was transmitted north (EE→FI).

No annual maintenance for EstLink 2 was held in 2021 as it is done every second year. There was one short maintenance outage for cable oil sampling and signal testing. The power was reduced 10–30MW for several months from June to mid-October due to sea cable temperature rise near the Finnish coast. One short power reduction occurred due too filter trip and another due to external AC network in Estonia. Additionally, there was one short disturbance due to human actions.

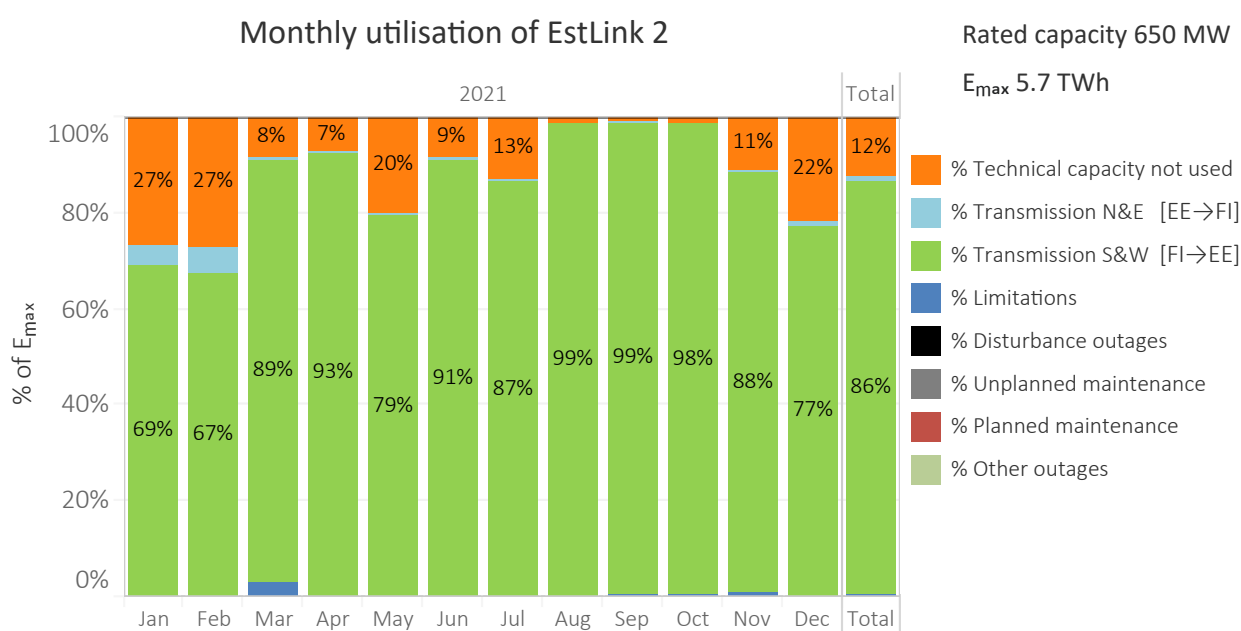

Figure 5.23: Monthly percentage allocation of utilisation by category for EstLink 2 in 2021. The availability and utilisation categories are defined in detail in Chapter 3.

Table 5.7: Monthly allocation of technical capacity ( $E_{max}$ ) for EstLink 2 in 2021. Note that losses are not included in the technical capacity ( $E_{max}$ ), as is shown in Figure 3.1.

	Jan	Feb	Mar	Apr	May	Jun	Jul	Aug	Sep	Oct	Nov	Dec	Total	% total
Technical capacity not used, GWh	130.5	119.4	40.5	34.0	98.7	41.0	63.7	6.7	4.3	6.2	51.5	107.4	703.9	12.3%
Transmission N&E, GWh	20.1	23.4	0.9	-	1.2	0.6	2.0	-	0.1	-	2.4	2.7	53.4	0.9%
Transmission S&W, GWh	335.0	295.8	431.3	437.0	386.2	430.1	421.2	481.9	463.3	475.0	410.2	375.4	4942.4	86.3%
Limitations, GWh	-	-	14.3	-	-	-	-	-	2.6	2.3	3.1	0.6	23.0	0.4%
Disturbance outages, GWh	-	-	-	-	-	-	-	-	-	-	0.9	-	0.9	0.0%
Unplanned maintenance, GWh	-	-	-	-	-	-	-	-	-	-	-	-	-	-
Planned maintenance, GWh	-	-	-	0.9	-	-	-	-	-	-	-	-	0.9	0.0%
Other outages, GWh	-	-	-	-	-	-	-	-	-	-	-	-	-	-
Total, GWh	485.5	438.6	487.0	472.0	486.1	471.7	486.9	488.6	470.3	483.6	468.0	486.2	5724.4	100.0%
Losses SW, GWh	-	-	-	-	-	-	-	-	-	-	-	-	-	-
Losses NE, GWh	-	-	-	-	-	-	-	-	-	-	-	-	-	-

Figure 5.24 presents the annual utilisation of EstLink 2 per utilisation and unavailability category for the years 2014–2021.

Figure 5.25 presents the percentage of hours of a year EstLink 2 has been affected by either a limitation, a disturbance outage, an unplanned or planned maintenance outage or other outage annually during the years 2014–2021.

Figure 5.26 presents the annual number of disturbance outages, unplanned and planned maintenances and other outages during the years 2014–2021.

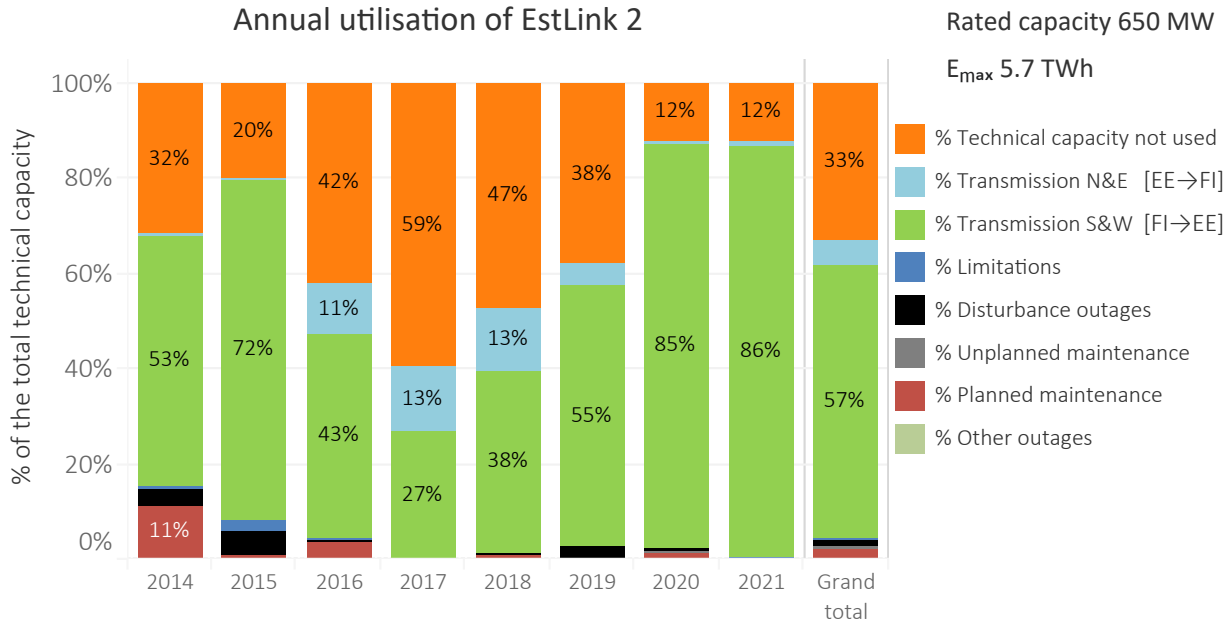

Figure 5.24: Annual utilisation of EstLink 2 per the utilisation and unavailability categories for the years 2014–2021. The utilisation and unavailability categories are described in more detail in Chapter 3.

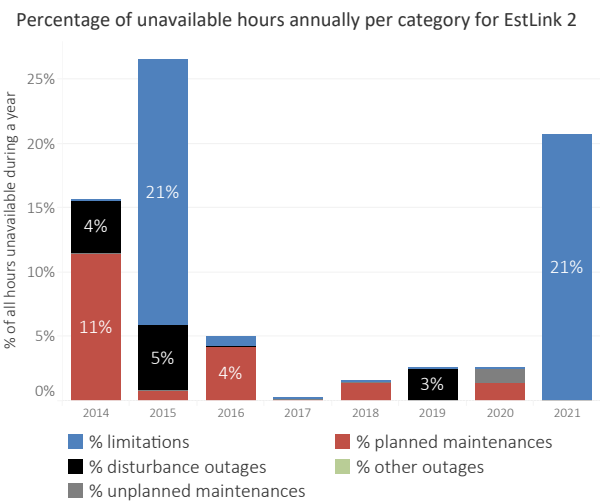

Figure 5.25: Percentage of hours EstLink 2 has been affected by either a limitation or an outage annually since 2014. The percentage is calculated by counting the number of hours with a limitation or outage and dividing it by the total number of hours in a year. It should be noted that any single hour can be affected by both an outage and a limitation.

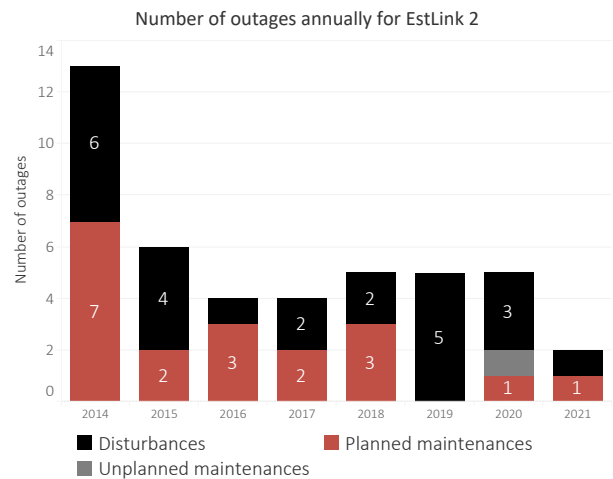

Figure 5.26: The annual number of disturbances, unplanned and planned maintenance outages and other outages for EstLink 2 for the years 2014–2021. EstLink 2 had neither unplanned maintenance nor other outages during this period.

### 5.3.5 Fenno-Skan 1

Figure 5.27 presents the availability and utilisation of Fenno-Skan 1 for 2021 and Table 5.8 presents the numerical values behind it. Fenno-Skan 1 has been in operation since 1989 and is the first HVDC connection between Finland and Sweden. In Finland (bidding zone FI), Fenno-Skan 1 is connected to Rauma and in Sweden to Dannebo (bidding zone SE3). The transmission capacity used to be 500 MW during summer and 550 MW during winter but was permanently decreased to 400 MW on 1 July 2014 after detailed DC-cable investigations were completed. The investigations were started after a cable fault 12 February 2013.

In 2021, Fenno-Skan 1 had an available technical capacity of 95 %. The technical capacity not used was 3 %. Totally, <0.1 TWh (0.7 % of the technical capacity) was transmitted west (FI→SE3) and 3.2 TWh (91 % of the technical capacity)

was transmitted east (SE3→FI).

The annual maintenance of Fenno-Skan 1 lasted 5 days in late September to early October. Additionally, there were 2 planned maintenance outages for corrective purposes — one for removing trees fallen on the neutral line, the other one for fault searching on the DC neutral bus CT. Fenno-Skan 1 had 6 disturbance outages of which 4 were due to repetitive fault in DC voltage divider and 2 due to human error. One other planned outage was due to grid operator testing at the start of the annual maintenance.

It should be noted that Fenno-Skan 1 and 2 is sometimes operated at equivalent transmission levels but with reversed directions to keep the temperature of Fenno-Skan 1 at adequate levels. The utilisation is still regarded as transmission even though the resulting net exchange between Finland and Sweden is zero.

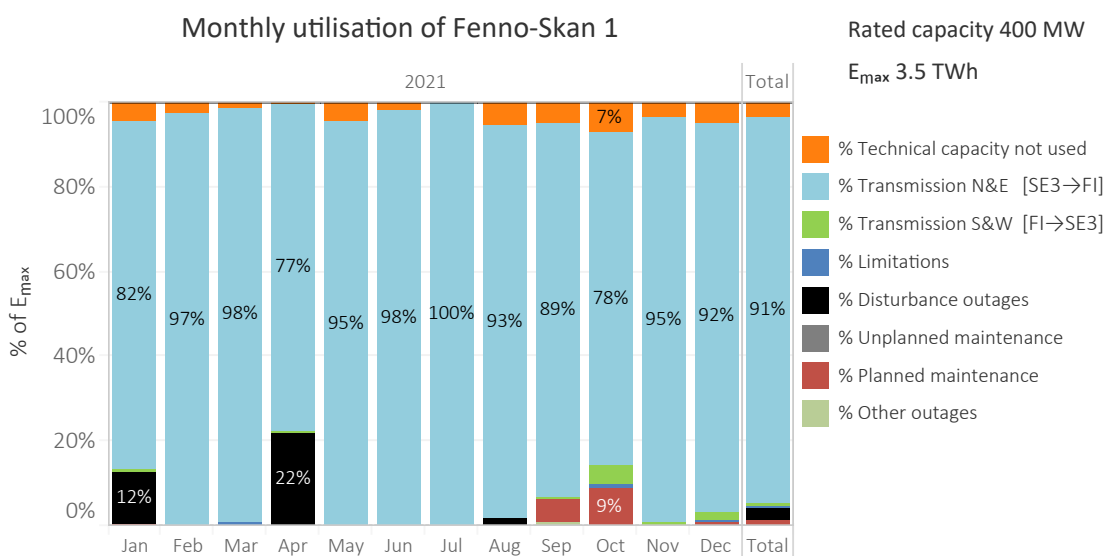

Figure 5.27: Monthly percentage allocation of utilisation by category for Fenno-Skan 1 in 2021. The availability and utilisation categories are defined in detail in Chapter 3.

Table 5.8: Monthly allocation of technical capacity (E<sub>max</sub>) for Fenno-Skan 1 in 2021. Note that losses are not included in the technical capacity (E<sub>max</sub>), as is shown in Figure 3.1.

	Jan	Feb	Mar	Apr	May	Jun	Jul	Aug	Sep	Oct	Nov	Dec	Total	% total
Technical capacity not used, GWh	13.1	6.8	4.5	0.9	13.8	5.5	-	16.2	14.0	21.7	10.6	15.3	122.2	3.5%
Transmission N&E, GWh	245.4	262.3	291.2	222.8	284.5	283.1	298.9	276.9	255.3	233.5	274.9	272.6	3201.4	91.2%
Transmission S&W, GWh	1.9	-	-	0.1	-	-	-	-	-	13.3	2.3	5.8	23.4	0.7%
Limitations, GWh	-	0.2	2.4	1.5	-	-	-	-	-	3.1	0.5	0.6	8.3	0.2%
Disturbance outages, GWh	36.2	-	-	63.4	-	0.1	-	5.3	-	-	0.1	-	105.0	3.0%
Unplanned maintenance, GWh	-	-	-	-	-	-	-	-	-	-	-	-	-	-
Planned maintenance, GWh	1.3	-	-	-	-	-	-	-	16.8	26.4	-	3.4	47.9	1.4%
Other outages, GWh	-	-	-	-	-	-	-	-	2.3	-	-	-	2.3	0.1%
Total, GWh	297.9	269.3	298.1	288.7	298.2	288.8	298.9	298.3	288.4	298.0	288.3	297.7	3510.6	100.0%
Losses SW, GWh	0.1	-	-	-	-	-	-	-	-	0.5	0.1	0.2	1.0	0.0%
Losses NE, GWh	6.7	7.0	8.3	6.1	7.7	7.4	7.5	7.5	7.0	6.0	7.4	7.1	85.7	2.4%



Figure 5.28 presents the annual utilisation of Fenno-Skan 1 per utilisation and unavailability category for the years 2012–2021.

a disturbance outage, an unplanned or planned maintenance outage or other outage annually during the years 2012–2021. Figure 5.30 presents the annual number of disturbance outages, unplanned and planned maintenances and other outages during the years 2012–2021.

Figure 5.29 presents the percentage of hours of a year Fenno-Skan 1 has been affected by either a limitation,

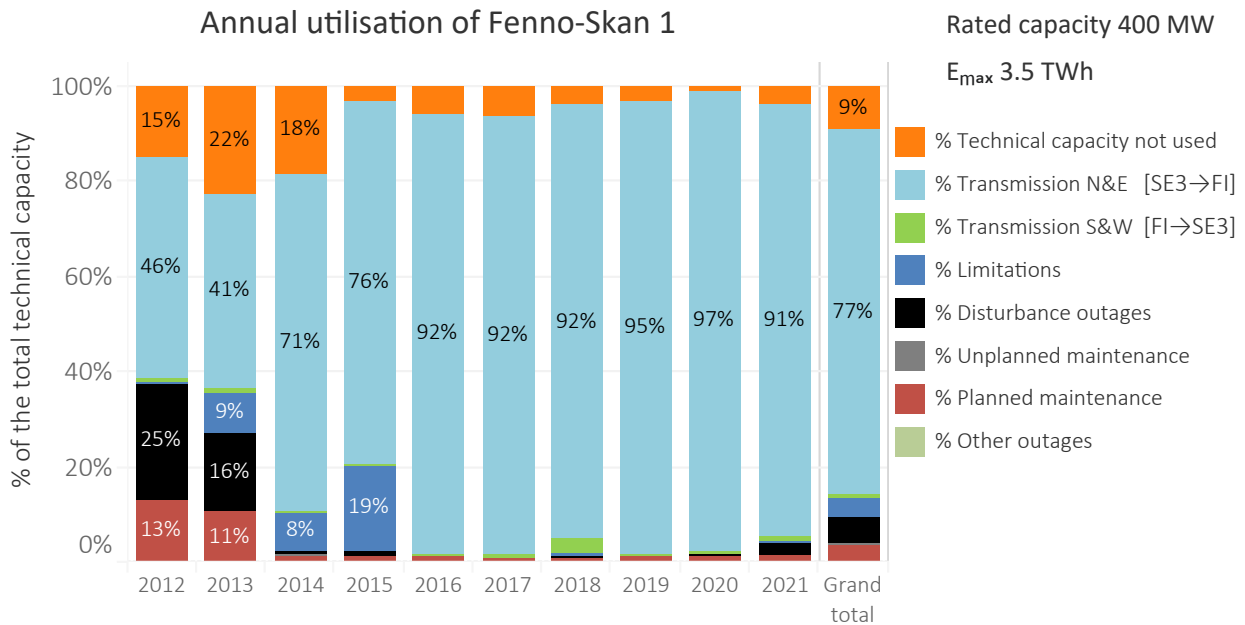

Figure 5.28: Annual utilisation of Fenno-Skan 1 per the utilisation and unavailability categories for the years 2012–2021. The utilisation and unavailability categories are described in more detail in Chapter 3.

Percentage of unavailable hours annually per category for Fenno-Skan 1

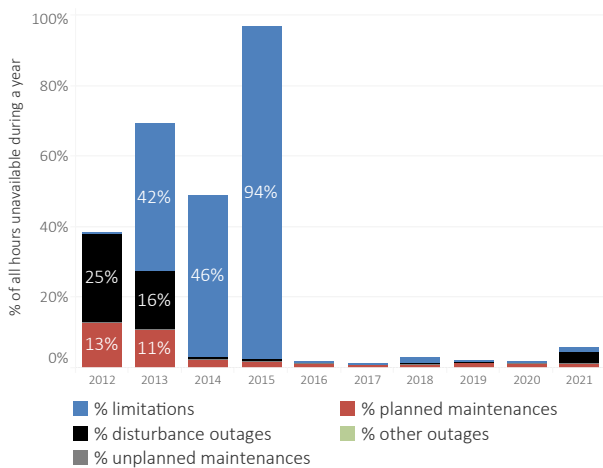

Figure 5.29: Percentage of hours Fenno-Skan 1 has been affected by either a limitation or an outage annually since 2012. The percentage is calculated by counting the number of hours with a limitation or outage and dividing it by the total number of hours in a year. It should be noted that any single hour can be affected by both an outage and a limitation.

Number of outages annually for Fenno-Skan 1

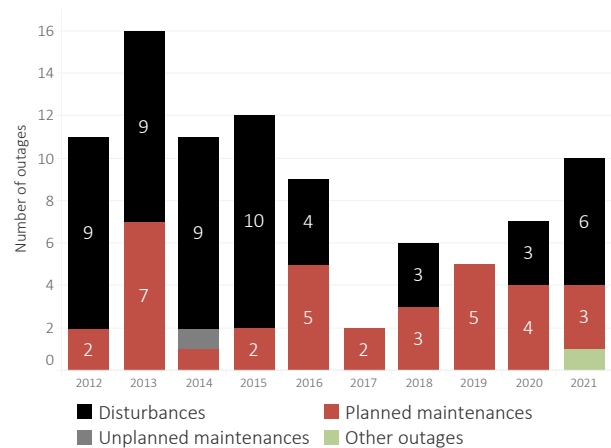

Figure 5.30: The annual number of disturbances, unplanned and planned maintenance outages and other outages for Fenno-Skan 1 during 2012–2021. Fenno-Skan 1 had no other outages during the years 2012–2021.

### 5.3.6 Fenno-Skan 2

Figure 5.31 presents the availability and utilisation of Fenno-Skan 2 for 2021 and Table 5.9 presents the numerical values behind it. Fenno-Skan 2 has been in operation since 2011 and is the second HVDC connection between Finland and Sweden. In Finland (bidding zone FI) Fenno-Skan 2 is connected to Rauma and in Sweden to Finnböle (bidding zone SE3). The transmission capacity of Fenno-Skan 2 is 800 MW.

In 2021, Fenno-Skan 2 had an available technical capacity of 83 %. The technical capacity not used was 26 %. Totally, 0.8 TWh (11 % of the technical capacity) was transmitted west (FI→SE3) and 3.1 TWh (45 % of the technical capacity) was transmitted east (SE3→FI).

The annual maintenance of Fenno-Skan 2 lasted 5 days in early October. Additionally, there were 4 planned main-

tenance outages for corrective purposes, one for removing trees fallen on the neutral line, the other one for fault searching on the DC neutral bus CT, and two for repairing after cooling water leakage at the valve hall. Fenno-Skan 2 had 4 disturbance outages. Two of them were due to loss of auxiliary power supply in Sweden and one due to a human error while switching off AC filter breaker. One other planned outage was due to AC grid testing purposes at the end of October.

It should be noted that Fenno-Skan 1 and 2 is sometimes operated at equivalent transmission levels but with reversed directions to keep the temperature of Fenno-Skan 1 at adequate levels. The utilisation is still regarded as transmission even though the resulting net exchange between Finland and Sweden is zero.

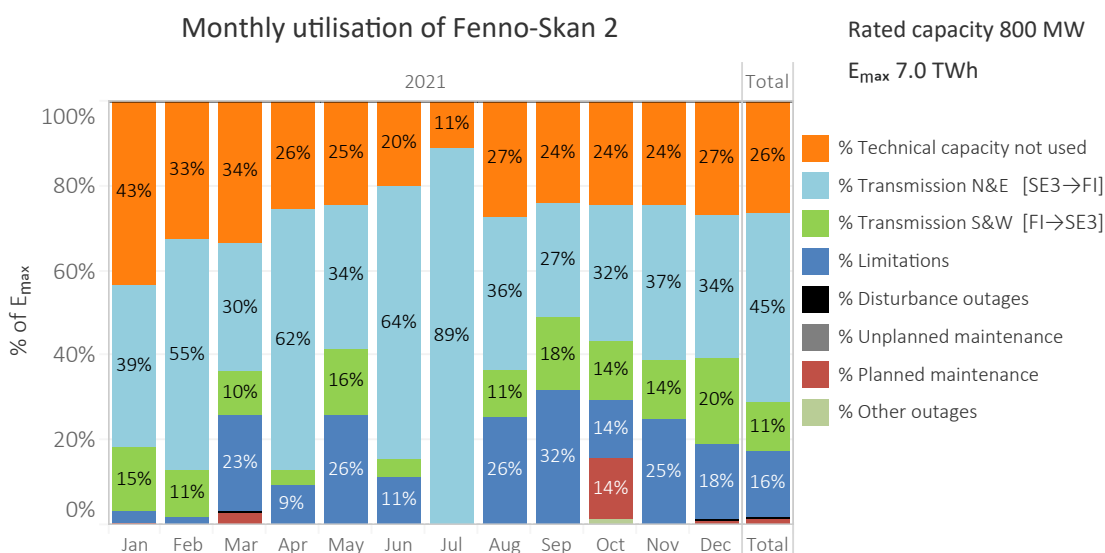

Figure 5.31: Monthly percentage allocation of utilisation by category for Fenno-Skan 2 in 2021. The availability and utilisation categories are defined in detail in Chapter 3.

Table 5.9: Monthly allocation of technical capacity (E<sub>max</sub>) for Fenno-Skan 2 in 2021. Note that losses are not included in the technical capacity (E<sub>max</sub>), as is shown in Figure 3.1.

	Jan	Feb	Mar	Apr	May	Jun	Jul	Aug	Sep	Oct	Nov	Dec	Total	% total
Technical capacity not used, GWh	257.5	175.6	199.4	147.5	146.8	115.1	65.5	163.4	138.4	145.2	141.0	158.4	1853.9	26.5%
Transmission N&E, GWh	230.0	293.5	181.2	355.1	200.5	371.0	530.0	214.5	153.6	191.1	211.3	202.1	3133.8	44.7%
Transmission S&W, GWh	89.3	58.5	60.3	20.6	94.2	25.5	-	65.5	102.3	83.1	79.5	120.5	799.2	11.4%
Limitations, GWh	15.9	9.0	135.3	52.9	153.8	64.5	-	151.9	181.7	82.7	144.3	105.8	1097.7	15.7%
Disturbance outages, GWh	-	1.0	2.7	-	-	-	-	-	-	-	-	1.5	5.2	0.1%
Unplanned maintenance, GWh	-	-	-	-	-	-	-	-	-	-	-	-	-	-
Planned maintenance, GWh	2.5	-	16.4	-	-	-	-	-	-	85.4	-	7.0	111.3	1.6%
Other outages, GWh	-	-	-	-	-	-	-	-	-	7.8	-	-	7.8	0.1%
Total, GWh	595.2	537.7	595.2	576.0	595.2	576.1	595.5	595.3	576.0	595.3	576.1	595.3	7008.8	100.0%
Losses SW, GWh	1.7	1.2	1.0	0.4	1.8	0.4	-	1.2	1.8	1.8	1.5	2.4	15.1	0.2%
Losses NE, GWh	4.2	5.8	3.2	7.3	3.9	8.0	11.8	4.3	3.0	3.8	4.0	3.9	63.1	0.9%

Figure 5.32 presents the annual utilisation of Fenno-Skan 2 per utilisation and unavailability category for the years 2012–2021.

a disturbance outage, an unplanned or planned maintenance outage or other outage annually during the years 2012–2021. Figure 5.34 presents the annual number of disturbance outages, unplanned and planned maintenances and other outages during the years 2012–2021.

Figure 5.33 presents the percentage of hours of a year Fenno-Skan 2 has been affected by either a limitation,

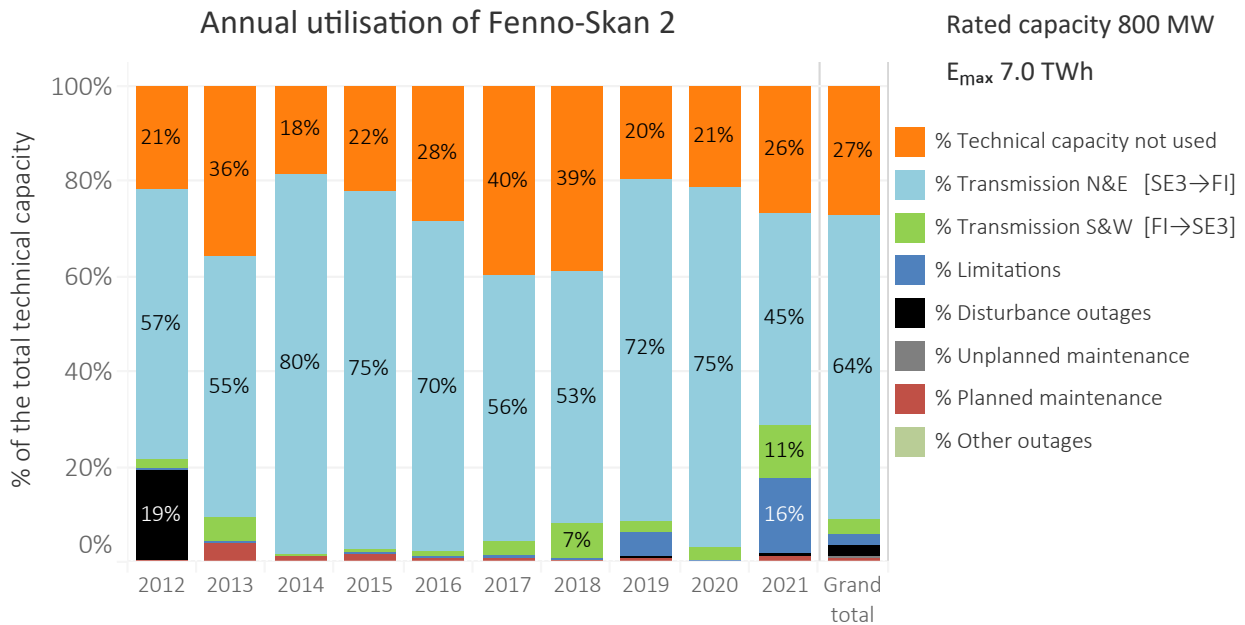

Figure 5.32: Annual utilisation of Fenno-Skan 2 per the utilisation and unavailability categories for the years 2012–2021. The utilisation and unavailability categories are described in more detail in Chapter 3.

Percentage of unavailable hours annually per category for Fenno-Skan 2

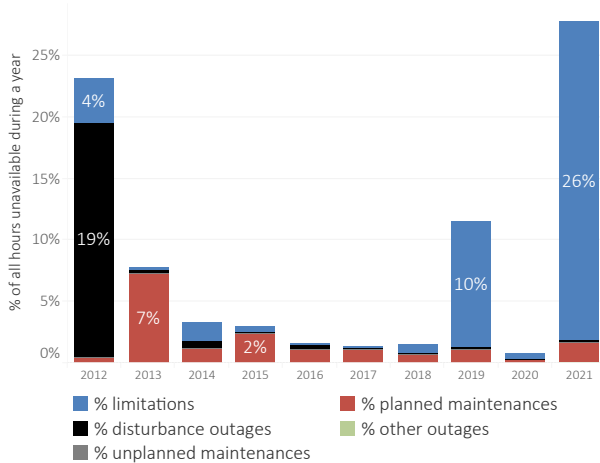

Figure 5.33: Percentage of hours Fenno-Skan 2 has been affected by either a limitation or an outage annually since 2012. The percentage is calculated by counting the number of hours with a limitation or outage and dividing it by the total number of hours in a year. It should be noted that any single hour can be affected by both an outage and a limitation.

Number of outages annually for Fenno-Skan 2

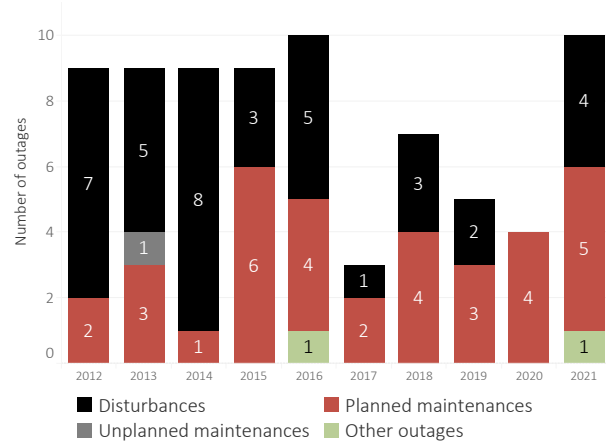

Figure 5.34: The annual number of disturbances, unplanned and planned maintenance outages and other outages for Fenno-Skan 2 for the years 2012–2021.

### 5.3.7 Kontek

Figure 5.35 presents the availability and utilisation of Kontek for 2021 and Table 5.10 presents the numerical values behind it. Kontek has been in operation since 1995. In Denmark it is connected to Bjaeverskov (bidding zone DK2) and in Germany to Bentwisch (bidding zone DE-50Hertz). The transmission capacity of Kontek is 600 MW.

In 2021, Kontek had an available technical capacity of 70 %. The technical capacity not used was 23 %. Totally, 1.6 TWh

(30 % of the technical capacity) was transmitted south from Denmark to Germany and 0.9 TWh (18 % of the technical capacity) was transmitted north to Denmark.

Kontek had no disturbance outages in 2021. There were four planned maintenance outages: one was the annual maintenance, two were due to cable joint inspection due to oil leak and repair of that joint, and the last one was maintenance work on the converter transformer.

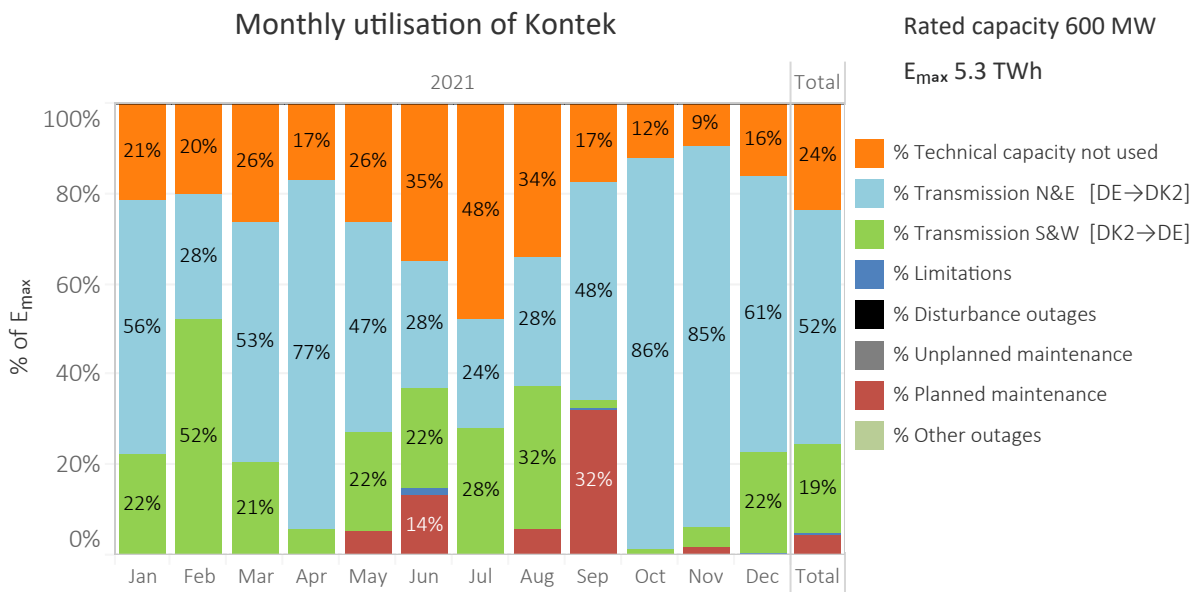

Figure 5.35: Monthly percentage allocation of utilisation by category for Kontek in 2021. The availability and utilisation categories are defined in detail in Chapter 3.

Table 5.10: Monthly allocation of technical capacity (E<sub>max</sub>) for Kontek in 2021. Note that losses are not included in the technical capacity (E<sub>max</sub>), as is shown in Figure 3.1.

Monthly utilisation of Kontek (South & West direction DK2→DE)														Total	% total
	Jan	Feb	Mar	Apr	May	Jun	Jul	Aug	Sep	Oct	Nov	Dec	Total	% total	
Technical capacity not used, GWh	94.9	81.0	116.6	73.8	117.2	151.1	212.6	152.1	74.9	54.3	40.5	71.8	1240.8	23.6%	
Transmission N&E, GWh	252.1	111.1	237.4	333.1	208.5	121.3	107.9	126.3	208.1	385.4	365.1	273.6	2729.9	51.9%	
Transmission S&W, GWh	99.4	211.1	92.3	25.0	97.6	96.8	125.9	142.8	8.4	6.7	19.2	99.3	1024.6	19.5%	
Limitations, GWh	-	-	-	-	-	4.3	-	-	0.7	-	-	1.7	6.7	0.1%	
Disturbance outages, GWh	-	-	-	-	-	-	-	-	-	-	-	-	-	-	
Unplanned maintenance., GWh	-	-	-	-	-	-	-	-	-	-	-	-	-	-	
Planned maintenance, GWh	-	-	-	-	23.2	58.6	-	25.2	140.0	-	7.1	-	254.0	4.8%	
Other outages, GWh	-	-	-	-	-	-	-	-	-	-	-	-	-	-	
Total, GWh	446.4	403.2	446.4	432.0	446.4	432.0	446.4	446.4	432.0	446.4	432.0	446.4	5256.0	100.0%	
Losses SW, GWh	2.0	4.4	1.9	0.5	2.0	1.9	2.5	2.9	0.2	0.1	0.4	2.0	20.8	0.4%	
Losses NE, GWh	5.3	2.3	4.9	7.1	4.3	2.4	2.2	2.6	4.4	8.2	7.8	6.0	57.5	1.1%	

Figure 5.36 presents the annual utilisation of Kontek per utilisation and unavailability category for the years 2012–2021.

Figure 5.37 presents the percentage of hours of a year Kontek has been affected by either a limitation, a distur-

bance outage, an unplanned or planned maintenance outage or other outage annually during the years 2012–2021. Figure 5.38 presents the annual number of disturbance outages, unplanned and planned maintenances and other outages during the years 2012–2021.

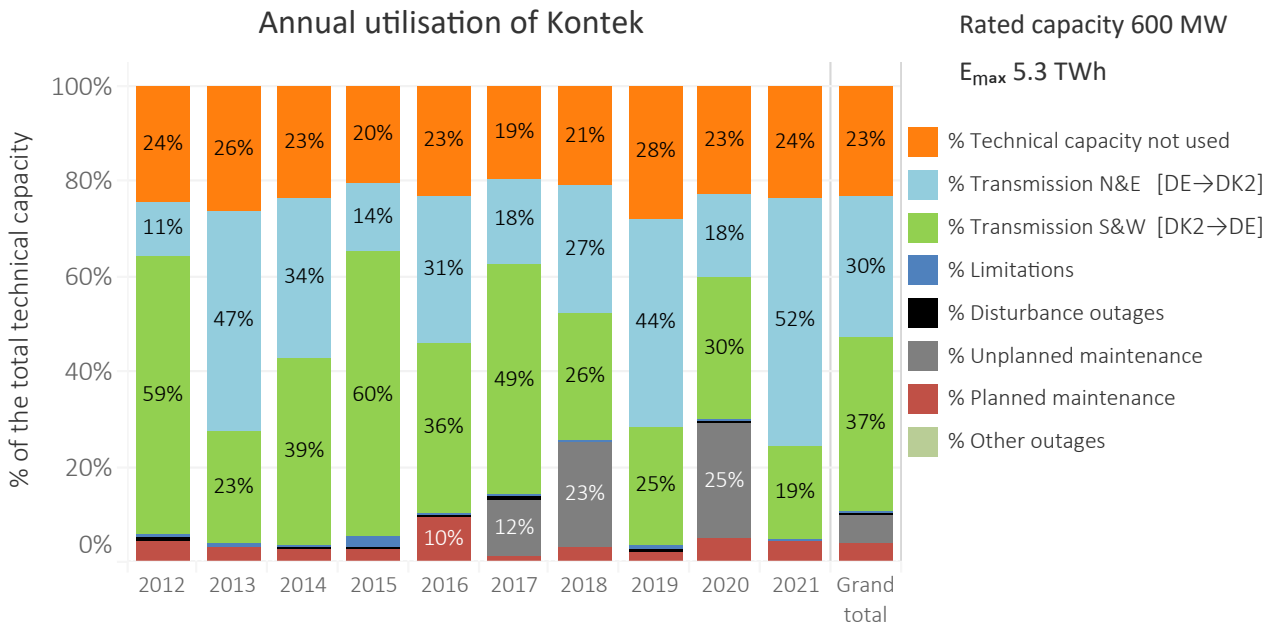

Figure 5.36: Annual utilisation of Kontek per the utilisation and unavailability categories for the years 2012–2021. The utilisation and unavailability categories are described in more detail in Chapter 3.

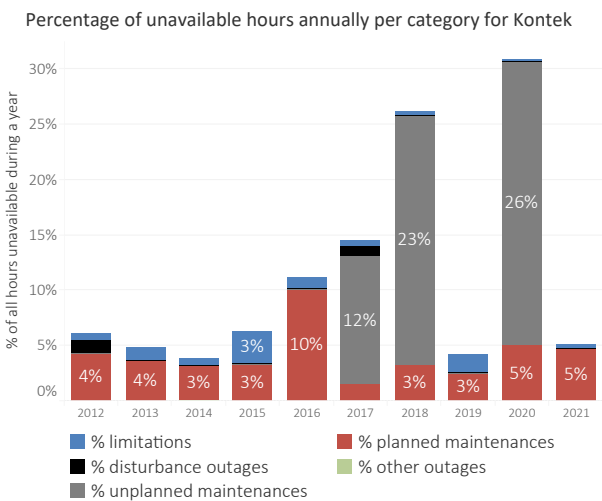

Figure 5.37: Percentage of hours Kontek has been affected by either a limitation or an outage annually since 2012. The percentage is calculated by counting the number of hours with a limitation or outage and dividing it by the total number of hours in a year. It should be noted that any single hour can be affected by both an outage and a limitation.

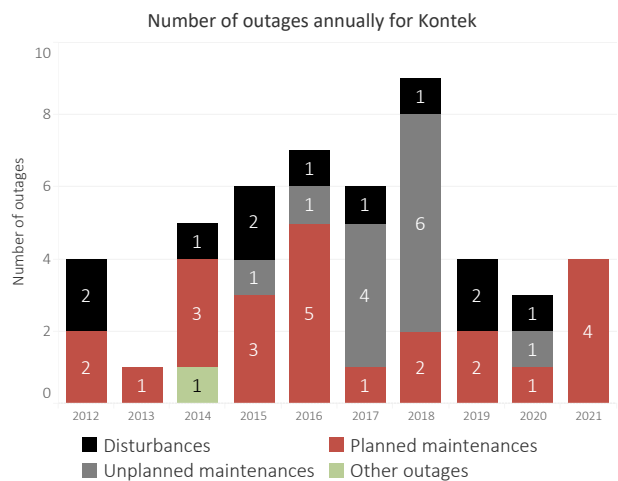

Figure 5.38: The annual number of disturbances, unplanned and planned maintenance outages and other outages for Kontek for the years 2012–2021.

### 5.3.8 Konti-Skan 1

Figure 5.39 presents the availability and utilisation of Konti-Skan 1 for 2021 and Table 5.11 presents the numerical values behind it. Konti-Skan 1 has been in operation since 1965 and it is connected in south-western Sweden to Lindome (bidding zone SE3) and in Denmark to Vester Hassing (bidding zone DK1).

The rated capacity of Konti-Skan 1 and 2 was updated to 715 MW in both directions on 1 February 2020 (357.5 MW per link). The rated capacity was previously asymmetric depending on the flow direction: 740 MW towards east (370+370) and 680 MW towards west (340+340). The reason of the asymmetric rated capacity was due to historical limitations and reserve requirements, along with transmission measurements only being done in DK1.

In 2021, Konti-Skan 1 had an available technical capacity of 85 % and the technical capacity not used was 39 %. Totally, 0.4 TWh (14 % of the technical capacity) was transmitted west to Denmark (SE3→DK1) and 1.0 TWh (32 % of the technical capacity) was transmitted east to Sweden (DK1→SE3).

Annual maintenance of Konti-Skan 1 lasted 6 days in September, and there was one minor unplanned maintenance due to an oil leakage from a condenser in December. Konti-Skan 1 had six disturbance outages were a cable fault on the land cable was most severe. The other five were minor and due to either ELIS protection or during exchange of auxiliary system due to an error in the converter protection.

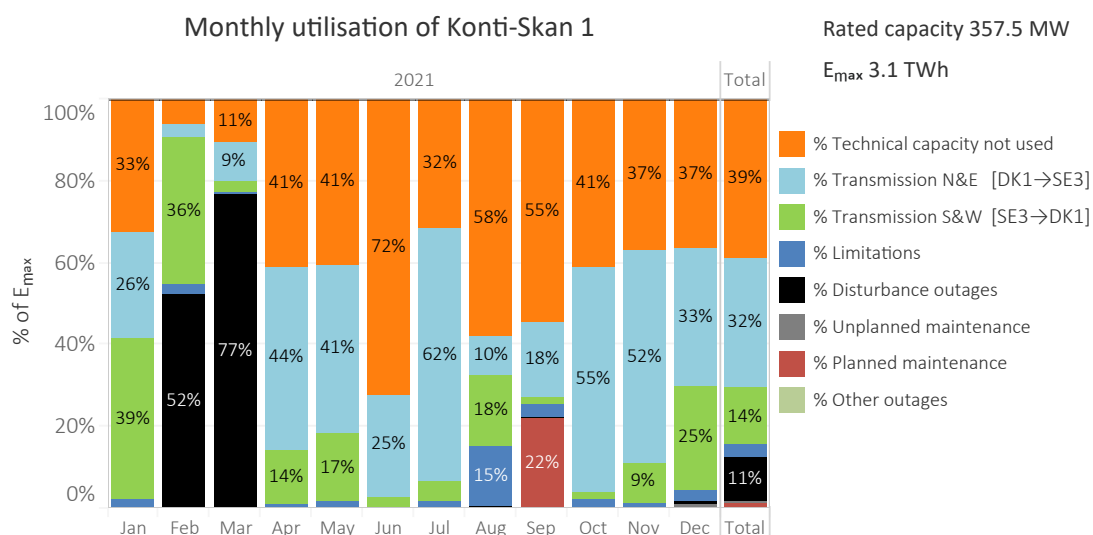

Figure 5.39: Monthly percentage allocation of utilisation by category for Konti-Skan 1 in 2021. The availability and utilisation categories are defined in detail in Chapter 3.

Table 5.11: Monthly allocation of technical capacity (E<sub>max</sub>) for Konti-Skan 1 in 2021. Note that losses are not included in the technical capacity (E<sub>max</sub>), as is shown in Figure 3.1.

	Jan	Feb	Mar	Apr	May	Jun	Jul	Aug	Sep	Oct	Nov	Dec	Total	% total
Technical capacity not used, GWh	86.5	15.1	27.9	106.2	108.5	186.2	83.8	153.9	140.6	109.0	95.1	97.6	1210.4	38.6%
Transmission N&E, GWh	68.7	7.1	25.2	113.8	108.4	63.7	164.7	25.5	46.5	146.0	134.1	89.1	992.9	31.7%
Transmission S&W, GWh	104.9	86.0	7.5	34.8	44.9	6.8	12.8	46.6	5.1	5.4	24.4	67.0	446.1	14.2%
Limitations, GWh	5.8	6.8	1.4	2.5	4.3	0.7	4.7	39.3	8.3	5.6	3.3	8.3	90.8	2.9%
Disturbance outages, GWh	-	125.3	204.0	-	-	-	-	0.8	0.6	-	0.4	1.8	333.0	10.6%
Unplanned maintenance, GWh	-	-	-	-	-	-	-	-	-	-	-	2.4	2.4	0.1%
Planned maintenance, GWh	-	-	-	-	-	-	-	-	56.3	-	-	-	56.3	1.8%
Other outages, GWh	-	-	-	-	-	-	-	-	-	-	-	-	-	-
Total, GWh	266.0	240.2	266.0	257.4	266.0	257.4	266.0	266.0	257.4	266.0	257.4	266.1	3132.0	100.0%
Losses SW, GWh	2.4	2.0	0.2	0.9	1.1	0.2	0.3	1.0	0.2	0.1	0.6	1.6	10.7	0.3%
Losses NE, GWh	1.4	0.1	0.4	2.0	2.0	1.1	3.5	0.4	0.9	2.7	2.6	1.8	19.1	0.6%

Figure 5.40 presents the annual utilisation of Konti-Skan 1 per utilisation and unavailability category for the years 2012–2021.

turbance outage, an unplanned or planned maintenance outage or other outage annually during the years 2012–2021. Figure 5.42 presents the annual number of disturbance outages, unplanned and planned maintenances and other outages during the years 2012–2021.

Figure 5.41 presents the percentage of hours of a year Konti-Skan 1 has been affected by either a limitation, a dis-

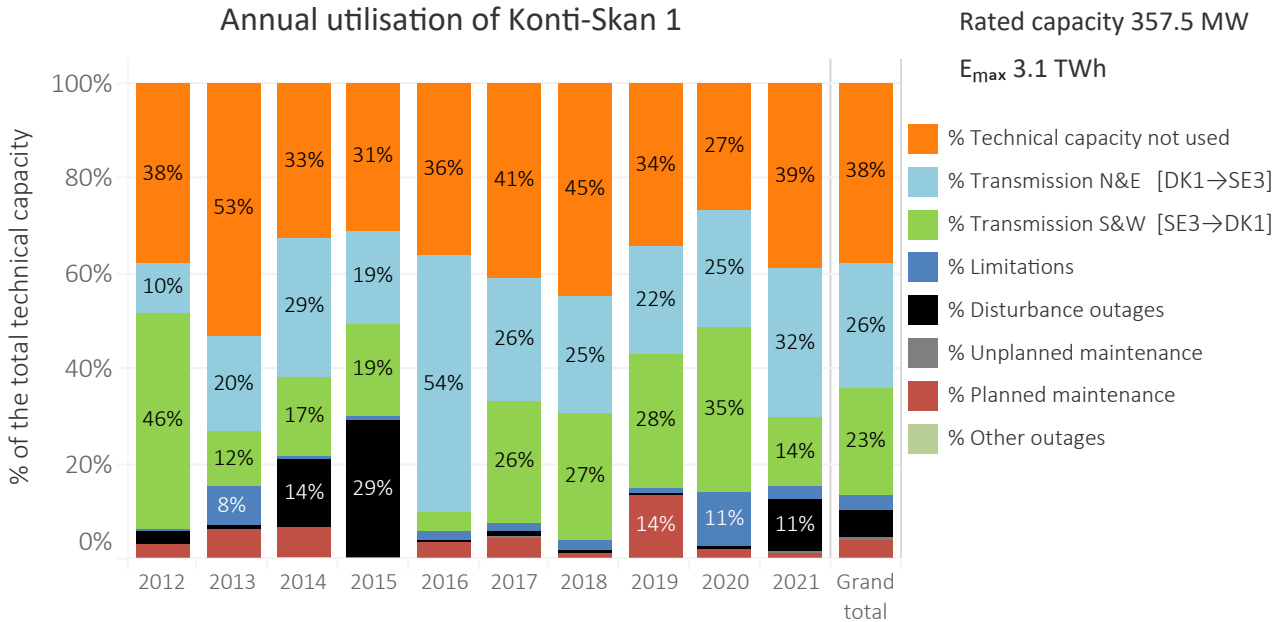

Figure 5.40: Annual utilisation of Konti-Skan 1 per the utilisation and unavailability categories for the years 2012–2021. The utilisation and unavailability categories are described in more detail in Chapter 3.

Percentage of unavailable hours annually per category for Konti-Skan 1

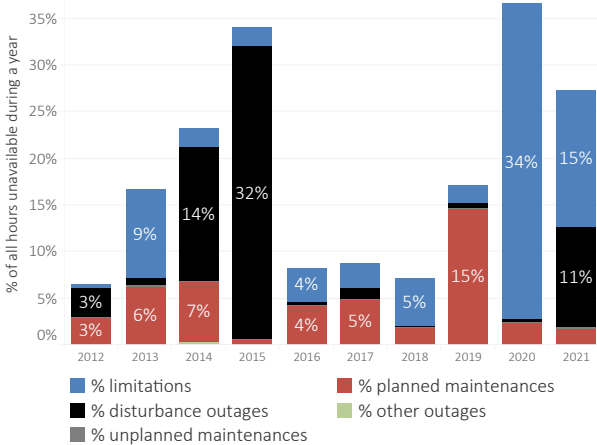

Figure 5.41: Percentage of hours Konti-Skan 1 has been affected by either a limitation or an outage annually since 2012. The percentage is calculated by counting the number of hours with a limitation or outage and dividing it by the total number of hours in a year. It should be noted that any single hour can be affected by both an outage and a limitation.

Number of outages annually for Konti-Skan 1

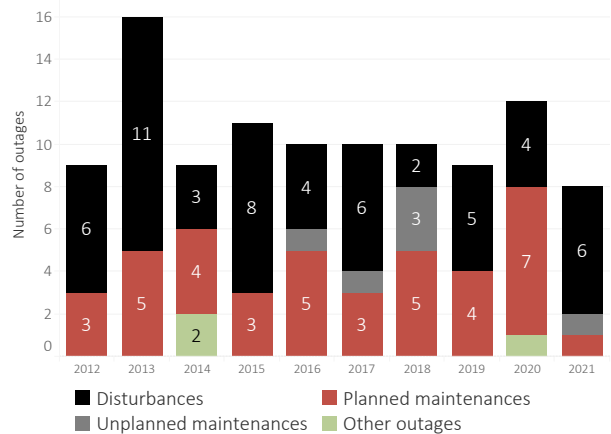

Figure 5.42: The annual number of disturbances, unplanned and planned maintenance outages and other outages for Konti-Skan 1 for the years 2012–2021.

### 5.3.9 Konti-Skan 2

Figure 5.43 presents the availability and utilisation of Konti-Skan 2 for 2021 and Table 5.12 presents the numerical values behind it. Konti-Skan 2 is connected between Sweden and Denmark in parallel to Konti-Skan 1 and has been in operation since 1988.

The rated capacity of Konti-Skan 1 and 2 was updated to 715 MW in both directions on 1 February 2020 (357.5 MW per link). The rated capacity was previously asymmetric depending on the flow direction: 740 MW towards east (370+370) and 680 MW towards west (340+340). The reason of the asymmetric rated capacity was due to historical limitations and reserve requirements, along with transmis-

sion measurements only being done in DK1.

In 2021, Konti-Skan 2 had an available technical capacity of 94 % and the technical capacity not used was 42 %. Totally, 0.5 TWh (16 % of the technical capacity) was transmitted west to Denmark (SE3→DK1) and 1.1 TWh (36 % of the technical capacity) was transmitted east to Sweden (DK1→SE3).

Annual maintenance for Konti-Skan 2 lasted 6 days in September. There were five minor disturbances of which the most severe one was a fault in Konti-Skan 2's new 132 kV AC breaker.

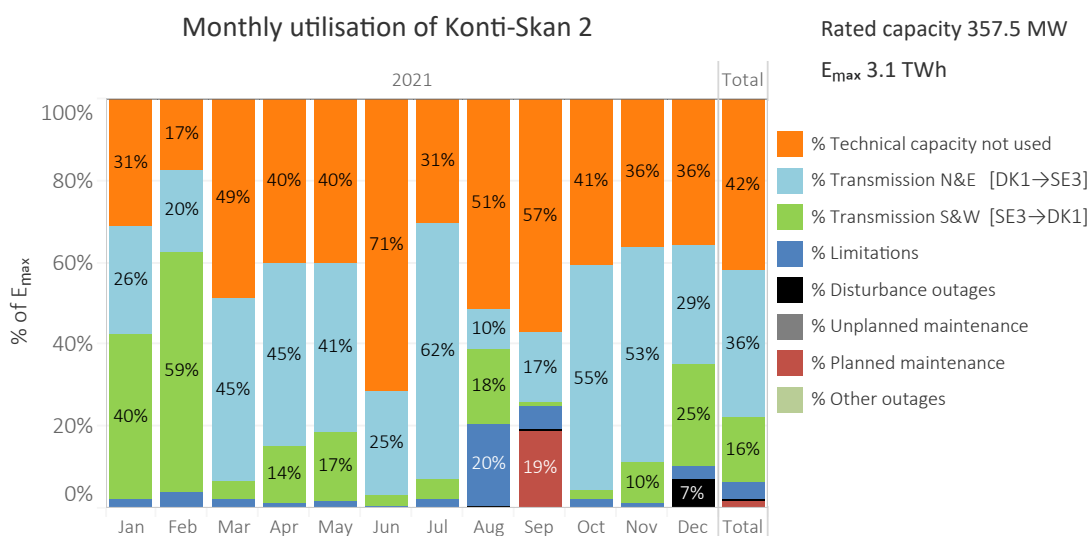

Figure 5.43: Monthly percentage allocation of utilisation by category for Konti-Skan 2 in 2021. The availability and utilisation categories are defined in detail in Chapter 3.

Table 5.12: Monthly allocation of technical capacity (E<sub>max</sub>) for Konti-Skan 2 in 2021. Note that losses are not included in the technical capacity (E<sub>max</sub>), as is shown in Figure 3.1.

Monthly utilisation of Konti-Skan 2 (South & West direction SE3→DK1)														
	Jan	Feb	Mar	Apr	May	Jun	Jul	Aug	Sep	Oct	Nov	Dec	Total	% total
Technical capacity not used, GWh	83.5	41.6	129.3	103.9	107.0	183.9	81.4	136.9	147.4	107.8	93.2	95.0	1310.9	41.9%
Transmission N&E, GWh	69.9	48.5	119.2	115.0	109.5	65.2	166.5	26.2	43.1	146.7	135.6	77.0	1122.3	35.8%
Transmission S&W, GWh	106.4	140.5	12.1	35.4	45.3	7.6	12.9	47.9	2.7	5.8	25.0	66.5	508.3	16.2%
Limitations, GWh	6.2	9.5	5.4	3.2	4.2	0.6	5.7	54.0	14.2	5.7	3.6	8.3	120.8	3.9%
Disturbance outages, GWh	-	-	-	-	-	-	-	0.9	0.6	-	-	19.1	20.7	0.7%
Unplanned maintenance, GWh	-	-	-	-	-	-	-	-	-	-	-	-	-	-
Planned maintenance, GWh	-	-	-	-	-	-	-	-	49.3	-	-	-	49.3	1.6%
Other outages, GWh	-	-	-	-	-	-	-	-	-	-	-	-	-	-
Total, GWh	266.0	240.2	266.0	257.4	266.0	257.4	266.5	266.0	257.4	266.0	257.4	266.0	3132.3	100.0%
Losses SW, GWh	2.7	4.0	0.3	0.9	1.1	0.2	0.3	1.2	0.1	0.1	0.6	1.7	13.3	0.4%
Losses NE, GWh	1.5	1.4	3.3	2.3	2.2	1.2	3.9	0.5	0.9	2.9	2.8	1.6	24.4	0.8%



Figure 5.44 presents the annual utilisation of Konti-Skan 2 per utilisation and unavailability category for the years 2012–2021.

turbance outage, an unplanned or planned maintenance outage or other outage annually during the years 2012–2021. Figure 5.46 presents the annual number of disturbance outages, unplanned and planned maintenances and other outages during the years 2012–2021.

Figure 5.45 presents the percentage of hours of a year Konti-Skan 2 has been affected by either a limitation, a dis-

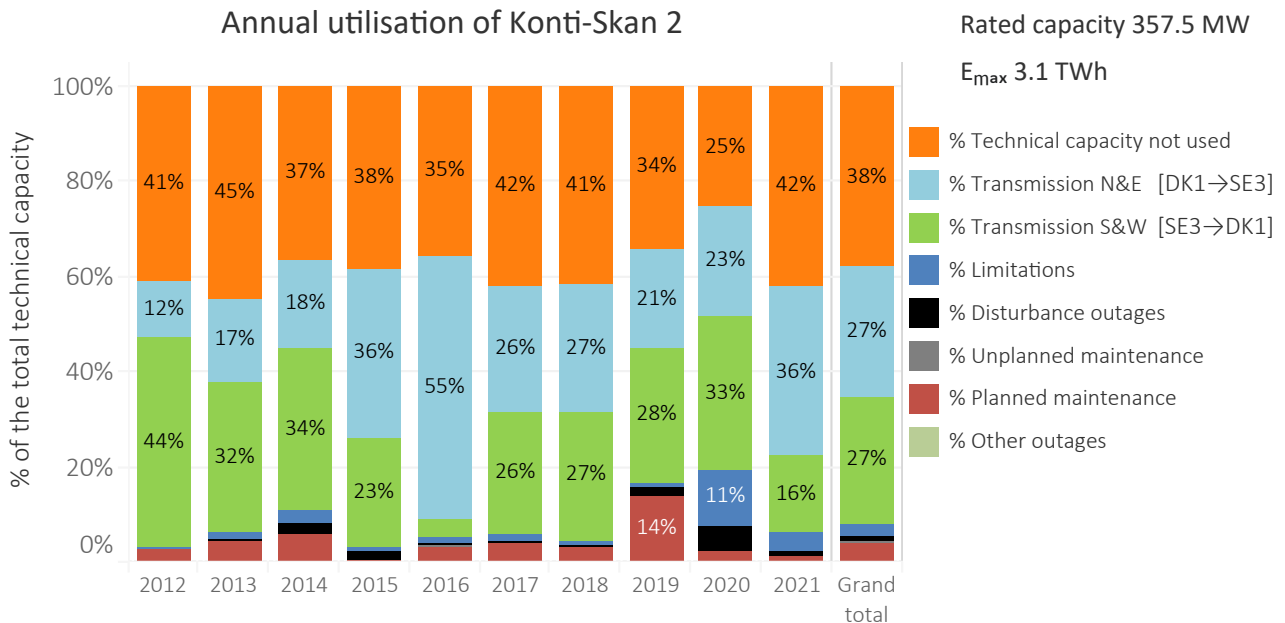

Figure 5.44: Annual utilisation of Konti-Skan 2 per the utilisation and unavailability categories for the years 2012–2021. The utilisation and unavailability categories are described in more detail in Chapter 3.

Percentage of unavailable hours annually per category for Konti-Skan 2

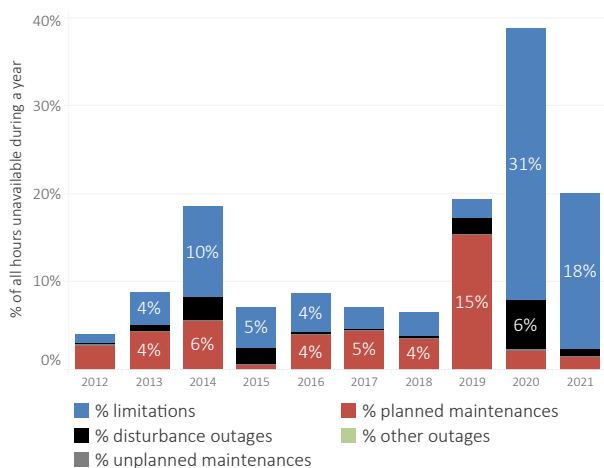

Figure 5.45: Percentage of hours Konti-Skan 2 has been affected by either a limitation or an outage annually since 2012. The percentage is calculated by counting the number of hours with a limitation or outage and dividing it by the total number of hours in a year. It should be noted that any single hour can be affected by both an outage and a limitation.

Number of outages annually for Konti-Skan 2

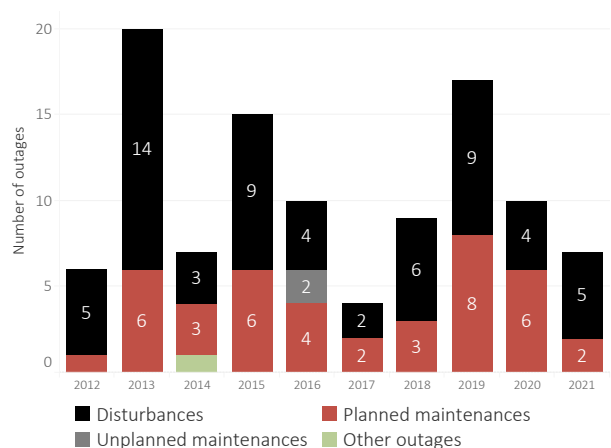

Figure 5.46: The annual number of disturbances, unplanned and planned maintenance outages and other outages for Konti-Skan 2 for the years 2012–2021.

### 5.3.10 LitPol Link

Figure 5.47 presents the availability and utilisation of LitPol Link for 2021 and Table 4.1 presents the numerical values behind it. LitPol Link has been in operation since the end of 2015. In Lithuania, it is connected to Alytus (bidding zone LT) and in Poland to Elk (bidding zone PL). The transmission capacity of LitPol Link is 500 MW.

In 2021, LitPol Link had an available technical capacity of 87 %. The technical capacity not used was 32 %. Totally, 1.7 TWh (39 % of the technical capacity) as transmitted west (LT→PL) and 0.7 TWh (16 % of the technical capacity)

was transmitted east (PL→LT).

The annual maintenance of LitPol Link lasted 25 days in May. The annual maintenance was longer than expected due to unplanned replacement of the bushing of a converter transformer. Additionally, there were 12 maintenance outages of which 8 were caused by external AC grid corrective maintenance. Last, LitPol Link had 5 disturbance outages and 4 other outages (for the tests in AC external grid) with minimal impact in 2021.

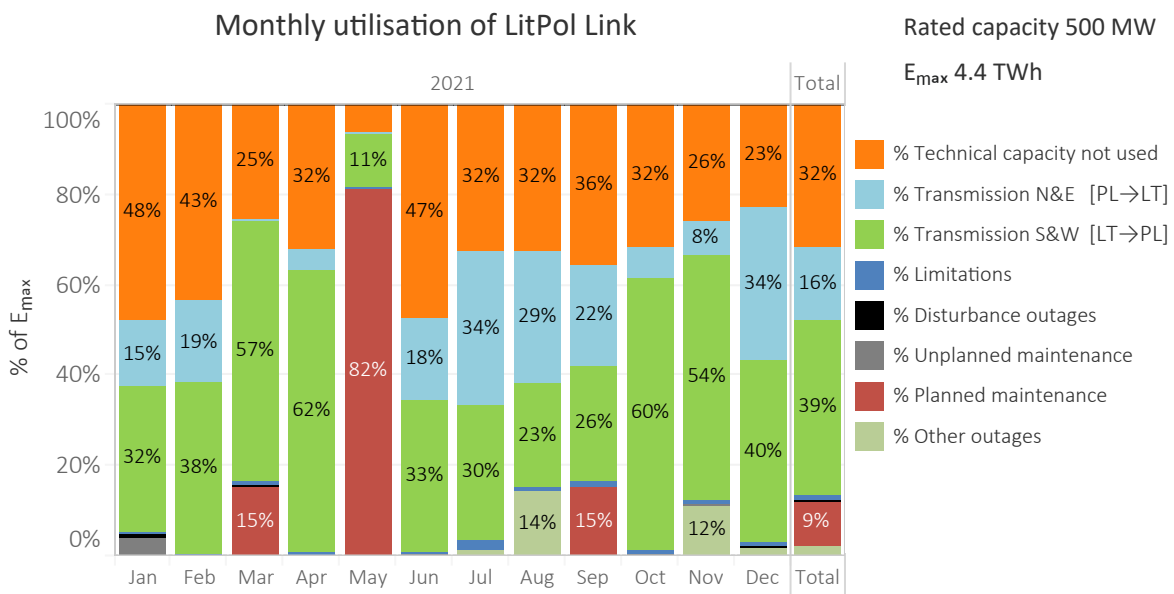

Figure 5.47: Monthly percentage allocation of utilisation by category for LitPol Link in 2021. The availability and utilisation categories are defined in detail in Chapter 3.

Table 5.13: Monthly allocation of technical capacity (E<sub>max</sub>) for LitPol Link in 2021. Note that losses are not included in the technical capacity (E<sub>max</sub>), as is shown in Figure 3.1.

	Jan	Feb	Mar	Apr	May	Jun	Jul	Aug	Sep	Oct	Nov	Dec	Total	% total
Technical capacity not used, GWh	177.6	145.0	94.0	116.2	23.3	170.6	120.7	120.7	129.1	118.6	92.8	85.2	1394.0	31.8%
Transmission N&E, GWh	55.7	62.3	2.4	15.7	2.2	66.0	126.3	108.7	79.2	23.7	27.6	125.6	695.5	15.9%
Transmission S&W, GWh	118.2	126.7	213.6	224.9	42.4	119.9	111.4	86.4	92.0	224.3	194.1	149.6	1703.5	38.9%
Limitations, GWh	1.9	2.1	3.5	3.2	0.5	1.9	8.5	3.5	5.2	3.3	3.1	4.0	40.8	0.9%
Disturbance outages, GWh	3.7	-	1.3	-	-	-	-	-	-	-	-	1.6	6.6	0.1%
Unplanned maintenance, GWh	15.0	-	-	-	-	1.5	-	-	-	2.0	1.0	-	19.5	0.4%
Planned maintenance, GWh	-	-	57.2	-	303.5	-	-	-	54.5	-	-	-	415.1	9.5%
Other outages, GWh	-	-	-	-	-	-	5.0	52.6	-	-	41.4	6.0	105.0	2.4%
Total, GWh	372.0	336.0	372.0	360.0	372.0	360.0	372.0	372.0	360.0	372.0	360.0	372.0	4380.0	100.0%
Losses SW, GWh	1.9	2.0	3.1	3.4	0.6	2.0	1.8	1.4	1.6	3.5	2.8	2.2	26.5	0.6%
Losses NE, GWh	1.0	1.0	0.1	0.3	-	1.2	2.0	1.7	1.3	0.5	0.5	2.0	11.5	0.3%

Figure 5.48 presents the annual utilisation of LitPol Link per utilisation and unavailability category for the years 2016–2021.

Figure 5.49 presents the percentage of hours of a year LitPol Link has been affected by either a limitation, a dis-

turbance outage, an unplanned or planned maintenance outage or other outage annually during the years 2016–2021. Figure 5.50 presents the annual number of disturbance outages, unplanned and planned maintenances and other outages during the years 2016–2021.

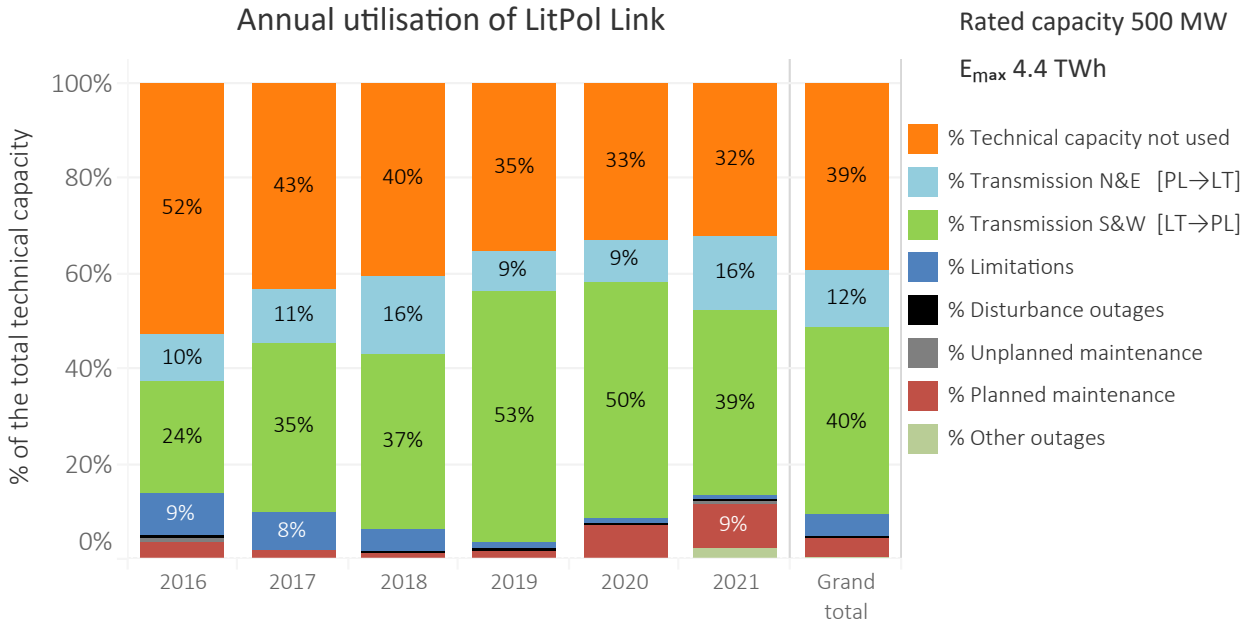

Figure 5.48: Annual utilisation of LitPol Link per the utilisation and unavailability categories for the years 2016–2021. The utilisation and unavailability categories are described in more detail in Chapter 3.

Percentage of unavailable hours annually per category for LitPol Link

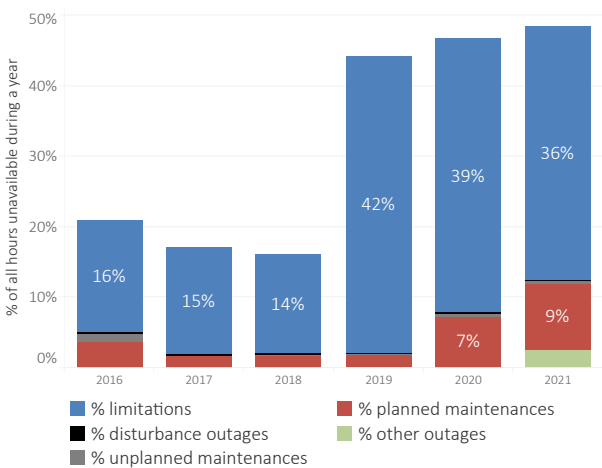

Figure 5.49: Percentage of hours LitPol Link has been affected by either a limitation or an outage annually since 2016. The percentage is calculated by counting the number of hours with a limitation or outage and dividing it by the total number of hours in a year. It should be noted that any single hour can be affected by both an outage and a limitation.

Number of outages annually for LitPol Link

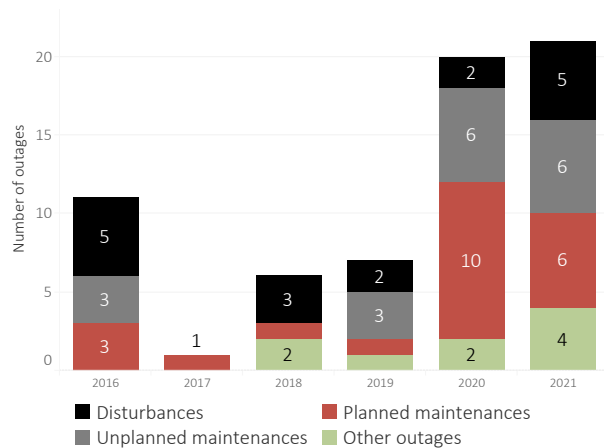

Figure 5.50: The annual number of disturbances, unplanned and planned maintenance outages and other outages for LitPol Link for the years 2016–2021.

### 5.3.11 NordBalt

Figure 5.51 presents the availability and utilisation of NordBalt for 2021 and Table 5.14 presents the numerical values behind it. NordBalt has been in operation since 2016. In Sweden, it is connected to Nybro (bidding zone SE4) and in Lithuania to Klaipeda (bidding zone LT). The transmission capacity of NordBalt is 700 MW at the receiving end.

In 2021, NordBalt had an available technical capacity of 94 %. The technical capacity not used was 34 %. Totally, 3.4 TWh (56 % of the technical capacity) was transmitted

south to Lithuania (SE4→LT) and 0.3 TWh (4 % of the technical capacity) was transmitted north to Sweden (LT→SE4).

The annual maintenance of Nordbalt lasted 7 days in September. Additionally, Nordbalt had 1 short planned outage for corrective maintenance. Nordbalt had one short disturbance in 2021 due to a problem with sensors of the door to the DC valve hall in the converter station in Nybro.

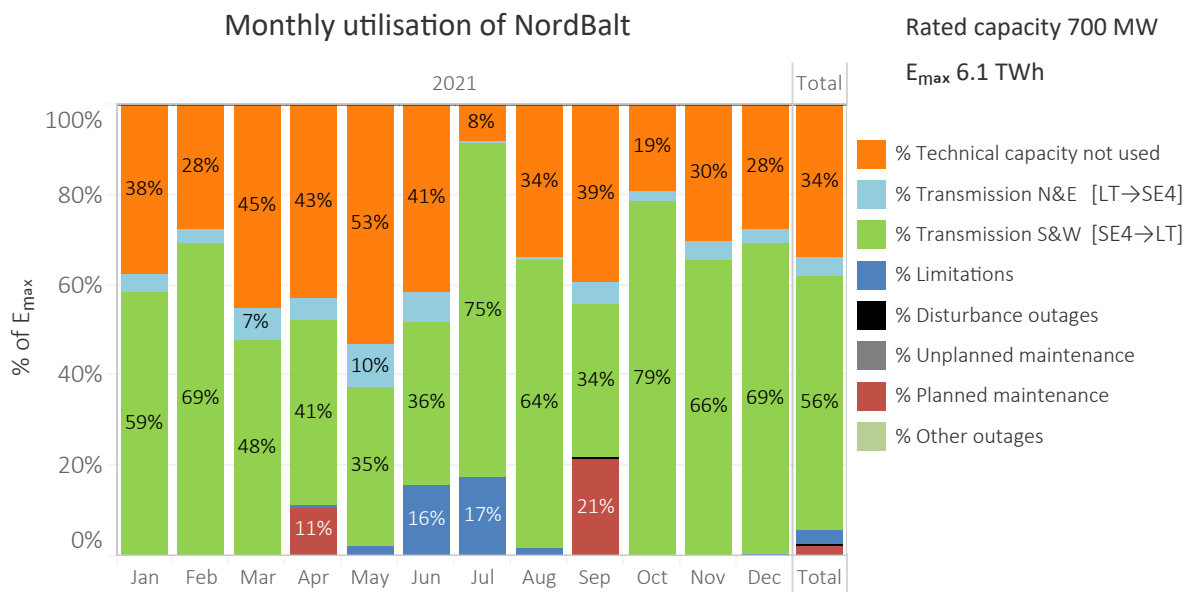

Figure 5.51: Monthly percentage allocation of utilisation by category for NordBalt in 2021. The availability and utilisation categories are defined in detail in Chapter 3.

Table 5.14: Monthly allocation of technical capacity (E<sub>max</sub>) for NordBalt in 2021. Note that losses are not included in the technical capacity (E<sub>max</sub>), as is shown in Figure 3.1.

	Jan	Feb	Mar	Apr	May	Jun	Jul	Aug	Sep	Oct	Nov	Dec	Total	% total
Technical capacity not used, GWh	196.3	131.1	235.7	215.0	275.7	208.9	40.9	176.4	197.3	100.0	152.6	143.7	2073.7	33.8%
Transmission N&E, GWh	19.5	12.8	35.2	25.0	50.6	33.7	0.6	3.2	25.2	10.7	19.8	16.8	253.2	4.1%
Transmission S&W, GWh	305.0	326.5	249.9	207.5	183.0	183.0	389.6	332.5	171.8	410.1	331.6	357.2	3447.6	56.2%
Limitations, GWh	-	-	-	0.1	11.5	78.3	89.7	8.7	-	-	-	3.1	191.5	3.1%
Disturbance outages, GWh	-	-	-	-	-	-	-	-	2.4	-	-	-	2.4	0.0%
Unplanned maintenance., GWh	-	-	-	-	-	-	-	-	-	-	-	-	-	-
Planned maintenance, GWh	-	-	-	56.4	-	-	-	-	107.3	-	-	-	163.6	2.7%
Other outages, GWh	-	-	-	-	-	-	-	-	-	-	-	-	-	-
Total, GWh	520.8	470.4	520.8	504.0	520.8	504.0	520.8	520.8	504.0	520.8	504.0	520.8	6132.0	100.0%
Losses SW, GWh	13.2	14.4	10.6	8.6	7.3	6.6	15.3	14.0	7.0	18.8	14.6	15.8	146.2	2.4%
Losses NE, GWh	0.7	0.4	1.3	0.8	1.8	1.2	-	0.2	0.9	0.3	0.7	0.6	9.0	0.1%

Figure 5.52 presents the annual utilisation of NordBalt per utilisation and unavailability category for the years 2016–2021.

Figure 5.53 presents the percentage of hours of a year NordBalt has been affected by either a limitation, a dis-

turbance outage, an unplanned or planned maintenance outage or other outage annually during the years 2016–2021. Figure 5.54 presents the annual number of disturbance outages, unplanned and planned maintenances and other outages during the years 2016–2021.

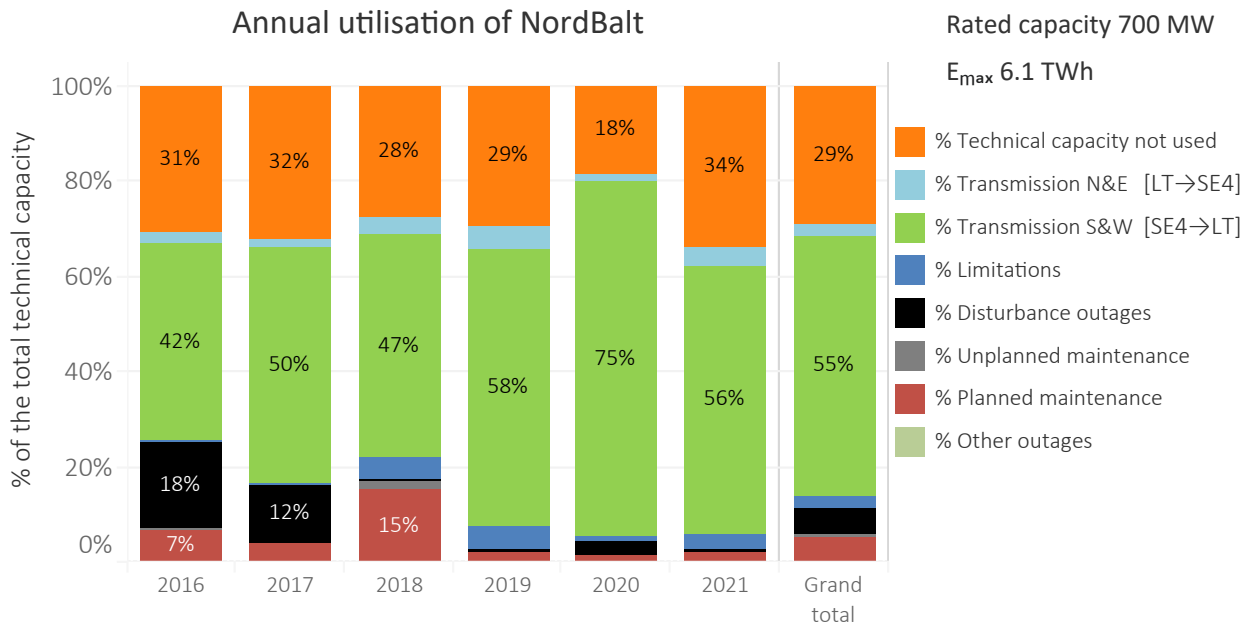

Figure 5.52: Annual utilisation of NordBalt per the utilisation and unavailability categories for the years 2016–2021. The utilisation and unavailability categories are described in more detail in Chapter 3.

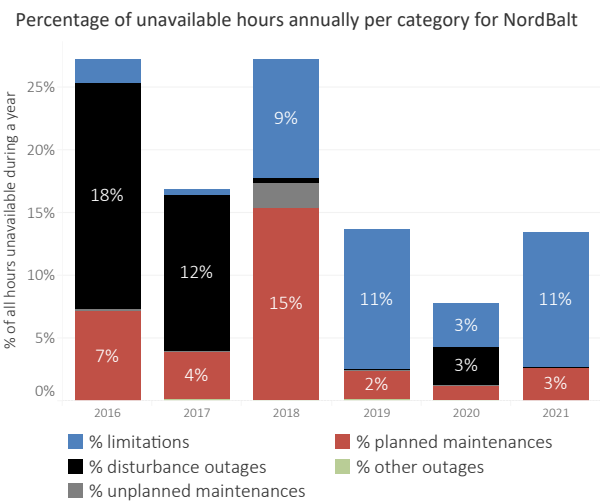

Figure 5.53: Percentage of hours NordBalt has been affected by either a limitation or an outage annually since 2016. The percentage is calculated by counting the number of hours with a limitation or outage and dividing it by the total number of hours in a year. It should be noted that any single hour can be affected by both an outage and a limitation.

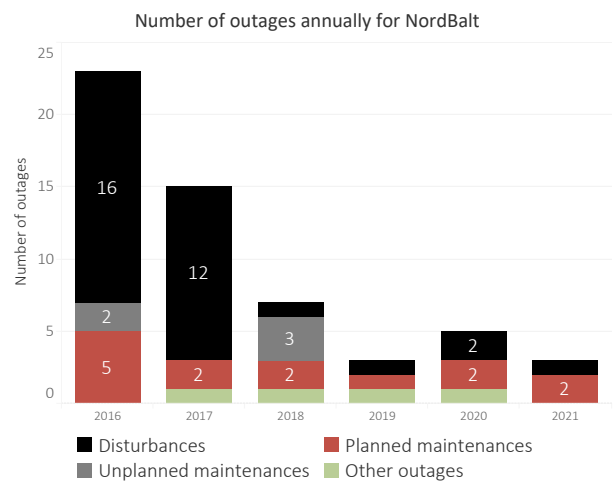

Figure 5.54: The annual number of disturbances, unplanned and planned maintenance outages and other outages for NordBalt for the years 2016–2021.

### 5.3.12 NordLink 1

Figure 5.55 presents the availability and utilisation of NordLink 1 for 2021 and Table 5.15 presents the numerical values behind it. NordLink 1 is the newly commissioned HVDC link located between Tonstad/Ertsmyra in Sirdal municipality in Norway (bidding zone NO2) and Wilster in Schleswig-Holstein in Germany (bidding zone DE). The parallel NordLink 1 and 2 links were commissioned on December 2020 and have each a transmission capacity of 700 MW (1400 MW in total).

In 2021, NordLink 1 had an available technical capacity of 89 %. The technical capacity not used was 46 %. Totally, 2.1 TWh (34 % of the technical capacity) was transmitted south to Germany (NO2→DE) and 0.5 TWh (9 % of the technical capacity) was transmitted north to Norway (DE→NO2).

HVDC links are normally utilised less during the first year due to testing and minor repairs.

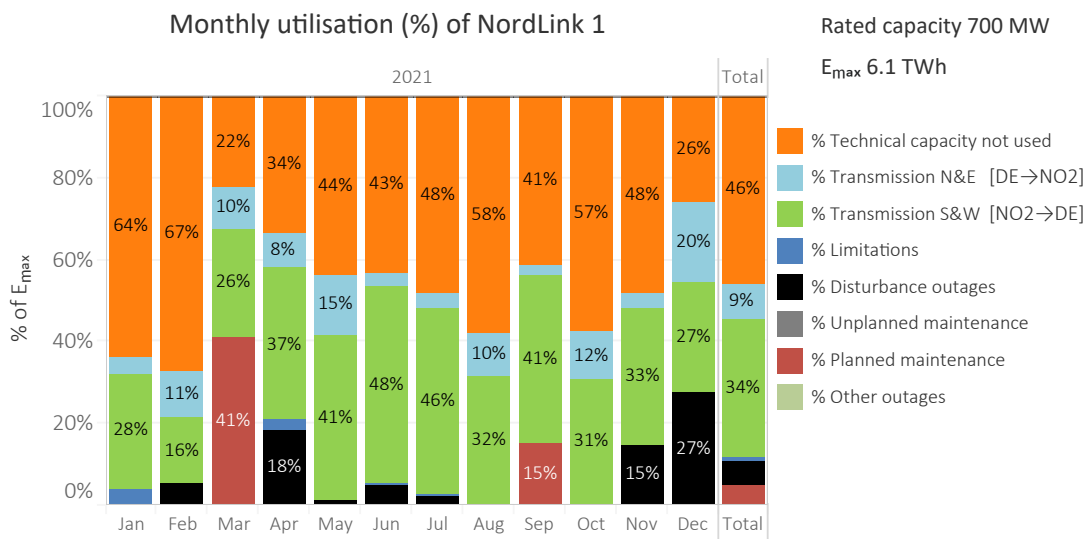

Figure 5.55: Percentage distribution of the availability and utilisation per category according to month for NordLink 1 in 2021. The availability and utilisation categories are defined in detail in Chapter 3.

Table 5.15: Monthly distribution of the technical capacity ( $E_{max}$ ) for NordLink 1 in 2021. Note that losses are not included in the technical capacity ( $E_{max}$ ), as is shown in Figure 3.1.

Monthly utilisation of NordLink 1 (South & West direction NO2→DE)														Total	% total
	Jan	Feb	Mar	Apr	May	Jun	Jul	Aug	Sep	Oct	Nov	Dec			
Technical capacity not used, GWh	331.7	316.8	115.5	169.4	228.1	218.2	250.5	301.3	208.8	299.0	242.4	134.6	2816.4	45.9%	
Transmission N&E, GWh	22.5	53.4	53.3	41.2	75.7	16.0	19.1	54.3	10.7	61.7	19.5	103.4	530.9	8.7%	
Transmission S&W, GWh	146.7	75.7	137.4	187.9	211.0	243.9	237.8	165.2	208.3	160.1	168.3	139.7	2082.1	34.0%	
Limitations, GWh	19.9	-	-	13.5	-	0.1	0.7	-	-	-	-	-	34.2	0.6%	
Disturbance outages, GWh	-	24.5	-	91.6	6.1	25.8	12.7	-	-	-	73.8	143.2	377.5	6.2%	
Unplanned maintenance, GWh	-	-	-	-	-	-	-	-	-	-	-	-	-	-	
Planned maintenance, GWh	-	-	214.6	0.6	-	-	-	-	76.2	-	-	-	291.4	4.8%	
Other outages, GWh	-	-	-	-	-	-	-	-	-	-	-	-	-	-	
Total, GWh	520.8	470.4	520.9	504.1	520.9	504.0	520.8	520.8	504.0	520.8	504.0	520.9	6132.5	100.0%	
Losses SW, GWh	3.9	2.1	3.7	4.9	6.0	6.6	6.2	4.3	6.0	4.4	4.7	3.9	56.8	0.9%	
Losses NE, GWh	0.7	1.7	1.7	1.2	2.2	0.5	0.6	1.6	0.3	1.9	0.6	3.3	16.3	0.3%	

### 5.3.13 NordLink 2

Figure 5.56 presents the availability and utilisation of NordLink 2 for 2021 and Table 5.16 presents the numerical values behind it. NordLink 2 is the newly commissioned HVDC link located between Tonstad/Ertsmyra in Sirdal municipality in Norway (bidding zone NO2) and Wilster in Schleswig-Holstein in Germany (bidding zone DE). The parallel NordLink 1 and 2 links were commissioned on December 2020 and have each a transmission capacity of 700 MW (1400 MW in total).

In 2021, NordLink 2 had an available technical capacity of 92 %. The technical capacity not used was 46 %. Totally, 2.1 TWh (36 % of the technical capacity) was transmitted south to Germany (NO2→DE) and 0.5 TWh (9 % of the technical capacity) was transmitted north to Norway (DE→NO2).

HVDC links are normally utilised less during the first year due to testing and minor repairs.

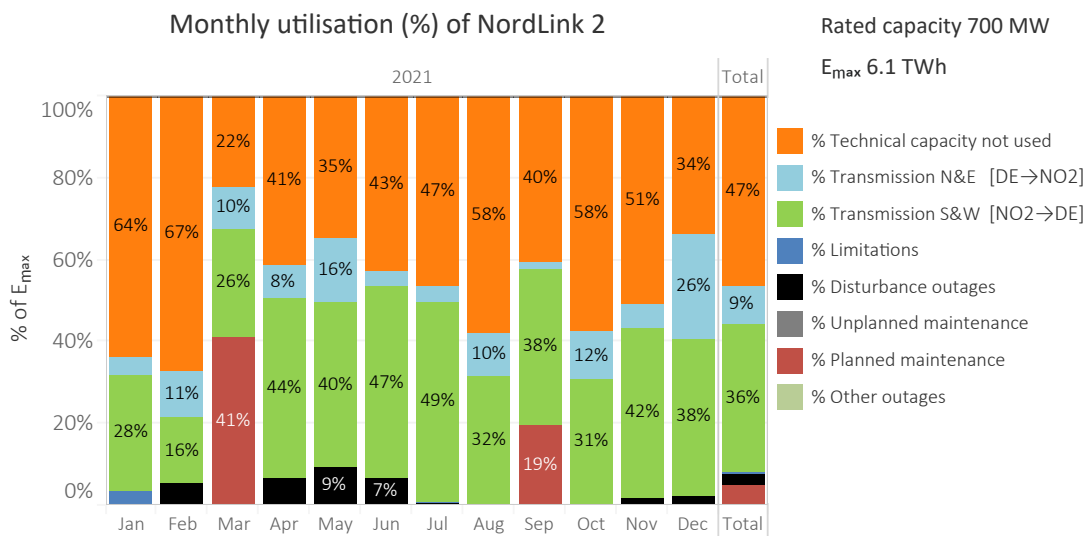

Figure 5.56: Percentage distribution of the availability and utilisation per category according to month for NordLink 2 in 2021. The availability and utilisation categories are defined in detail in Chapter 3.

Table 5.16: Monthly distribution of the technical capacity ( $E_{max}$ ) for NordLink 2 in 2021. Note that losses are not included in the technical capacity ( $E_{max}$ ), as is shown in Figure 3.1.

Monthly utilisation of NordLink 2 (South & West direction NO2→DE)														Total	% total
	Jan	Feb	Mar	Apr	May	Jun	Jul	Aug	Sep	Oct	Nov	Dec			
Technical capacity not used, GWh	332.5	317.2	116.1	208.5	181.2	216.9	242.7	302.1	203.6	299.6	257.3	176.8	2854.5	46.6%	
Transmission N&E, GWh	22.4	53.3	52.7	40.4	80.8	16.0	19.1	54.1	10.7	61.6	28.8	133.1	573.0	9.3%	
Transmission S&W, GWh	146.3	75.4	137.4	220.8	210.1	237.4	254.1	164.6	191.4	159.6	209.6	198.6	2205.2	36.0%	
Limitations, GWh	19.6	-	-	-	-	-	2.3	-	-	-	-	-	21.9	0.4%	
Disturbance outages, GWh	-	24.5	-	33.8	48.6	33.7	2.7	-	-	-	8.3	12.3	164.0	2.7%	
Unplanned maintenance, GWh	-	-	-	-	-	-	-	-	-	-	-	-	-	-	
Planned maintenance, GWh	-	-	214.7	0.6	-	-	-	-	98.2	-	-	-	313.4	5.1%	
Other outages, GWh	-	-	-	-	-	-	-	-	-	-	-	-	-	-	
Total, GWh	520.8	470.4	520.8	504.0	520.8	504.0	520.8	520.8	504.0	520.8	504.0	520.8	6132.1	100.0%	
Losses SW, GWh	4.0	2.1	3.8	6.8	5.9	6.3	6.6	4.3	5.3	4.4	6.8	6.5	62.9	1.0%	
Losses NE, GWh	0.7	1.7	1.6	1.2	2.5	0.5	0.6	1.7	0.3	1.8	1.1	4.7	18.4	0.3%	

### 5.3.14 NorNed

Figure 5.57 presents the availability and utilisation of NorNed for 2021 and Table 5.17 presents the numerical values behind it. NorNed has been in operation since 2008, and is, with a length of 580 km, the longest HVDC link connected to the Nordic power system. In Norway on the south-western coast (bidding zone NO2) it is connected to Feda substation and in Netherlands to Eemshaven (bidding zone APX NL). The transmission capacity of NorNed is 700 MW.

In 2021, NorNed had an available technical capacity of

73 %. The technical capacity not used was 10 %. Totally, 3.5 TWh (57 % of the technical capacity) was transmitted south to Netherlands (NO2→DE) and 0.3 TWh (6 % of the technical capacity) was transmitted north to Norway (DE→NO2).

NorNed had a major cable fault on the Dutch side in mid-January until March. There was also longer annual maintenance in August/September. In December a broken neutral-point isolator in Feda caused a disturbance outage.

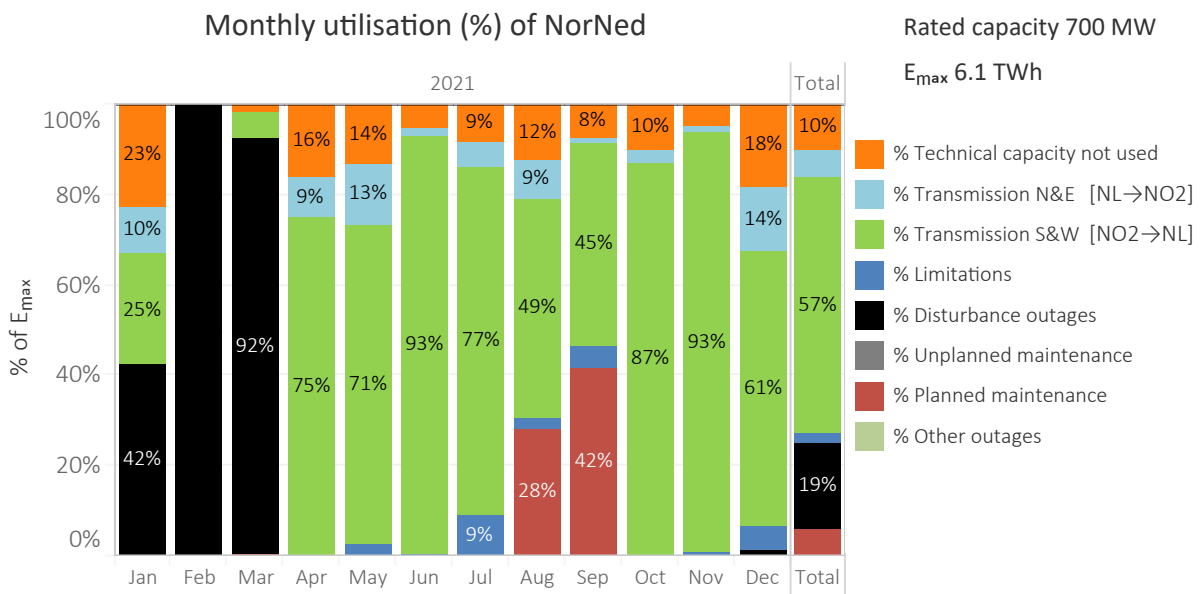

Figure 5.57: Monthly percentage allocation of utilisation by category for NorNed in 2021. The availability and utilisation categories are defined in detail in Chapter 3.

Table 5.17: Monthly allocation of technical capacity (E<sub>max</sub>) for NorNed in 2021. Note that losses are not included in the technical capacity (E<sub>max</sub>), as is shown in Figure 3.1.

Monthly utilisation of NorNed (South & West direction NO2→NL)														Total	% total
	Jan	Feb	Mar	Apr	May	Jun	Jul	Aug	Sep	Oct	Nov	Dec			
Technical capacity not used, GWh	117.6	-	9.2	81.1	70.8	26.3	45.1	64.3	38.2	52.6	25.6	95.5	626.4	10.2%	
Transmission N&E, GWh	53.6	-	-	45.0	68.4	9.1	27.1	44.6	4.9	15.9	6.0	75.1	349.7	5.7%	
Transmission S&W, GWh	129.4	-	30.4	379.4	369.3	467.4	401.8	254.2	227.8	453.8	470.2	315.5	3499.1	57.0%	
Limitations, GWh	-	-	-	-	13.3	2.3	47.1	11.7	23.1	-	3.7	29.2	130.5	2.1%	
Disturbance outages, GWh	220.5	470.4	478.1	-	-	-	-	-	-	0.6	-	5.9	1175.5	19.1%	
Unplanned maintenance, GWh	-	-	-	-	-	-	-	-	-	-	-	-	-	-	
Planned maintenance, GWh	-	-	3.2	-	-	-	-	146.3	210.6	-	-	-	360.1	5.9%	
Other outages, GWh	-	-	-	-	-	-	-	-	-	-	-	-	-	-	
Total, GWh	521.1	470.4	520.9	505.5	521.8	505.1	521.0	521.1	504.7	523.0	505.6	521.2	6141.4	100.0%	
Losses SW, GWh	4.4	-	1.2	14.5	14.2	18.2	14.0	9.5	8.2	17.7	18.4	11.2	131.3	2.1%	
Losses NE, GWh	2.0	-	-	1.7	2.5	0.4	1.0	1.7	0.2	0.6	0.2	2.9	13.3	0.2%	



Figure 5.58 presents the annual utilisation of NorNed per utilisation and unavailability category for the years 2012–2021.

turbance outage, an unplanned or planned maintenance outage or other outage annually during the years 2012–2021. Figure 5.60 presents the annual number of disturbance outages, unplanned and planned maintenances and other outages during the years 2012–2021.

Figure 5.59 presents the percentage of hours of a year NorNed has been affected by either a limitation, a dis-

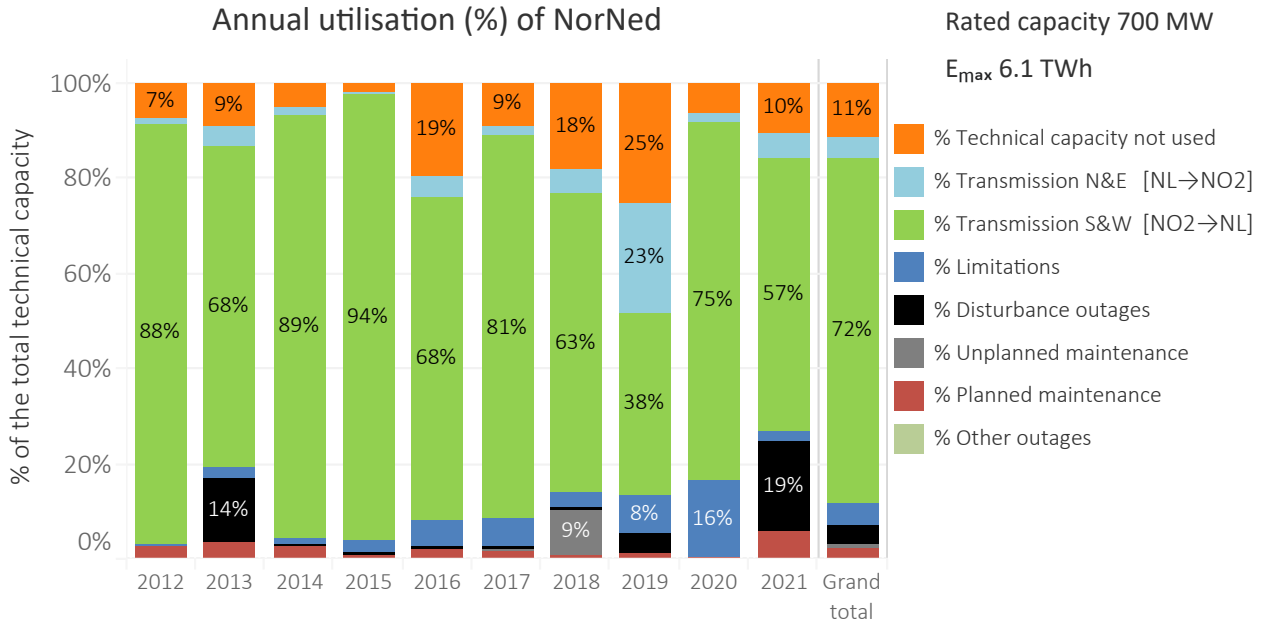

Figure 5.58: Annual utilisation of NorNed per the utilisation and unavailability categories for the years 2012–2021. The utilisation and unavailability categories are described in more detail in Chapter 3.

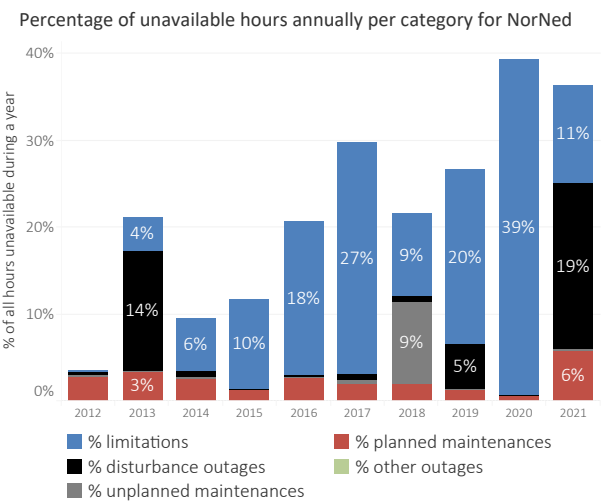

Figure 5.59: Percentage of hours NorNed has been affected by either a limitation or an outage annually since 2012. The percentage is calculated by counting the number of hours with a limitation or outage and dividing it by the total number of hours in a year. It should be noted that any single hour can be affected by both an outage and a limitation.

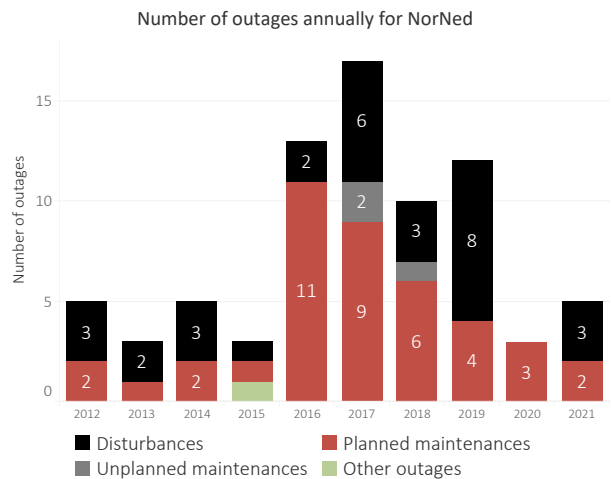

Figure 5.60: The annual number of disturbances, unplanned and planned maintenance outages and other outages for NorNed for the years 2012–2021.

### 5.3.15 Skagerrak 1

Figure 5.61 presents the availability and utilisation of Skagerrak 1 for 2021 and Table 5.18 presents the numerical values behind it. Skagerrak 1 and Skagerrak 2 have been in operation since 1976 and are the oldest HVDC links in operation in the Nordic countries. In Norway, the links are connected to Kristiansand on the southern coast (bidding zone NO2) and in Denmark to Tjele (bidding zone DK1), 15 km east of the town of Viborg in the northern part of Jutland. The transmission capacity is 236 MW at the receiving end.

In 2021, Skagerrak 1 had an available technical capacity of 94 %. The technical capacity not used was 39 %. Totally, 0.8 TWh (41 % of the technical capacity) was transmitted south to Denmark (NO2→DK1) and 0.3 TWh (14 %

of the technical capacity) was transmitted north to Norway (DK1→NO2).

Annual maintenance for Skagerrak 1 lasted 5 days. There were two minor disturbance outages.

Skagerrak 1, 2, 3 and 4 have been limited due to “careful operation” since the Skagerrak 4 cable faults in December 2019. In 2021, the south direction continued to be prioritised. The careful operation of the Skagerrak links has impacted each of the links differently based on the transmission direction and which links are in operation. For example, if all links are available and the transmission goes from Denmark to Norway (i.e., north), Skagerrak 2 is limited to 0 MW and Skagerrak 3 is limited to 200 MW to maintain acceptable electrode current levels.

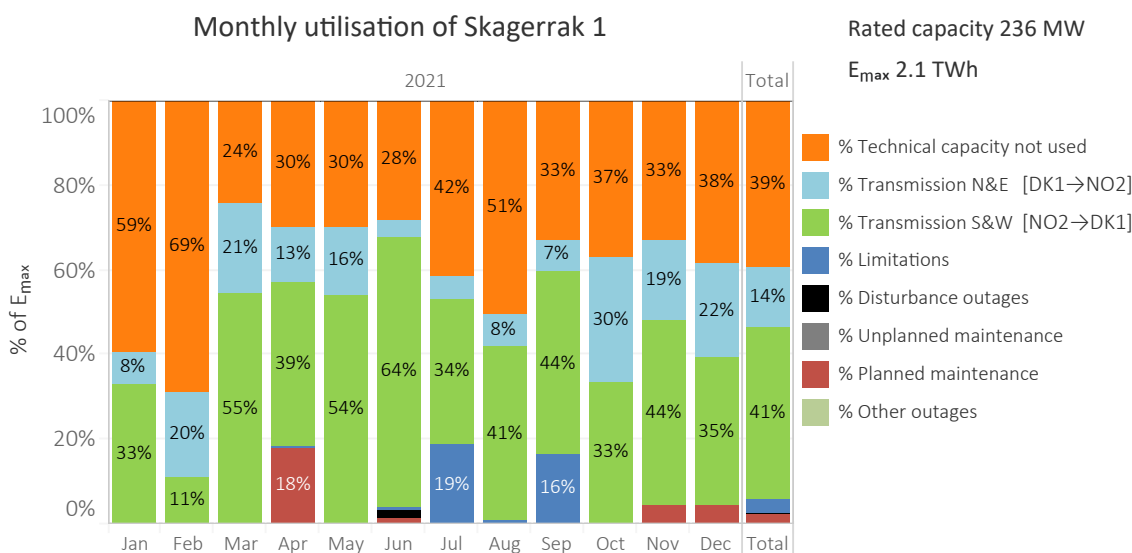

Figure 5.61: Monthly percentage allocation of utilisation by category for Skagerrak 1 in 2021. The availability and utilisation categories are defined in detail in Chapter 3.

Table 5.18: Monthly allocation of technical capacity (E<sub>max</sub>) for Skagerrak 1 in 2021. Note that losses are not included in the technical capacity (E<sub>max</sub>), as is shown in Figure 3.1.

	Jan	Feb	Mar	Apr	May	Jun	Jul	Aug	Sep	Oct	Nov	Dec	Total	% total
Technical capacity not used, GWh	104.3	109.1	42.0	50.9	52.8	48.0	73.0	88.8	56.3	64.8	55.9	67.4	813.3	39.3%
Transmission N&E, GWh	13.2	31.9	37.7	21.8	27.8	6.7	9.5	13.4	11.6	52.2	32.2	39.1	297.2	14.4%
Transmission S&W, GWh	58.1	17.5	96.0	66.0	95.0	108.4	60.0	72.0	74.0	58.7	74.1	61.1	840.9	40.7%
Limitations, GWh	-	-	-	0.2	-	2.0	33.1	1.3	28.0	-	-	-	64.6	3.1%
Disturbance outages, GWh	-	0.1	-	-	-	2.7	-	-	-	-	-	-	2.8	0.1%
Unplanned maintenance, GWh	-	-	-	-	-	-	-	-	-	-	-	-	-	-
Planned maintenance, GWh	-	-	-	31.1	-	2.3	-	-	-	-	7.8	7.9	49.2	2.4%
Other outages, GWh	-	-	-	-	-	-	-	-	-	-	-	-	-	-
Total, GWh	175.6	158.6	175.6	170.0	175.6	170.0	175.6	175.6	170.0	175.8	170.0	175.6	2067.9	100.0%
Losses SW, GWh	2.8	0.9	4.8	3.4	5.0	5.3	2.5	3.5	3.2	2.9	3.4	2.8	40.4	2.0%
Losses NE, GWh	0.5	1.2	1.6	0.9	1.2	0.3	0.4	0.6	0.5	2.3	1.4	1.6	12.5	0.6%

Figure 5.62 presents the annual utilisation of Skagerrak 1 per utilisation and unavailability category for the years 2012–2021.

Figure 5.63 presents the percentage of hours of a year Skagerrak 1 has been affected by either a limitation, a dis-

turbance outage, an unplanned or planned maintenance outage or other outage annually during the years 2012–2021. Figure 5.64 presents the annual number of disturbance outages, unplanned and planned maintenances and other outages during the years 2012–2021.

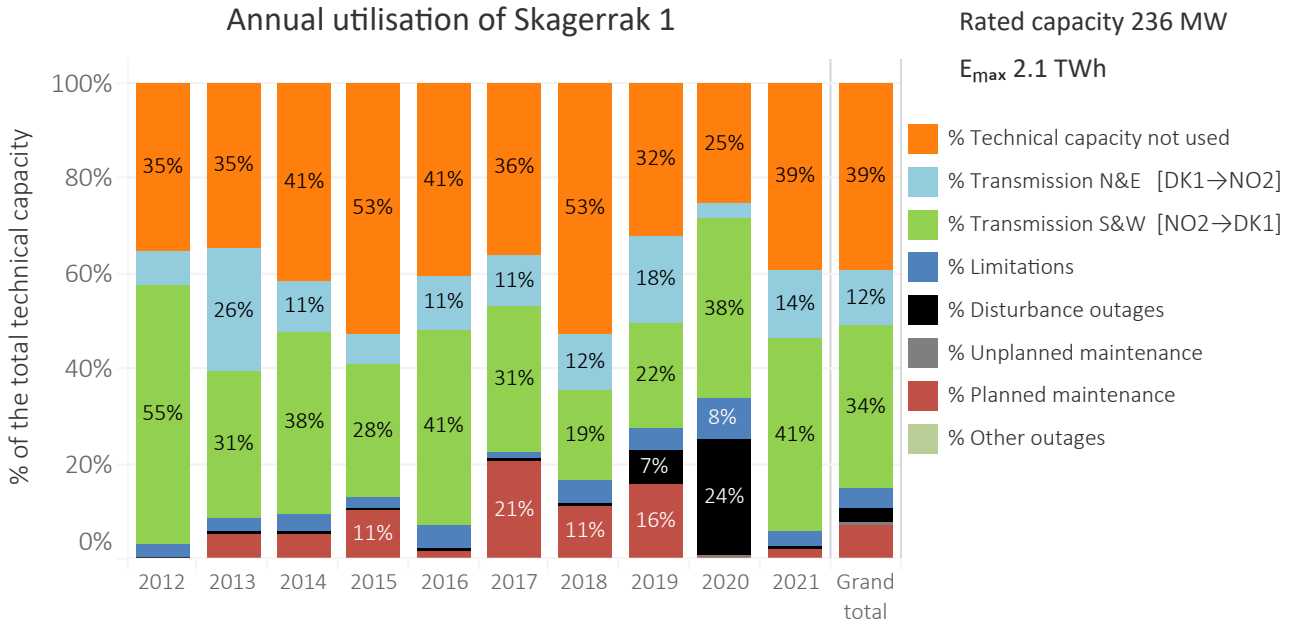

Figure 5.62: Annual utilisation of Skagerrak 1 per the utilisation and unavailability categories for the years 2012–2021. The utilisation and unavailability categories are described in more detail in Chapter 3.

Percentage of unavailable hours annually per category for Skagerrak 1

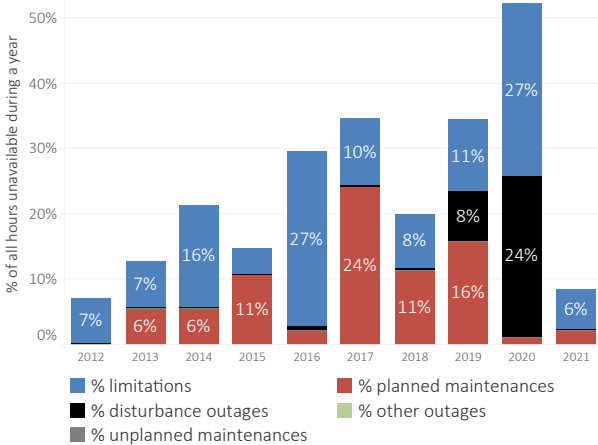

Figure 5.63: Percentage of hours Skagerrak 1 has been affected by either a limitation or an outage annually since 2012. The percentage is calculated by counting the number of hours with a limitation or outage and dividing it by the total number of hours in a year. It should be noted that any single hour can be affected by both an outage and a limitation.

Number of outages annually for Skagerrak 1

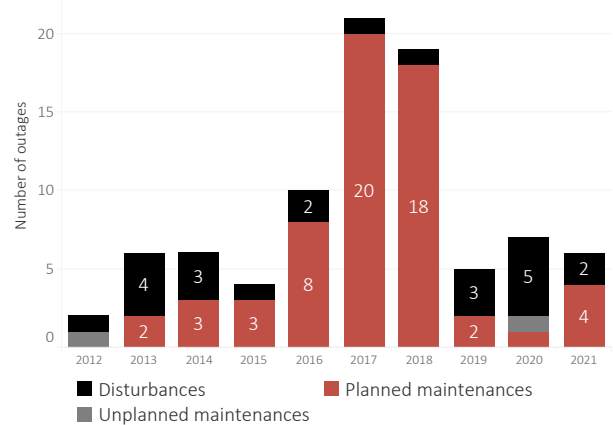

Figure 5.64: The annual number of disturbances, unplanned and planned maintenance outages and other outages for Skagerrak 1 for the years 2012–2021. Skagerrak 1 had no other outages during the years 2012–2021.

### 5.3.16 Skagerrak 2

Figure 5.65 presents the availability and utilisation of Skagerrak 2 for 2021 and Table 5.19 presents the numerical values behind it. Skagerrak 1 and Skagerrak 2 have been in operation since 1976 and are the oldest HVDC links in operation in the Nordic countries. In Norway, the links are connected to Kristiansand on the southern coast (bidding zone NO2) and in Denmark to Tjele (bidding zone DK1), 15 km east of the town of Viborg in the northern part of Jutland. The transmission capacity of Skagerrak 2 is 236 MW at the receiving end.

In 2021, Skagerrak 2 had an available technical capacity of 75 %. The technical capacity not used was 33 %. Totally, 0.8 TWh (40 % of the technical capacity) was transmitted south to Denmark (NO2→DK1) and <0.1 TWh (1 %

of the technical capacity) was transmitted north to Norway (DK1→NO2).

Annual maintenance for Skagerrak 2 lasted 5 days in April. There were three minor disturbance outages.

Skagerrak 1, 2, 3 and 4 have been limited due to “careful operation” since the Skagerrak 4 cable faults in December 2019. In 2021, the south direction continued to be prioritised. The careful operation of the Skagerrak links has impacted each of the links differently based on the transmission direction and which links are in operation. For example, if all links are available and the transmission goes from Denmark to Norway (i.e., north) Skagerrak 2 is limited to 0 MW and Skagerrak 3 is limited to 200 MW to maintain acceptable electrode current levels.

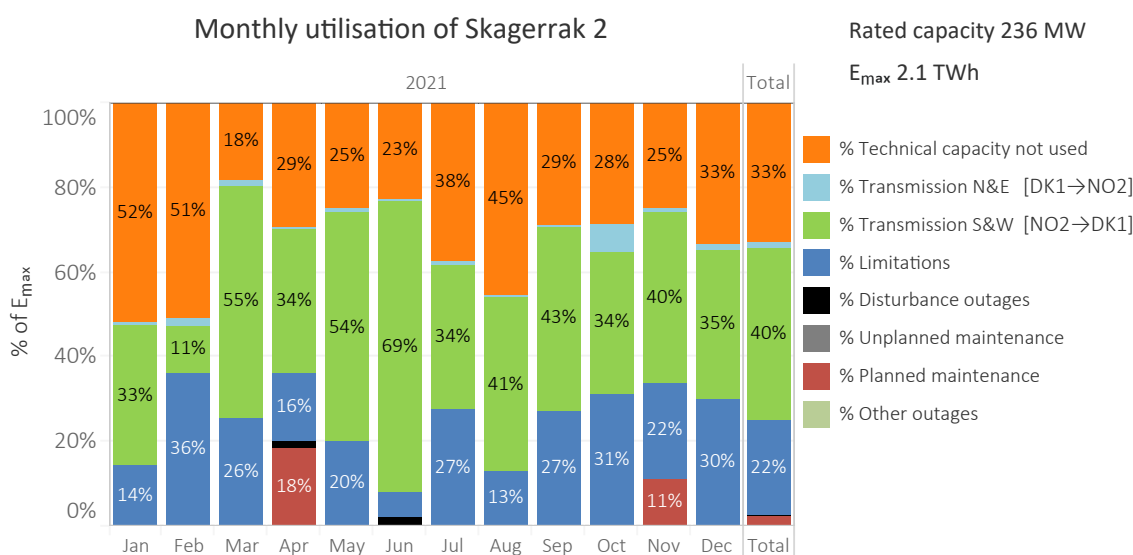

Figure 5.65: Monthly percentage allocation of utilisation by category for Skagerrak 2 in 2021. The availability and utilisation categories are defined in detail in Chapter 3.

Table 5.19: Monthly allocation of technical capacity (E<sub>max</sub>) for Skagerrak 2 in 2021. Note that losses are not included in the technical capacity (E<sub>max</sub>), as is shown in Figure 3.1.

	Jan	Feb	Mar	Apr	May	Jun	Jul	Aug	Sep	Oct	Nov	Dec	Total	% total
Technical capacity not used, GWh	91.2	80.9	32.4	49.7	43.5	38.6	66.2	79.8	49.3	49.9	42.4	58.6	682.6	33.0%
Transmission N&E, GWh	1.1	2.6	2.3	1.3	1.7	0.5	1.2	1.0	0.8	11.7	1.9	2.6	28.7	1.4%
Transmission S&W, GWh	58.2	17.5	95.9	57.4	95.3	117.5	59.9	72.0	73.8	58.9	68.2	61.5	836.2	40.4%
Limitations, GWh	25.1	57.6	44.9	27.5	35.1	9.9	48.2	22.8	46.0	55.1	38.2	52.9	463.3	22.4%
Disturbance outages, GWh	-	-	-	3.3	-	3.5	-	-	-	-	-	-	6.8	0.3%
Unplanned maintenance, GWh	-	-	-	-	-	-	-	-	-	-	-	-	-	-
Planned maintenance, GWh	-	-	-	30.8	-	-	-	-	-	-	19.2	-	50.1	2.4%
Other outages, GWh	-	-	-	-	-	-	-	-	-	-	-	-	-	-
Total, GWh	175.6	158.6	175.6	170.0	175.6	170.0	175.6	175.6	169.9	175.6	169.9	175.6	2067.6	100.0%
Losses SW, GWh	2.8	0.9	4.7	2.9	4.7	6.0	2.7	3.7	3.5	2.9	3.4	3.1	41.2	2.0%
Losses NE, GWh	0.1	0.2	0.2	0.1	0.2	-0.1	0.1	0.1	0.1	0.7	0.2	0.2	2.2	0.1%

Figure 5.66 presents the annual utilisation of Skagerrak 2 per utilisation and unavailability category for the years 2012–2021.

Figure 5.67 presents the percentage of hours of a year Skagerrak 2 has been affected by either a limitation, a disturbance outage, an unplanned or planned maintenance

outage or other outage annually during the years 2012–2021. Figure 5.68 presents the annual number of disturbance outages, unplanned and planned maintenances and other outages during the years 2012–2021.

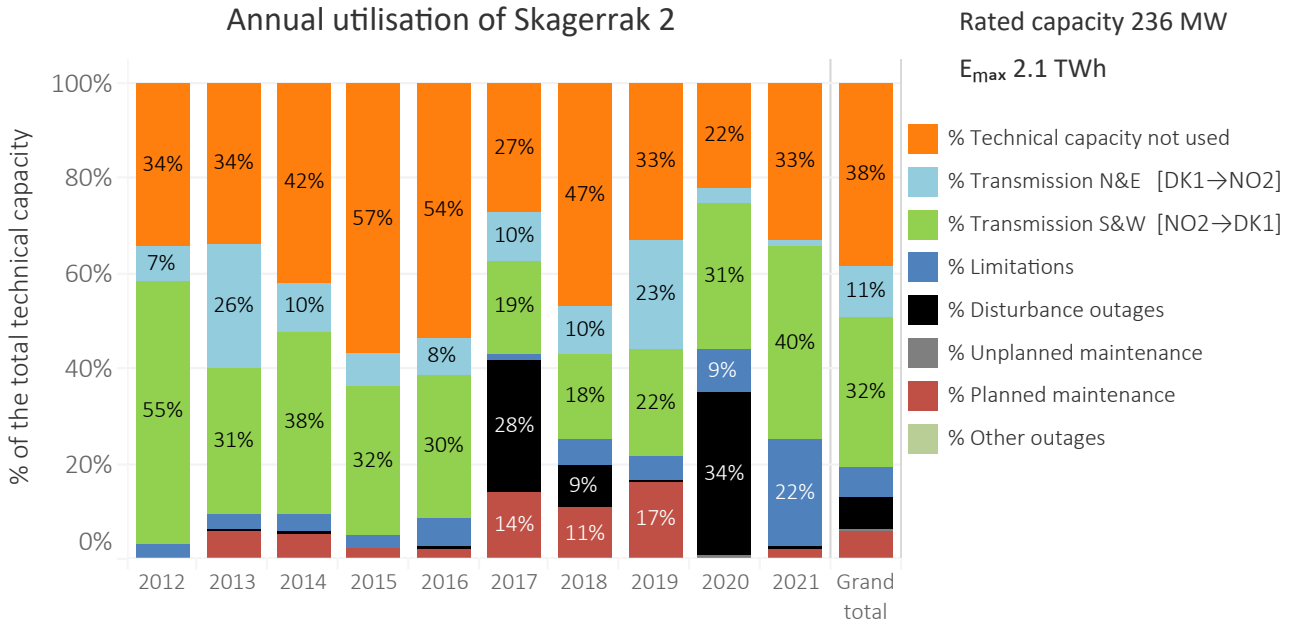

Figure 5.66: Annual utilisation of Skagerrak 2 per the utilisation and unavailability categories for the years 2012–2021. The utilisation and unavailability categories are described in more detail in Chapter 3.

Percentage of unavailable hours annually per category for Skagerrak 2

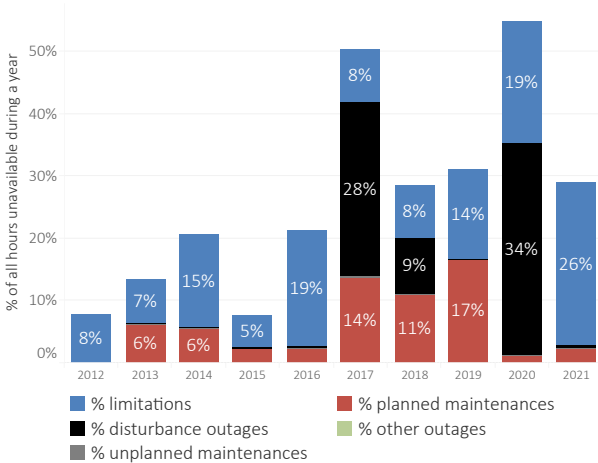

Figure 5.67: Percentage of hours Skagerrak 2 has been affected by either a limitation or an outage annually since 2012. The percentage is calculated by counting the number of hours with a limitation or outage and dividing it by the total number of hours in a year. It should be noted that any single hour can be affected by both an outage and a limitation.

Number of outages annually for Skagerrak 2

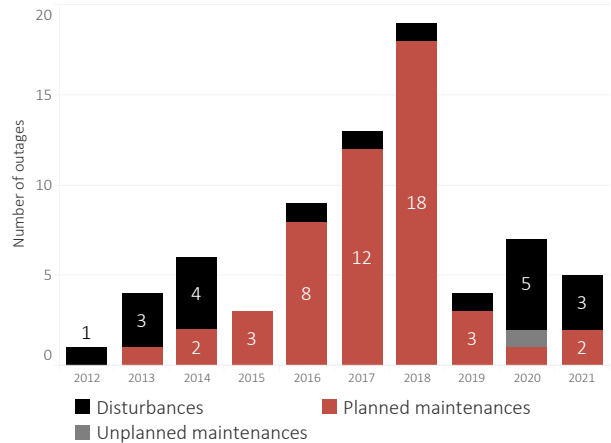

Figure 5.68: The annual number of disturbances, unplanned and planned maintenance outages and other outages for Skagerrak 2 for the years 2012–2021. Skagerrak 2 had no other outages during the years 2012–2021.

### 5.3.17 Skagerrak 3

Figure 5.69 presents the availability and utilisation of Skagerrak 3 for 2021 and Table 5.20 presents the numerical values behind it. Skagerrak 3 has been in operation since 1993. In Norway, it is connected to Kristiansand (bidding zone NO2) and in Denmark to Tjele (bidding zone DK1). The transmission capacity of Skagerrak 3 is 478 MW at the receiving end.

In 2021, Skagerrak 3 had an available technical capacity of 89 %. The technical capacity not used was 19 %. Totally, 2.6 TWh (61 % of the technical capacity) was transmitted south to Denmark (NO2→DK1) and 0.4 TWh (9 % of the technical capacity) was transmitted north to Norway (DK1→NO2).

Annual maintenance for Skagerrak 3 lasted 4 days. There were no disturbance outages, and only one other planned maintenance were Skagerrak 3 had to be disconnected due to repair of a fault on a voltage transformer.

Skagerrak 1, 2, 3 and 4 have been limited due to “careful operation” since the Skagerrak 4 cable faults in December 2019. In 2021, the south direction continued to be prioritised. The careful operation of the Skagerrak links has impacted each of the links differently based on the transmission direction and which links are in operation. For example, if all links are available and the transmission goes from Denmark to Norway (i.e., north), Skagerrak 2 is limited to 0 MW and Skagerrak 3 is limited to 200 MW to maintain acceptable electrode current levels.

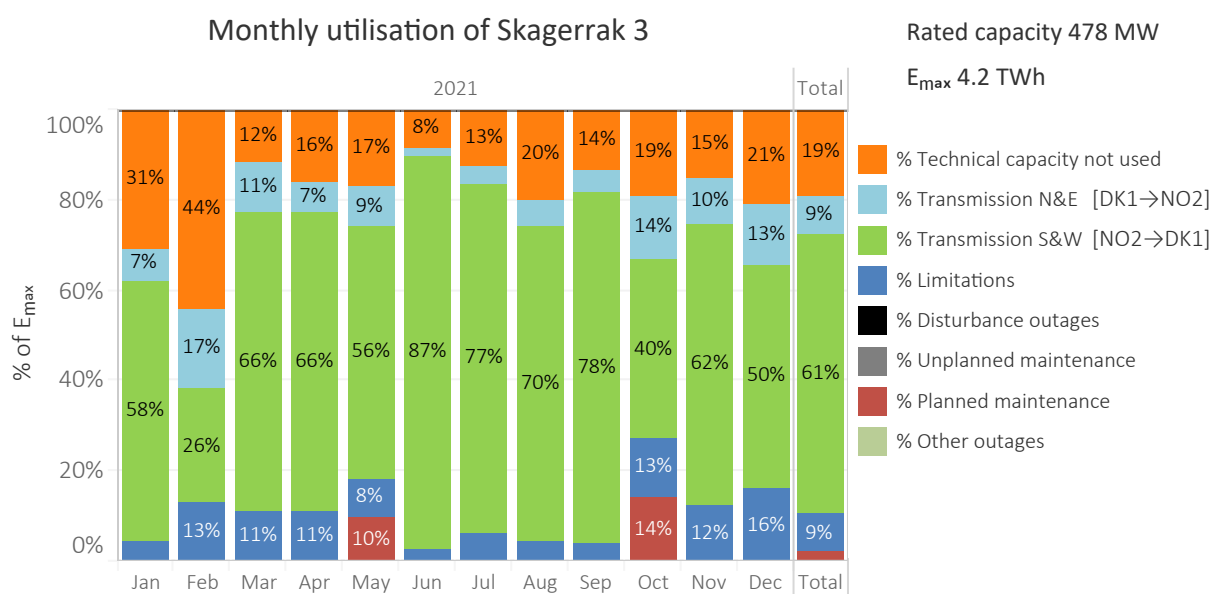

Figure 5.69: Monthly percentage allocation of utilisation by category for Skagerrak 3 in 2021. The availability and utilisation categories are defined in detail in Chapter 3.

Table 5.20: Monthly allocation of technical capacity (E<sub>max</sub>) for Skagerrak 3 in 2021. Note that losses are not included in the technical capacity (E<sub>max</sub>), as is shown in Figure 3.1.

	Jan	Feb	Mar	Apr	May	Jun	Jul	Aug	Sep	Oct	Nov	Dec	Total	% total
Technical capacity not used, GWh	110.6	142.6	41.3	55.9	60.0	28.6	45.4	71.9	46.9	68.5	52.9	75.5	800.0	19.0%
Transmission N&E, GWh	24.2	55.1	39.5	23.0	32.0	7.0	14.1	20.7	15.7	48.6	35.9	47.3	363.0	8.6%
Transmission S&W, GWh	205.8	82.9	235.9	228.4	199.8	300.4	275.4	248.1	268.4	142.3	214.4	176.4	2578.2	61.4%
Limitations, GWh	16.3	41.1	40.6	38.2	29.3	9.8	22.3	15.8	13.7	46.3	42.6	56.8	372.6	8.9%
Disturbance outages, GWh	-	-	-	-	-	-	-	-	-	-	-	-	-	-
Unplanned maintenance., GWh	-	-	-	-	-	-	-	-	-	-	-	-	-	-
Planned maintenance, GWh	-	-	-	-	35.8	-	-	-	-	50.3	-	-	86.1	2.1%
Other outages, GWh	-	-	-	-	-	-	-	-	-	-	-	-	-	-
Total, GWh	356.9	321.6	357.3	345.5	356.9	345.7	357.1	356.6	344.7	355.9	345.7	356.0	4199.8	100.0%
Losses SW, GWh	5.0	1.9	6.0	5.6	5.1	8.0	7.1	6.4	7.0	3.7	5.4	4.4	65.6	1.6%
Losses NE, GWh	0.6	1.4	1.0	0.6	0.8	0.2	0.4	0.6	0.4	1.3	0.9	1.2	9.5	0.2%

Figure 5.70 presents the annual utilisation of Skagerrak 3 per utilisation and unavailability category for the years 2012–2021.

Figure 5.71 presents the percentage of hours of a year Skagerrak 3 has been affected by either a limitation, a dis-

turbance outage, an unplanned or planned maintenance outage or other outage annually during the years 2012–2021. Figure 5.72 presents the annual number of disturbance outages, unplanned and planned maintenances and other outages during the years 2012–2021.

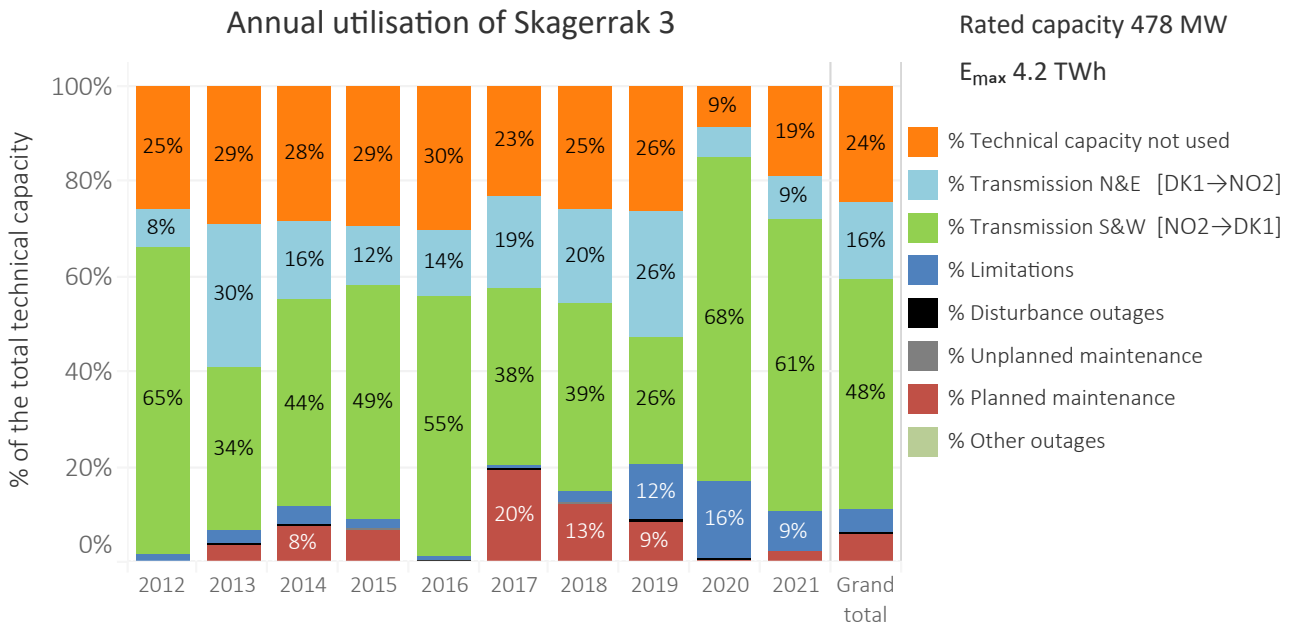

Figure 5.70: Annual utilisation of Skagerrak 3 per the utilisation and unavailability categories for the years 2012–2021. The utilisation and unavailability categories are described in more detail in Chapter 3.

Percentage of unavailable hours annually per category for Skagerrak 3

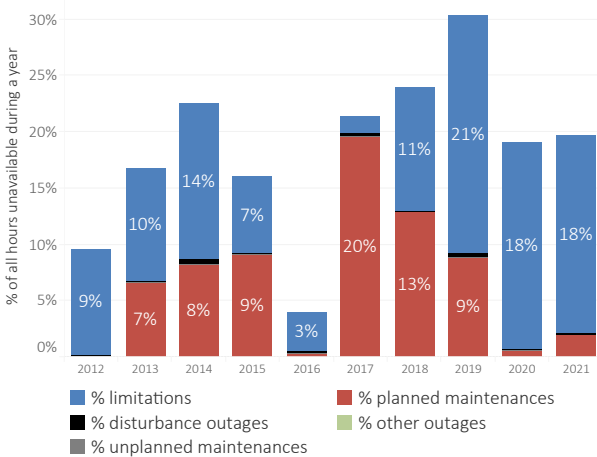

Figure 5.71: Percentage of hours Skagerrak 3 has been affected by either a limitation or an outage annually since 2012. The percentage is calculated by counting the number of hours with a limitation or outage and dividing it by the total number of hours in a year. It should be noted that any single hour can be affected by both an outage and a limitation.

Number of outages annually for Skagerrak 3

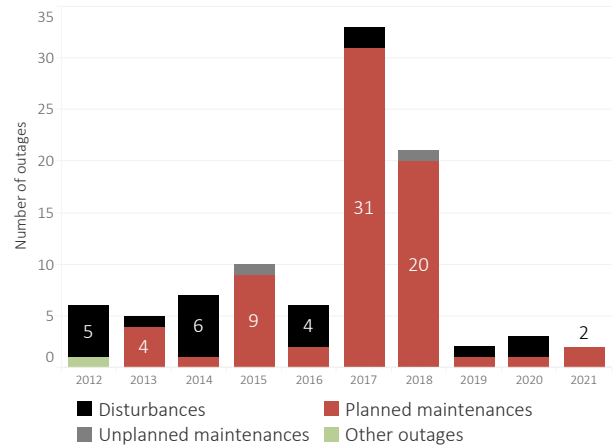

Figure 5.72: The annual number of disturbances, unplanned and planned maintenance outages and other outages for Skagerrak 3 for the years 2012–2021.

### 5.3.18 Skagerrak 4

Figure 5.73 presents the availability and utilisation of Skagerrak 4 for 2021 and Table 5.21 presents the numerical values behind it. Skagerrak 4 has been in commercial operation since 29 December 2014. In Norway, it is connected to Kristiansand (bidding zone NO2) and in Denmark to Tjele (bidding zone DK1). The transmission capacity is 682 MW at the receiving end.

In 2021, Skagerrak 4 had an available technical capacity of 97 %. The technical capacity not used was 27 %. Totally, 2.6 TWh (61 % of the technical capacity) was transmitted south to Denmark (NO2→DK1) and 0.4 TWh (9 % of the technical capacity) was transmitted north to Norway (DK1→NO2).

There were no annual maintenance for Skagerrak 4 in 2021. There were one minor planned maintenance outage and two minor disturbance outages.

Skagerrak 1, 2, 3 and 4 have been limited due to “careful operation” since the Skagerrak 4 cable faults in December 2019. In 2021, the south direction continued to be prioritised. The careful operation of the Skagerrak links has impacted each of the links differently based on the transmission direction and which links are in operation. For example, if all links are available and the transmission goes from Denmark to Norway (i.e., north), Skagerrak 2 is limited to 0 MW and Skagerrak 3 is limited to 200 MW to maintain acceptable electrode current levels.

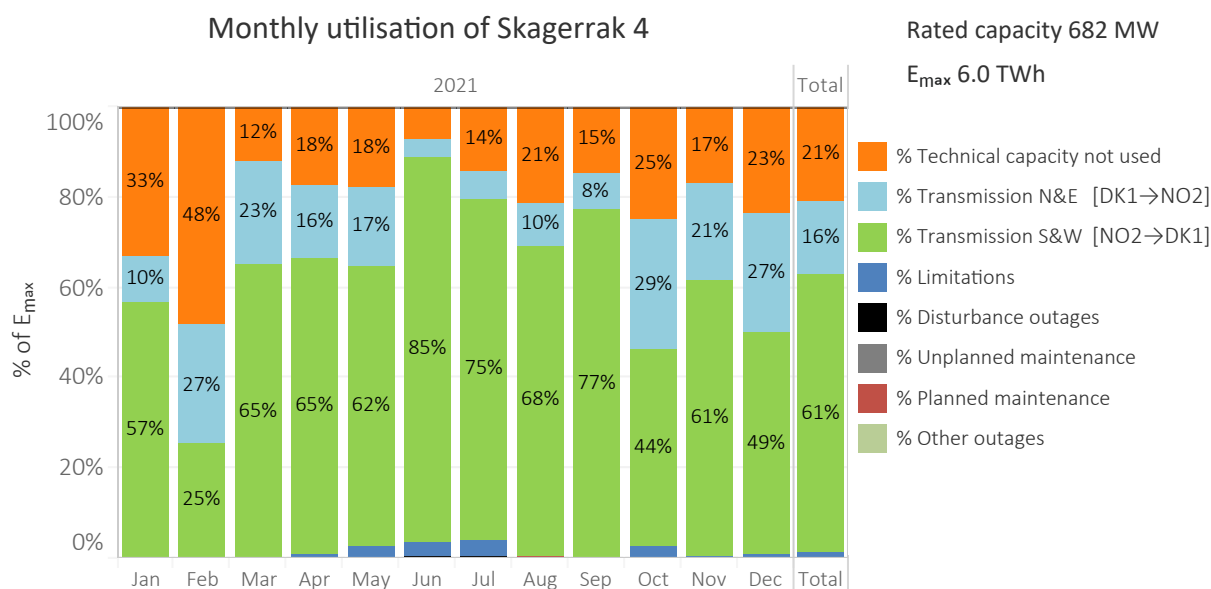

Figure 5.73: Monthly percentage allocation of utilisation by category for Skagerrak 4 in 2021. The availability and utilisation categories are defined in detail in Chapter 3.

Table 5.21: Monthly allocation of technical capacity (E<sub>max</sub>) for Skagerrak 4 in 2021. Note that losses are not included in the technical capacity (E<sub>max</sub>), as is shown in Figure 3.1.

	Jan	Feb	Mar	Apr	May	Jun	Jul	Aug	Sep	Oct	Nov	Dec	Total	% total
Technical capacity not used, GWh	167.3	220.2	62.1	86.4	91.1	34.4	72.4	109.0	73.2	125.8	83.5	119.2	1244.6	20.8%
Transmission N&E, GWh	53.0	122.0	114.4	78.4	86.9	20.1	32.1	48.3	39.0	145.2	104.6	134.7	978.8	16.4%
Transmission S&W, GWh	287.1	116.1	331.0	320.8	315.0	418.6	382.2	346.9	378.8	222.9	300.9	249.1	3669.2	61.4%
Limitations, GWh	-	-	-	5.4	14.4	15.0	18.7	-	-	13.5	2.4	4.4	73.9	1.2%
Disturbance outages, GWh	-	-	-	-	-	3.0	1.9	-	-	-	-	-	4.9	0.1%
Unplanned maintenance, GWh	-	-	-	-	-	-	-	-	-	-	-	-	-	-
Planned maintenance, GWh	-	-	-	-	-	-	-	3.4	-	-	-	-	3.4	0.1%
Other outages, GWh	-	-	-	-	-	-	-	-	-	-	-	-	-	-
Total, GWh	507.4	458.3	507.4	491.0	507.4	491.0	507.4	507.5	491.0	507.4	491.4	507.4	5974.8	100.0%
Losses SW, GWh	5.6	2.3	6.7	6.5	6.5	8.4	7.6	7.2	7.8	4.7	6.1	5.0	74.4	1.2%
Losses NE, GWh	1.5	3.3	3.2	2.2	2.5	0.6	0.9	1.4	1.1	4.1	2.9	3.7	27.4	0.5%



Figure 5.74 presents the annual utilisation of Skagerrak 4 per utilisation and unavailability category for the years 2015–2021.

Figure 5.75 presents the percentage of hours of a year Skagerrak 4 has been affected by either a limitation, a dis-

turbance outage, an unplanned or planned maintenance outage or other outage annually during the years 2015–2021. Figure 5.76 presents the annual number of disturbance outages, unplanned and planned maintenances and other outages during the years 2015–2021.

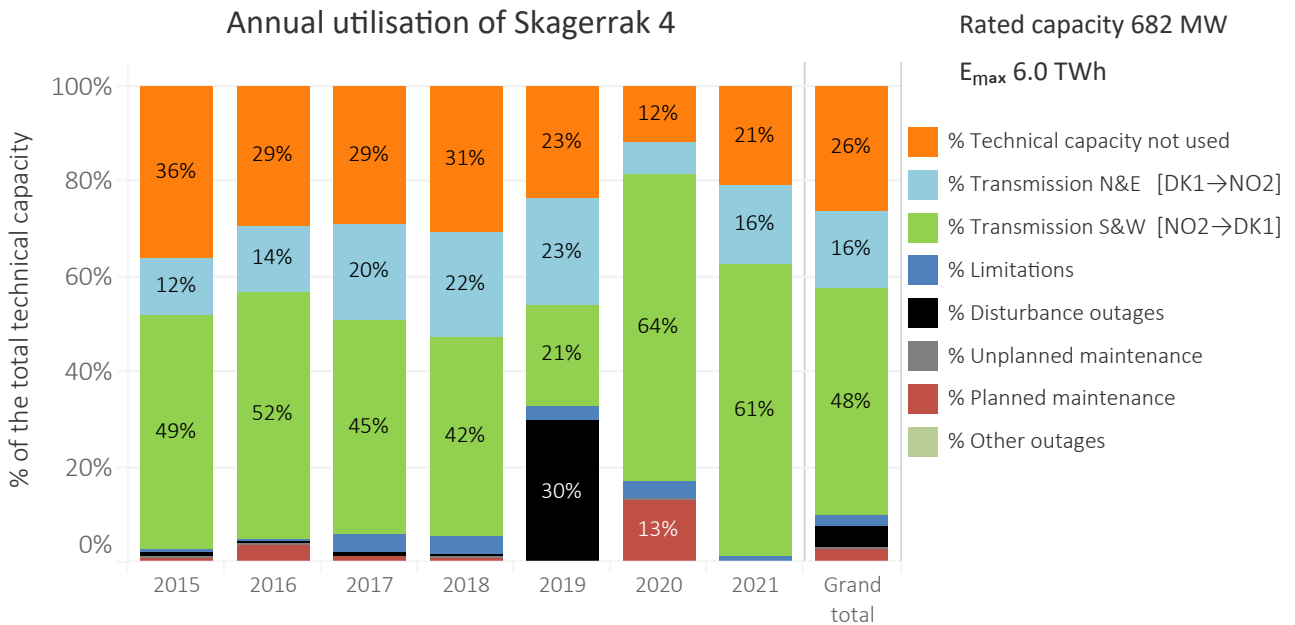

Figure 5.74: Annual utilisation of Skagerrak 4 per the utilisation and unavailability categories for the years 2015–2021. The utilisation and unavailability categories are described in more detail in Chapter 3.

Percentage of unavailable hours annually per category for Skagerrak 4

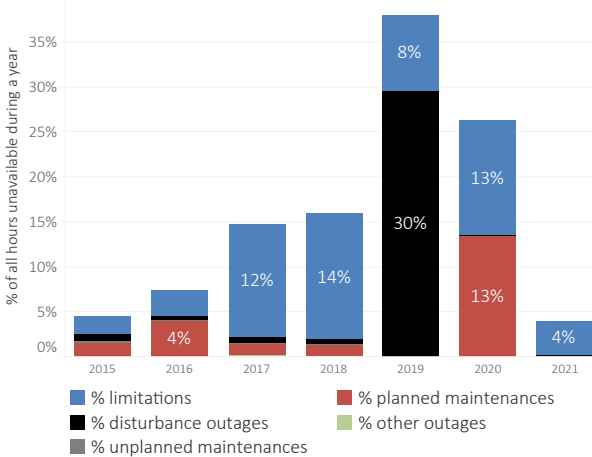

Figure 5.75: Percentage of hours Skagerrak 4 has been affected by either a limitation or an outage annually since 2015. The percentage is calculated by counting the number of hours with a limitation or outage and dividing it by the total number of hours in a year. It should be noted that any single hour can be affected by both an outage and a limitation.

Number of outages annually for Skagerrak 4

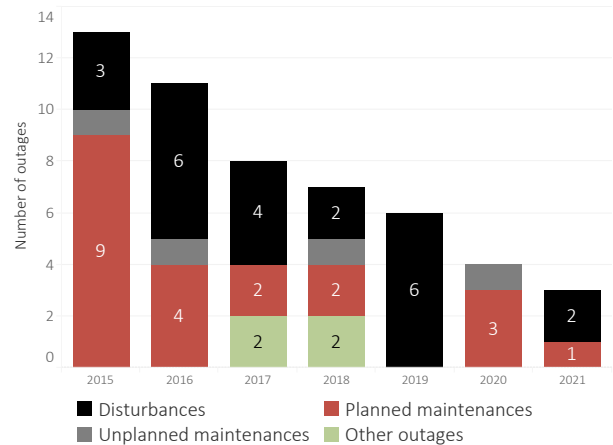

Figure 5.76: The annual number of disturbances, unplanned and planned maintenance outages and other outages for Skagerrak 4 for the years 2015–2021.

### 5.3.19 Storebaelt

Figure 5.77 presents the availability and utilisation of Storebaelt for 2021 and Table 5.22 presents the numerical values behind it. Storebaelt has been in operation since 2010. It connects the western part of the Danish system, which belongs to the Continental European synchronous system (Jutland and the island of Fynen), with the eastern part, belonging to the Nordic synchronous system (Zealand). The link is connected to Fraugde on Fynen (bidding zone DK1) and to Herslev on Zealand (bidding zone DK2). The transmission capacity is 600 MW.

In 2021, Storebaelt had an available technical capacity of 99 %. The technical capacity not used was 41 %. Totally, 2.4 TWh (46 % of the technical capacity) was transmitted east to Zealand (DK1→DK2) and 0.6 TWh (12d % of the technical capacity) was transmitted west to Jutland (DK2→DK1).

Annual maintenance for Storebaelt lasted 4 days. There were two minor planned maintenance outages and two minor disturbance outages.

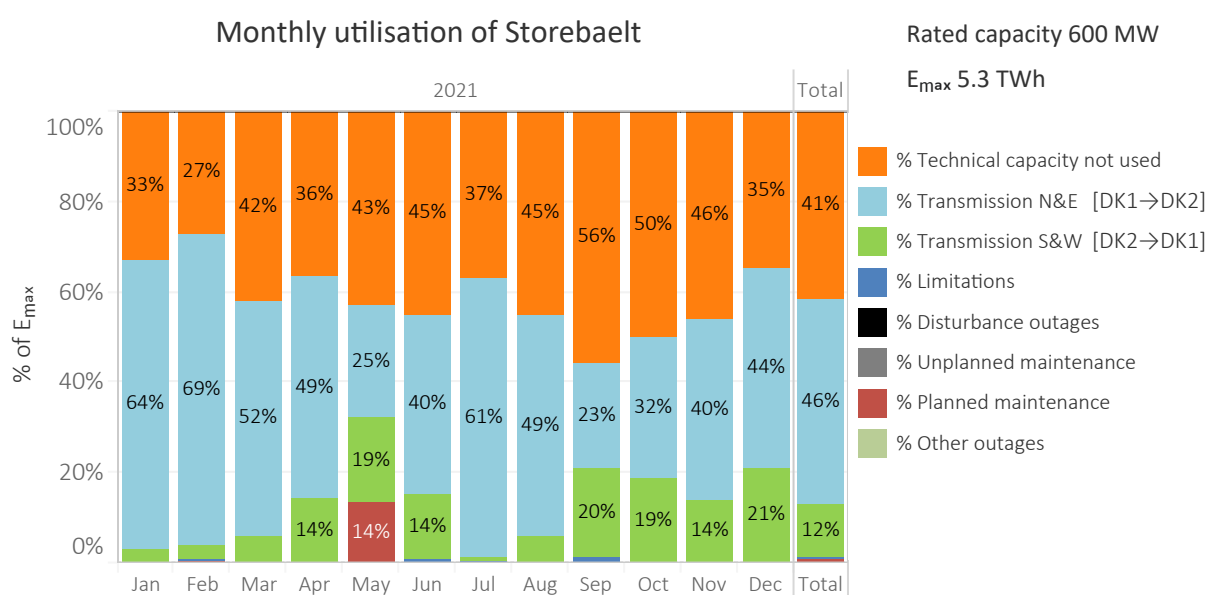

Figure 5.77: Monthly percentage allocation of utilisation by category for Storebaelt in 2021. The availability and utilisation categories are defined in detail in Chapter 3.

Table 5.22: Monthly allocation of technical capacity ( $E_{max}$ ) for Storebaelt in 2021. Note that losses are not included in the technical capacity ( $E_{max}$ ), as is shown in Figure 3.1.

	Jan	Feb	Mar	Apr	May	Jun	Jul	Aug	Sep	Oct	Nov	Dec	Total	% total
Technical capacity not used, GWh	148.2	109.7	187.6	157.3	191.2	194.1	165.4	200.7	241.2	222.2	198.4	156.2	2172.1	41.3%
Transmission N&E, GWh	283.7	277.3	231.9	212.3	110.8	172.2	274.3	219.2	100.7	141.1	173.3	196.5	2393.4	45.5%
Transmission S&W, GWh	14.1	13.5	26.9	62.4	83.8	61.4	4.4	26.5	85.3	83.1	60.3	93.7	615.2	11.7%
Limitations, GWh	0.4	0.4	-	-	-	3.6	2.3	-	4.9	-	-	-	11.5	0.2%
Disturbance outages, GWh	-	-	-	-	-	0.1	-	-	-	-	0.1	-	0.2	0.0%
Unplanned maintenance, GWh	-	-	-	-	-	-	-	-	-	-	-	-	-	-
Planned maintenance, GWh	-	2.3	-	-	60.6	0.6	-	-	-	-	-	-	63.6	1.2%
Other outages, GWh	-	-	-	-	-	-	-	-	-	-	-	-	-	-
Total, GWh	446.4	403.2	446.4	432.0	446.4	432.0	446.4	446.4	432.0	446.4	432.0	446.4	5256.0	100.0%
Losses SW, GWh	0.3	0.2	0.4	0.9	1.3	1.0	0.1	0.4	1.3	1.3	1.0	1.5	9.7	0.2%
Losses NE, GWh	4.9	4.8	3.9	3.6	1.8	2.8	4.6	3.7	1.7	2.4	2.9	3.4	40.4	0.8%

Figure 5.78 presents the annual utilisation of Storebaelt per utilisation and unavailability category for the years 2012–2021.

Figure 5.79 presents the percentage of hours of a year Storebaelt has been affected by either a limitation, a dis-

turbance outage, an unplanned or planned maintenance outage or other outage annually during the years 2012–2021. Figure 5.80 presents the annual number of disturbance outages, unplanned and planned maintenances and other outages during the years 2012–2021.

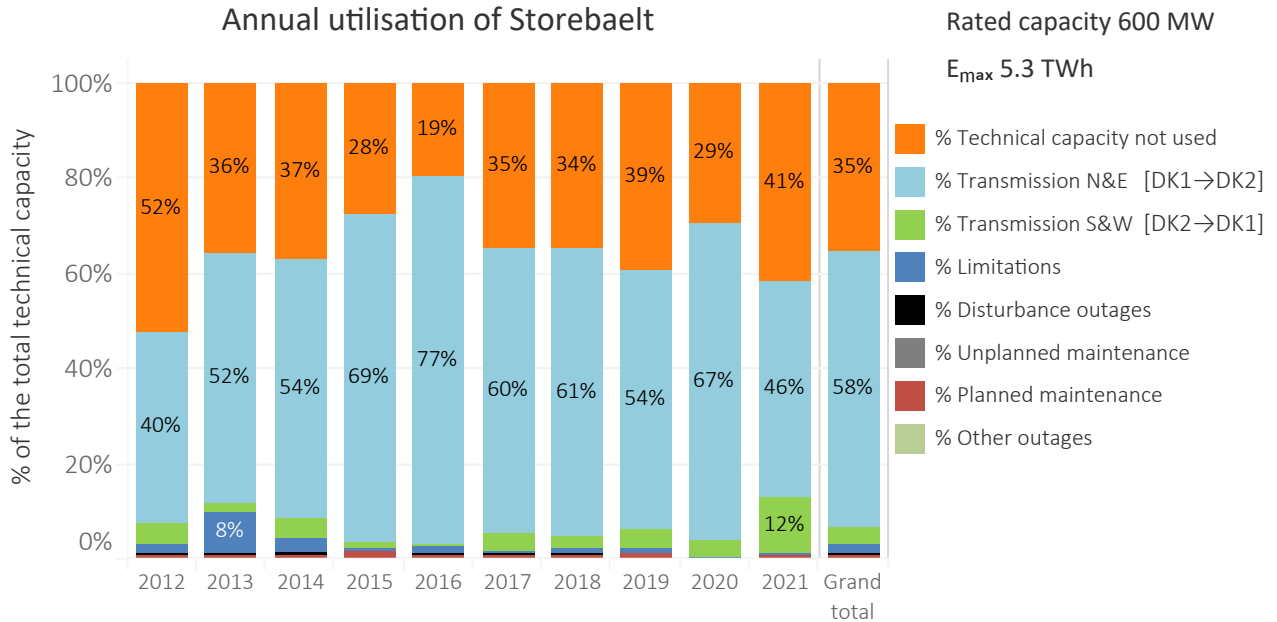

Figure 5.78: Annual utilisation of Storebaelt per the utilisation and unavailability categories for the years 2012–2021. The utilisation and unavailability categories are described in more detail in Chapter 3.

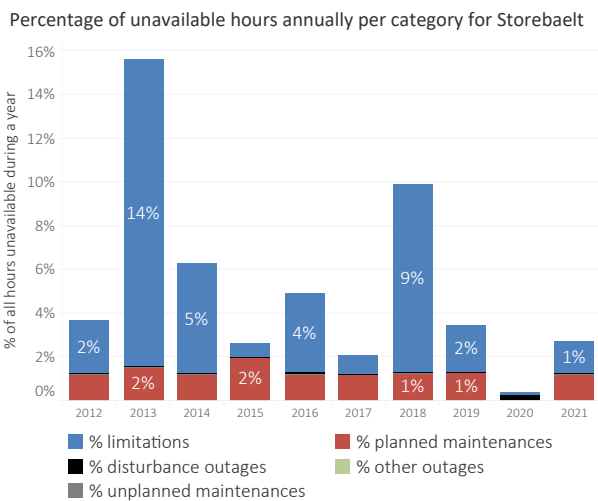

Figure 5.79: Percentage of hours Storebaelt has been affected by either a limitation or an outage annually since 2012. The percentage is calculated by counting the number of hours with a limitation or outage and dividing it by the total number of hours in a year. It should be noted that any single hour can be affected by both an outage and a limitation.

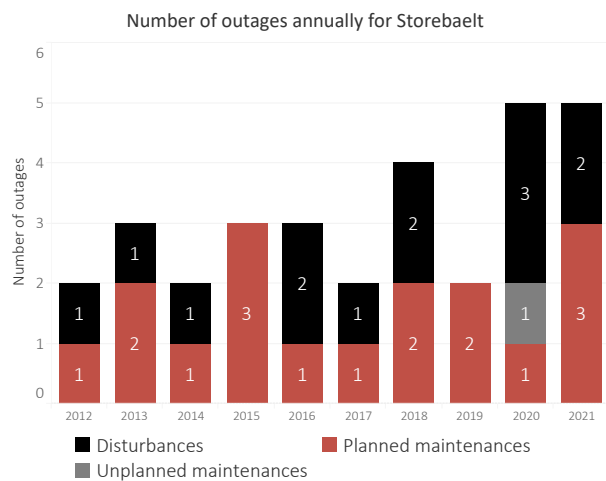

Figure 5.80: The annual number of disturbances, unplanned and planned maintenance outages and other outages for Storebaelt for the years 2012–2021. Storebaelt had no other outages during the years 2012–2021.

### 5.3.20 SwePol

Figure 5.81 presents the availability and utilisation of SwePol for 2021 and Table 5.23 presents the numerical values behind it. SwePol Link has been in operation since 2000 and it connects the Swedish and Polish transmission grids. In south-eastern Sweden (bidding zone SE4) it is connected to Stårnö and in Poland (bidding zone PL) to Slupsk. The transmission capacity is 600 MW.

In 2020, SwePol had an available technical capacity of 91 %. The technical capacity not used was 22 %. Totally, 3.4 TWh

(65 % of the technical capacity) was transmitted south (SE4→PL) and 0.2 TWh (4 % of the technical capacity) was transmitted north (PL→SE4).

The annual maintenance of SwePol lasted 6 days in September. Additionally, SwePol had 10 other planned maintenance outages during 2021. There were 5 minor disturbance outages, of which one lasted more than 8 hours. SwePol was offline due to disturbance outages for 49 hours in total in 2021.

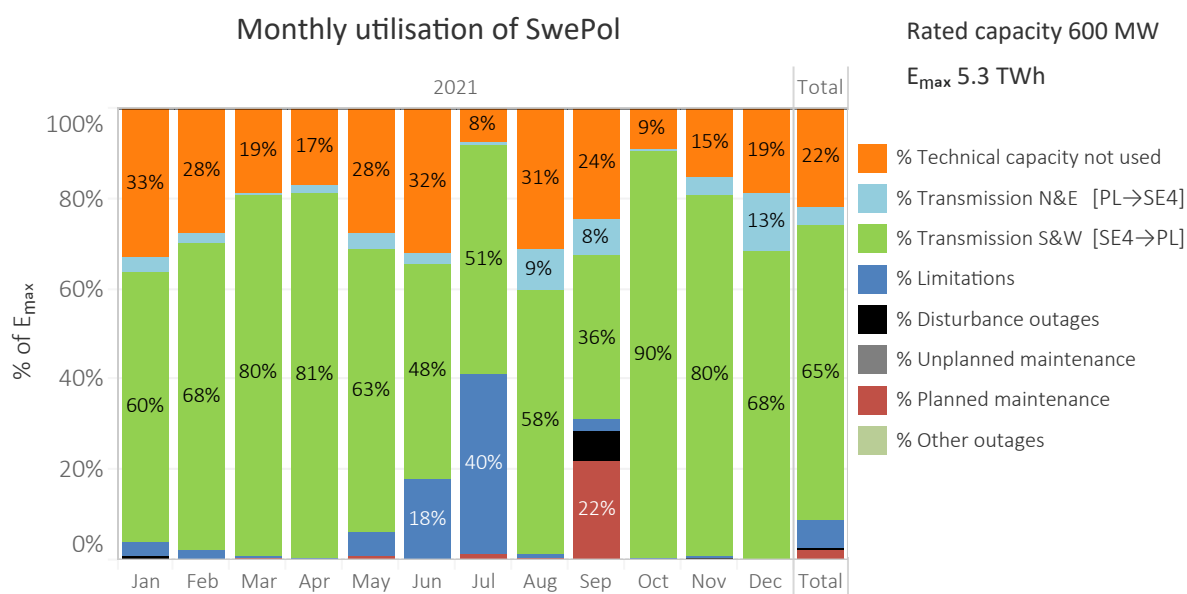

Figure 5.81: Monthly percentage allocation of utilisation by category for SwePol in 2021. The availability and utilisation categories are defined in detail in Chapter 3.

Table 5.23: Monthly allocation of technical capacity (E<sub>max</sub>) for SwePol in 2021. Note that losses are not included in the technical capacity (E<sub>max</sub>), as is shown in Figure 3.1.

Monthly utilisation of SwePol (South & West direction SE4→PL)														Total	% total
	Jan	Feb	Mar	Apr	May	Jun	Jul	Aug	Sep	Oct	Nov	Dec			
Technical capacity not used, GWh	147.7	112.0	82.9	72.4	123.3	139.1	34.5	138.6	105.7	40.3	64.7	84.4	1145.7	21.8%	
Transmission N&E, GWh	13.9	9.0	1.1	7.8	16.1	9.4	0.9	41.5	34.8	1.3	18.2	56.2	210.2	4.0%	
Transmission S&W, GWh	266.6	273.2	357.5	349.9	279.3	207.1	227.8	259.3	157.5	403.3	345.7	305.1	3432.4	65.3%	
Limitations, GWh	14.3	8.4	1.3	1.9	24.1	76.4	177.3	4.3	9.7	1.4	1.2	0.7	321.0	6.1%	
Disturbance outages, GWh	3.9	0.6	-	-	-	-	-	-	30.2	-	1.1	-	35.7	0.7%	
Unplanned maintenance., GWh	-	-	-	-	-	-	-	-	-	-	-	-	-	-	
Planned maintenance, GWh	-	-	3.6	-	3.5	-	5.8	2.6	94.2	0.1	1.2	-	110.9	2.1%	
Other outages, GWh	-	-	-	-	-	-	-	-	-	-	-	-	-	-	
Total, GWh	446.4	403.2	446.4	432.0	446.4	432.0	446.4	446.4	432.0	446.4	432.0	446.4	5256.0	100.0%	
Losses SW, GWh	7.3	7.8	10.3	9.9	7.6	5.1	4.9	7.1	4.3	11.9	10.1	8.8	95.1	1.8%	
Losses NE, GWh	0.3	0.2	-	0.2	0.4	0.2	-	1.1	0.9	-	0.5	1.6	5.5	0.1%	

Figure 5.82 presents the annual utilisation of SwePol per utilisation and unavailability category for the years 2012–2021.

Figure 5.83 presents the percentage of hours of a year SwePol has been affected by either a limitation, a distur-

bance outage, an unplanned or planned maintenance outage or other outage annually during the years 2012–2021. Figure 5.84 presents the annual number of disturbance outages, unplanned and planned maintenances and other outages during the years 2012–2021.

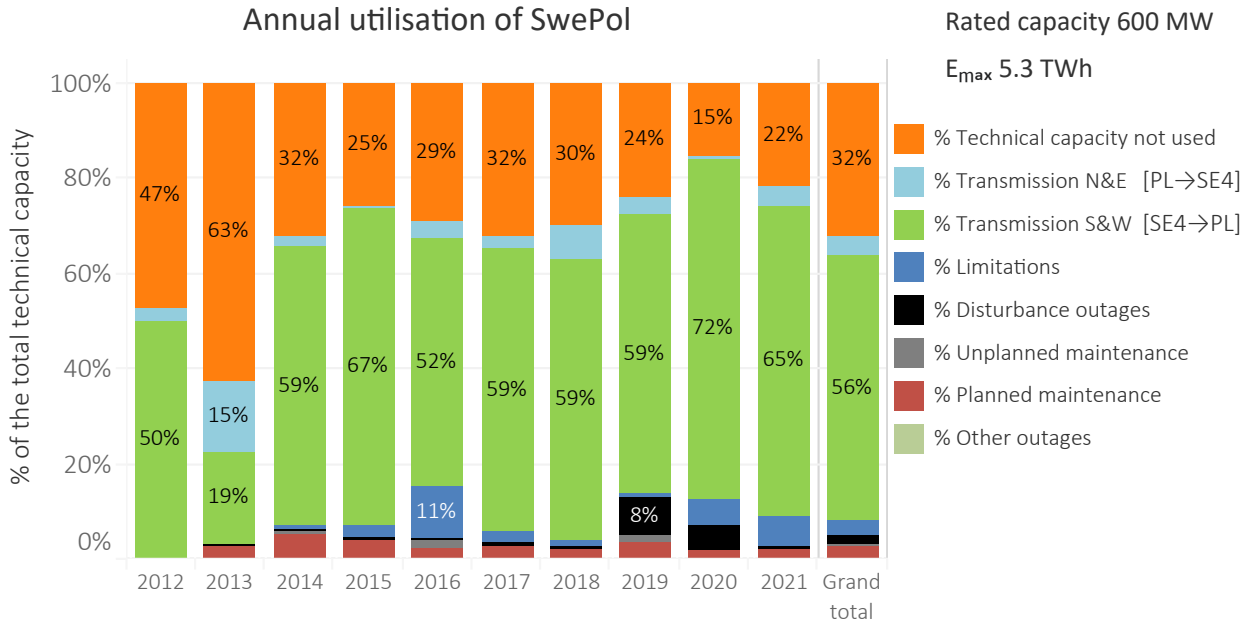

Figure 5.82: Annual utilisation of SwePol per the utilisation and unavailability categories for the years 2012–2021. The utilisation and unavailability categories are described in more detail in Chapter 3.

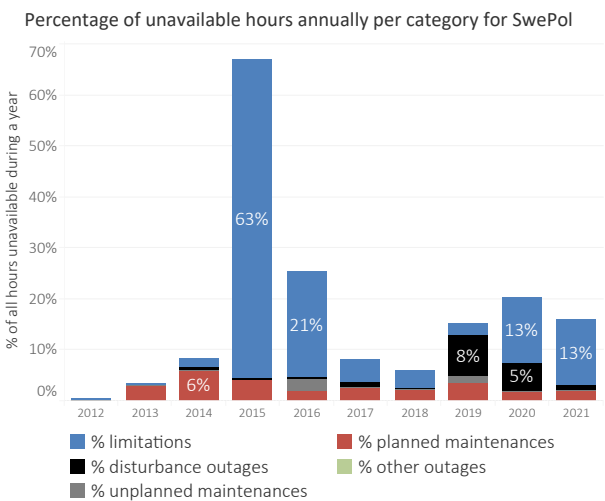

Figure 5.83: Percentage of hours SwePol has been affected by either a limitation or an outage annually since 2012. The percentage is calculated by counting the number of hours with a limitation or outage and dividing it by the total number of hours in a year. It should be noted that any single hour can be affected by both an outage and a limitation.

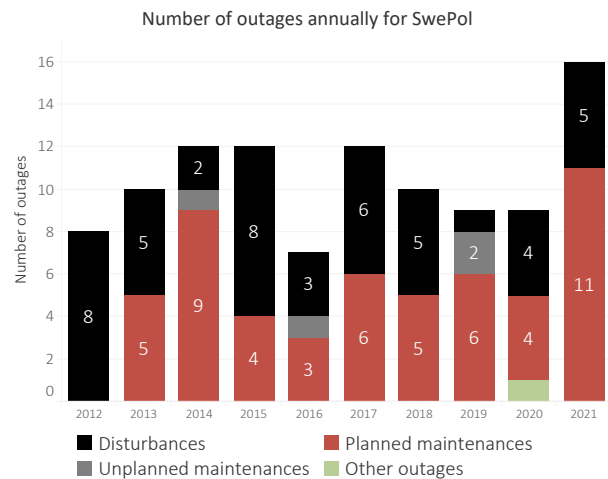

Figure 5.84: The annual number of disturbances, unplanned and planned maintenance outages and other outages for SwePol for the years 2012–2021. SwePol had no other outages during the years 2012–2021.

### 5.3.21 Vyborg Link

Figure 5.85 and Figure 5.86 present the monthly availability and utilisation of the Vyborg Link separately for each direction for 2021. Table 5.24 and Table 5.25 present the numerical values behind the monthly figures. Vyborg Link is a back-to-back HVDC connection between Russia and Finland. The HVDC substation is located in Vyborg, Russia, and the 400 kV lines from Vyborg are connected to substations Ylikkälä and Kymi in southern Finland.

Vyborg link was first commissioned in 1981 with a rated capacity of 350 MW. Additional 350 MW converter blocks were installed in 1982, 1984, and 2000. The total technical capacity is 4x350 MW and the commercial transmission capacity is 1.3 GW (with 100 MW allocated for reserves).

The transmission direction before 2014 was only to Finland. In September 2014, one 350 MW unit was tested to also transmit in the other direction. As a result, the trade to Russia was possible with 320 MW (with 30 MW allocated for reserves) in December 2014.

The trade between Russia and Finland ended on 14 May

2022 as a result of the war started by Russia against Ukraine on 24 February 2022.

In 2021, the Vyborg Link had an available technical capacity of 94 % in the direction RU→FI. The technical capacity not used was 23 %. Totally, 8.2 TWh (72 % of the technical capacity) was transmitted west to Finland (RU→FI).

The available technical capacity was 78 % in the direction FI→RU. The technical capacity not used was 78 %. No energy was transmitted east to Russia (FI→RU).

In 2021, there were two annual maintenances of Vyborg Link, lasting 31 days in July and 28 days in May. Additionally, there were two other planned maintenance outages in October. Maintenance work on Vyborg Link causes normally only limitations because the 350 MW units are not worked on simultaneously. Vyborg Link had seven disturbance outages during 2021, of which two lasted longer than 24 hours. Furthermore, there were five planned and 13 unplanned limitations.

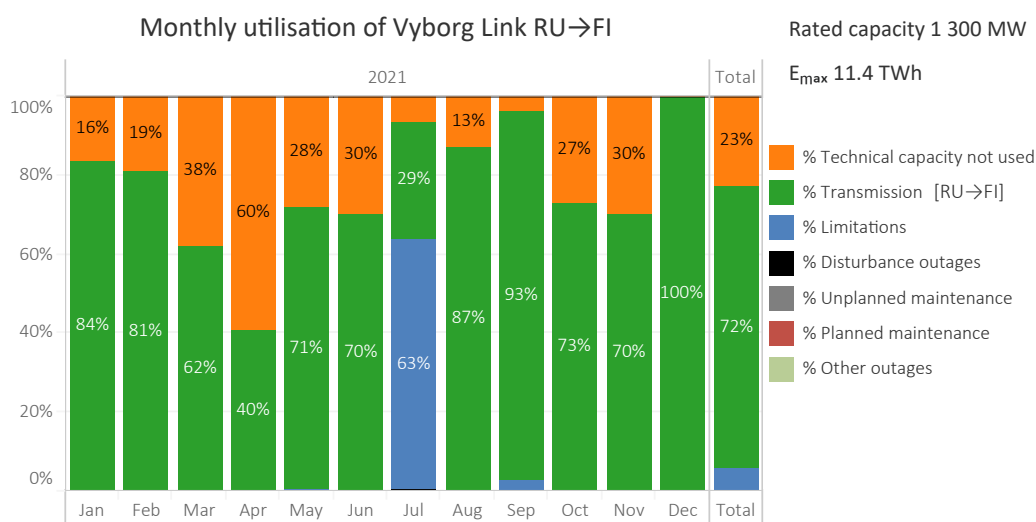

Figure 5.85: Monthly percentage allocation of utilisation by category for Vyborg Link in direction RU→FI in 2021. The availability and utilisation categories are defined in detail in Chapter 3.

Table 5.24: Monthly allocation of technical capacity (E<sub>max</sub>) in direction RU→FI for Vyborg Link in 2021.

Monthly utilisation of Vyborg Link RU→FI	Jan	Feb	Mar	Apr	May	Jun	Jul	Aug	Sep	Oct	Nov	Dec	Total	% total
Technical capacity not used, GWh	159.4	166.6	365.2	557.6	272.6	281.2	66.6	126.5	38.6	261.4	278.2	4.0	2578.0	22.6%
Transmission, GWh	807.8	707.0	602.0	378.4	690.5	654.8	281.7	840.0	872.1	705.8	656.5	963.2	8159.8	71.7%
Limitations, GWh	-	-	-	-	4.1	-	613.9	0.7	25.3	-	1.3	-	645.3	5.7%
Disturbance outages, GWh	-	-	-	-	-	-	5.0	-	-	-	-	-	5.0	0.0%
Unplanned maintenance, GWh	-	-	-	-	-	-	-	-	-	-	-	-	-	-
Planned maintenance, GWh	-	-	-	-	-	-	-	-	-	-	-	-	-	-
Other outages, GWh	-	-	-	-	-	-	-	-	-	-	-	-	-	-
Total, GWh	967.2	873.6	967.2	936.0	967.2	936.0	967.2	967.2	936.0	967.2	936.0	967.2	11388.0	100.0%

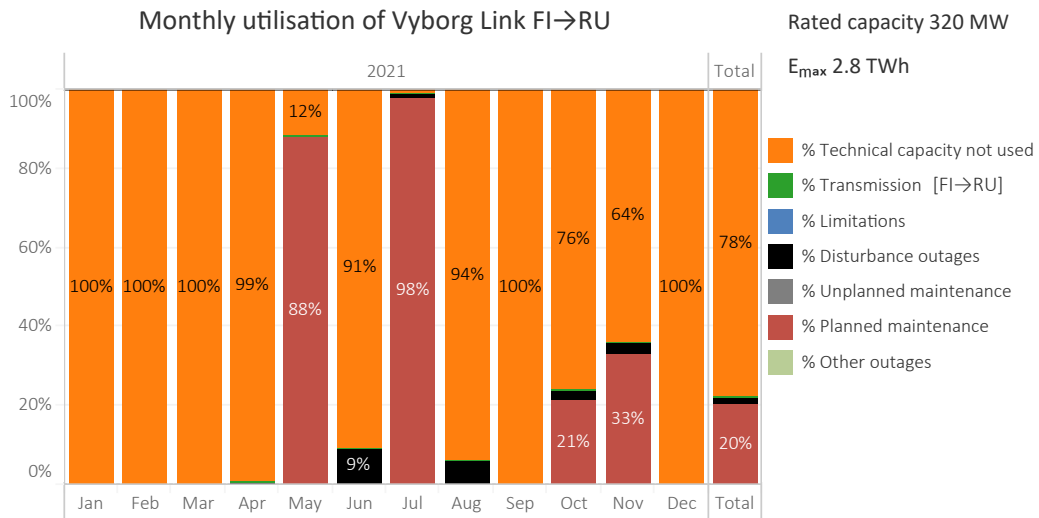

Figure 5.86: Monthly percentage allocation of utilisation by category for Vyborg Link in direction FI→RU in 2021. The availability and utilisation categories are defined in detail in Chapter 3.

Table 5.25: Monthly allocation of technical capacity (E<sub>max</sub>) in direction FI→RU for Vyborg Link in 2021.

Monthly utilisation of Vyborg Link FI→RU													Total	% total
	Jan	Feb	Mar	Apr	May	Jun	Jul	Aug	Sep	Oct	Nov	Dec		
Technical capacity not used, GWh	238.1	215.0	238.1	228.1	27.8	208.9	2.4	223.0	230.4	180.5	147.5	238.1	2178.0	77.7%
Transmission, GWh	-	-	-	-	-	-	-	-	-	-	-	-	-	0.0%
Limitations, GWh	-	-	-	-	-	-	-	-	-	-	-	-	-	-
Disturbance outages, GWh	-	-	-	2.3	-	21.5	2.4	15.0	-	6.9	6.8	-	54.8	2.0%
Unplanned maintenance, GWh	-	-	-	-	-	-	-	-	-	-	-	-	-	-
Planned maintenance, GWh	-	-	-	-	210.2	-	233.3	-	-	50.7	76.2	-	570.4	20.3%
Other outages, GWh	-	-	-	-	-	-	-	-	-	-	-	-	-	-
Total, GWh	238.1	215.0	238.1	230.4	238.1	230.4	238.1	238.1	230.4	238.1	230.4	238.1	2803.2	100.0%

Figure 5.87 presents the annual utilisation of Vyborg Link per utilisation and unavailability category for the years 2012–2021.

Figure 5.88 presents the percentage of hours of a year Vyborg Link has been affected by either a limitation, a dis-

turbance outage, an unplanned or planned maintenance outage or other outage annually during the years 2012–2021. Figure 5.89 presents the annual number of disturbance outages, unplanned and planned maintenances and other outages during the years 2012–2021.

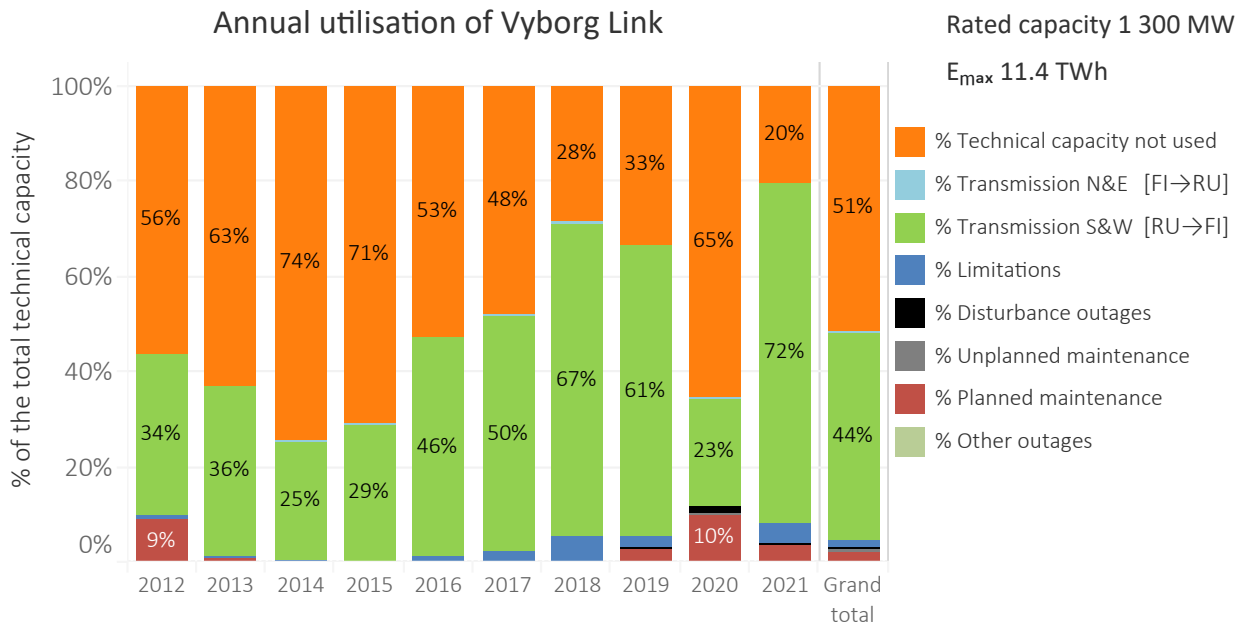

Figure 5.87: Annual utilisation of Vyborg Link per the utilisation and unavailability categories for the years 2012–2021. The utilisation and unavailability categories are described in more detail in Chapter 3.

Percentage of unavailable hours annually per category for Vyborg Link

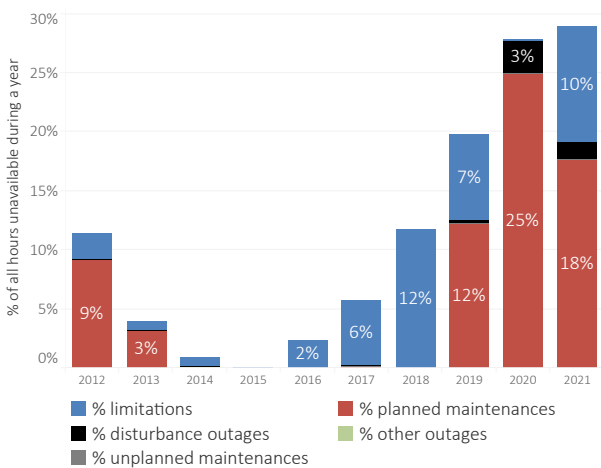

Figure 5.88: Percentage of hours Vyborg Link has been affected by either a limitation or an outage annually since 2012. The percentage is calculated by counting the number of hours with a limitation or outage and dividing it by the total number of hours in a year. It should be noted that any single hour can be affected by both an outage and a limitation.

Number of outages annually for Vyborg Link

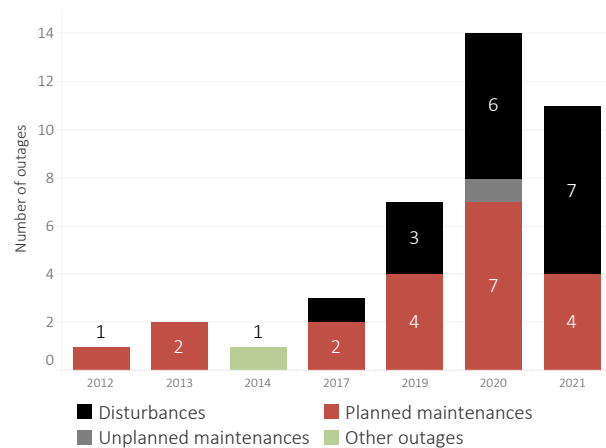

Figure 5.89: The annual number of disturbances, unplanned and planned maintenance outages and other outages for Vyborg Link for the years 2012–2021.



## References

- [1] DISTAC, "Nordic Grid Disturbance Statistics 2010." [https://eepublicdownloads.entsoe.eu/clean-documents/pre2015/publications/entsoe/RG\\_SOC\\_Nordic/110831\\_NORDIC\\_GRID\\_DISTURBANCE\\_AND\\_FAULT\\_STATISTICS\\_2010.pdf](https://eepublicdownloads.entsoe.eu/clean-documents/pre2015/publications/entsoe/RG_SOC_Nordic/110831_NORDIC_GRID_DISTURBANCE_AND_FAULT_STATISTICS_2010.pdf), August 2010.
- [2] CIGRE Technical Brochure, "Protocol for reporting the operational performance of HVDC Transmission Systems," technical brochure, CIGRE, 2014.

## Glossary

**DISTAC** Disturbance Statistics Group. Reports to Regional Group Nordic (RGN) in ENTSO-E.

**ENTSO-E** European Network of Transmission System Operators for Electricity.

**HVAC** High-voltage alternating current.

**HVDC** High-voltage direct current.

**LCC** Line-commutated converters.

**NordAM** Nordic Asset Management Forum.

**PEX** Cross-linked polyethylene.

**RGN** Regional Group Nordic.

**TSO** Transmission System Operator.

**VSC** Voltage-source converters.

# Appendices

# A Schematic presentation of HVDC links

Figure A.1 and Figure A.2 show the schematic presentations of a HVDC converter station having line-commutated converters (LCC) and voltage-source converters (VSC), respectively. All the figures also show definitions for the origin of an event. The origin of each event is used for categorizing a disturbance or a limitation for statistical purposes.

The figures also show the locations of the circuit breakers and measurement points for transferred energy on a link.

It should be noted that these figures are only show an example of a possible LCC or VSC converter station as there are multiple different ways to construct one.

## Schematic of a line-commutated converter HVDC station

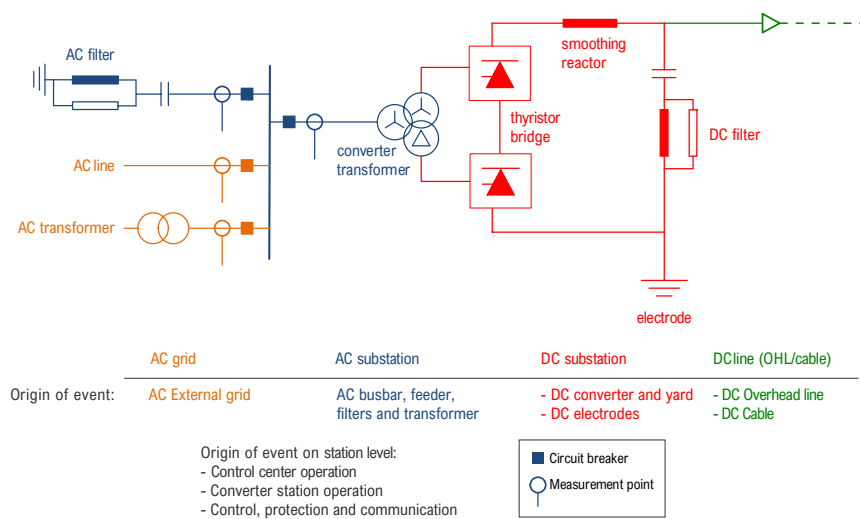

Figure A.1: An example of a line-commutated converter (LCC) station schematic with the connection to the AC grid. The other remote side of the HVDC link has a similar albeit mirrored version of the converter station.

## Schematic of a voltage-source converter HVDC station

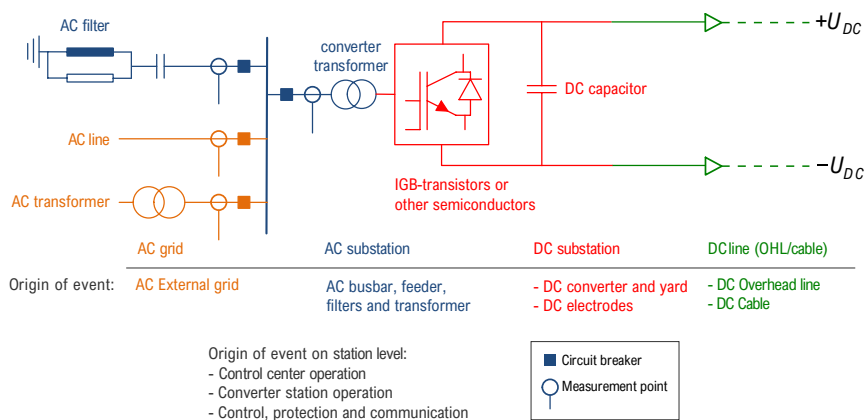

Figure A.2: An example of a voltage-source converter (VSC) station schematic with the connection to the AC grid. The other remote side of the HVDC link has a similar albeit mirrored version of the converter station.

## B DISTAC/CIGRE origin of event classification

Table B.1 show the DISTAC origins and their subcategories and the corresponding CIGRE outage codes [2]. It should be noted that full compatibility is not achieved in control and protection areas. The schematics in Appendix A can be helpful in visualizing the different categories.

Table B.1: The DISTAC origin of event categories and subcategories and the corresponding CIGRE outage codes.

DISTAC Origin of event	DISTAC / CIGRE Subcategory / Outage Code	Comment
Multiple places	-	Used primarily for annual maintenance in DISTAC.
Control centre operation <sup>1</sup>	C-P.L – Local HVDC Control & Protection <sup>1</sup>	Control, protection or monitoring equipment of the local HVDC station, for example, converter firing control, current and voltage regulators, converter and dc yard protections, valve control and protection, and local control sequences.
	C-P.M – Master HVDC Control & Protection <sup>1</sup>	Equipment used for inter-station coordination of current and voltage orders, inter-station sequences, auxiliary controls such as damping controls or higher level controls such as run-back/run-up power control or frequency control.
	C-P.T – Control & Protection and Telecommunication <sup>1</sup>	Equipment for coding of control and indication information to be sent over a telecommunication circuit including the telecommunication circuit itself (microwave, PLC or optical).
Converter station operation <sup>1</sup>	Same as for “Control centre operation” above	
Control, protection and communication <sup>1</sup>	Same as for “Control centre operation” above	
AC External grid AC and auxiliary equipment	EXT – External AC System	
	AC-E.F – AC Filter and Shunt Bank	Including AC filter CTs, arresters as well as PLC/RI, SVC, STAT-COM, series capacitor at HVDC station.
	AC-E.SW – Other AC Switchyard Equipment	For example, switches, surge arresters, busbars, insulators.
	AC-E.CP – AC Control and Protection	AC C&P including CTs, VTs, also for auxiliary power and valve cooling.
	AC-E.TX – Converter Transformer	Including interface transformers.
DC converter and yard	AC-E.SC – Synchronous Compensator	Including SC cooling system and exciter.
	AC-E.AX – Auxiliary Equipment and Auxiliary Power	For example, auxiliary transformers, pumps, battery chargers, heat exchangers, cooling system instrumentation, LV switchgear, motor control centres, fire protection, civil works.
	V.E – Valve Electrical	
	V.VC – Valve Cooling	Valve Cooling pipes and parts in valve hall.
	V.C – Valve Capacitor	
	DC-E.F – DC Filters	
	DC-E.SR – DC Smoothing Reactor	
DC-E.SW – DC Switching Equipment		
DC Electrodes	DC-E.ME – DC Measuring Equipment	
	DC-E.O – Other DC Yard and Valve Hall Equipment	
	DC-E.GE – DC Ground Electrode	
DC Overhead line	DC-E.EL – DC Ground Electrode Line	
DC Cable	TL-OH – DC Overhead Transmission Line	
Other or unknown	TL-C – DC Underground / submarine Cable	
	O – Other	

<sup>1</sup> There is no direct one-to-one compatibility between DISTAC and CIGRE for these definitions.

## C Contact persons

Denmark	<p>Energinet Tonne Kjærsvvej 65 DK-7000 Fredericia, Denmark</p> <p>Anders Bratløv Tel. +45 51 38 01 31 E-mail: anv@energinet.dk</p> <p>Morten Vadstrup Tel. +45 31 58 17 43 E-mail: mvd@energinet.dk</p>	Norway	<p>Statnett SF Nydalen allé 33, PB 4904 Nydalen NO-0423 Oslo</p> <p>Jørn Schaug-Pettersen Tel. +47 23 90 35 55 E-mail: jsp@statnett.no</p>
Estonia	<p>Elering AS Kadaka tee 42 Tallinn, Estonia</p> <p>Irene Puusaar Tel. +372 508 4372 E-mail: irene.puusaar@elering.ee</p> <p>Kaur Krusell Tel. +372 564 86011 E-mail: kaur.krusell@elering.ee</p>	Sweden	<p>Svenska kraftnät Sturegatan 1, P.O. Box 1200 SE-172 24 Sundbyberg</p> <p>Jeremy lehl Tel: +46 10 475 87 78 Mobile: +46 70 512 28 18 E-mail: Jeremy.lehl@svk.se</p>
Finland	<p>Fingrid Oyj Läkkisepäntie 21, P.O. Box 530 FI-00101 Helsinki, Finland</p> <p>Markku Piironen Tel. +358 30 395 4172 Mobile +358 40 351 1718 E-mail: markku.piironen@fingrid.fi</p>	Publisher	<p>ENTSO-E AISBL Rue de Spa 8 1000 Brussels, Belgium Tel. +32 2 741 09 50 info@entsoe.eu www.entsoe.eu</p>
Lithuania	<p>Litgrid AB Karlo Gustavo Emilio Manerheimo st. 8 LT-05131, Vilnius</p> <p>Valdas Tarvydas Tel. +370 7070 2207 E-mail: valdas.tarvydas@litgrid.eu</p>		

## D Sorted overview of utilisation and unavailability for all HVDC links

This chapter presents sorted versions of Figure 5.1 Utilisation (%) by category for each HVDC link in 2021.

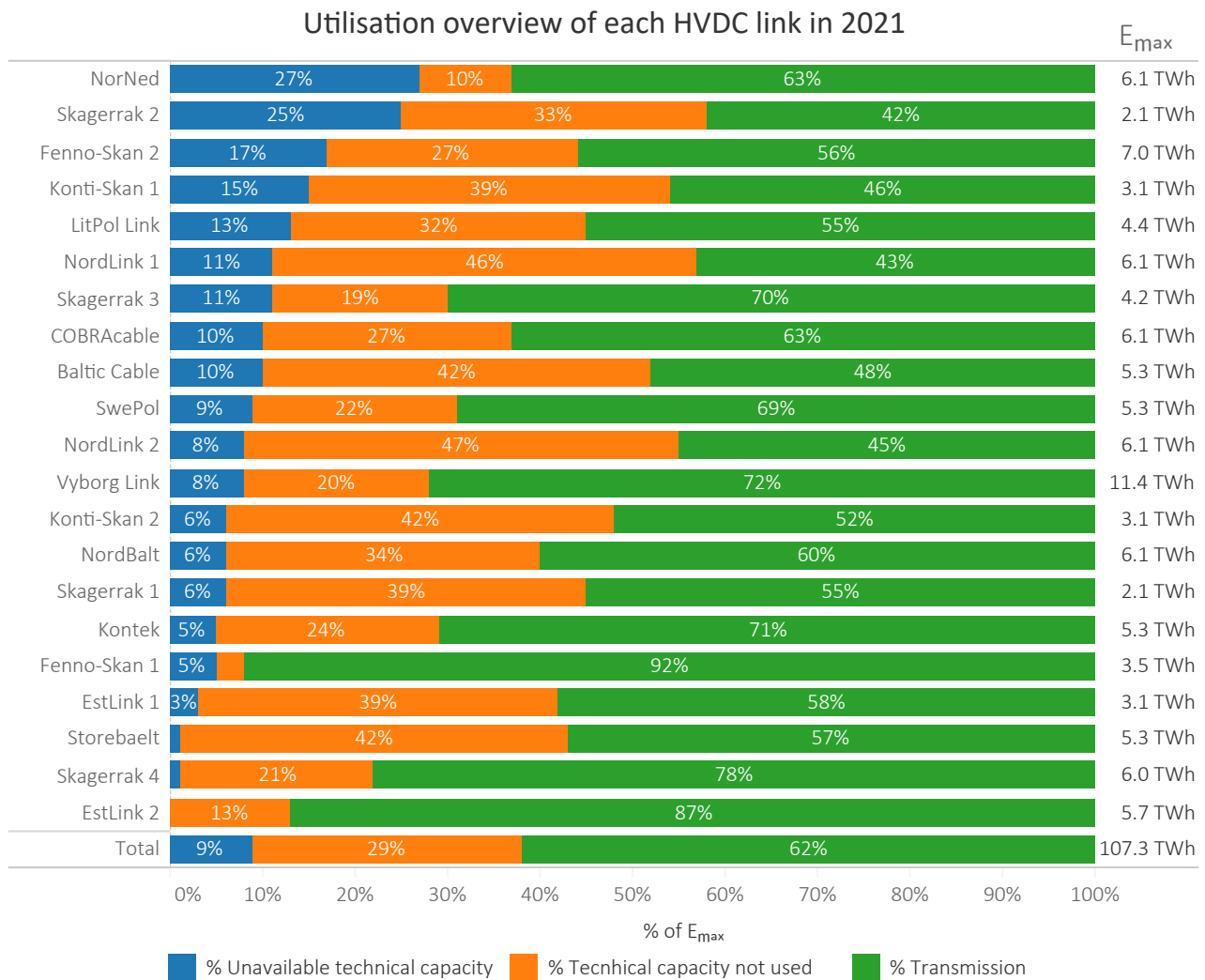

Figure D.1: Overview of each HVDC link sorted by descending unavailable technical capacity ( $E_U$ ) in 2021.

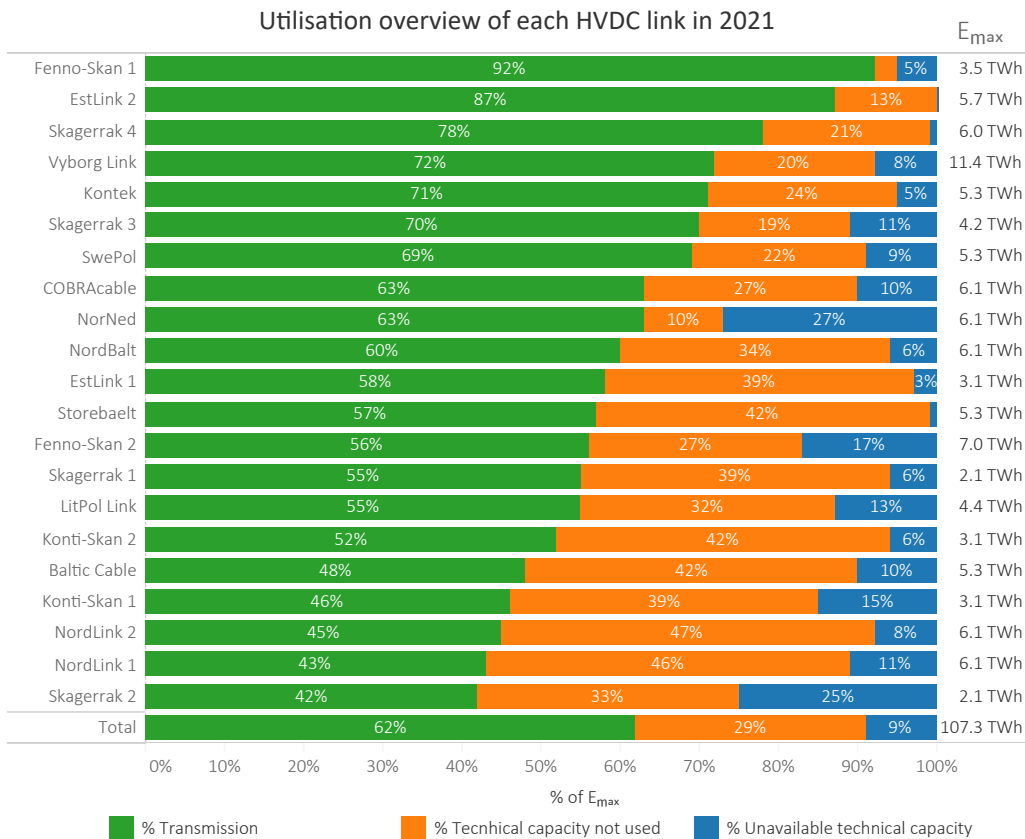

Figure D.2: Overview of each HVDC link sorted by descending transmission ( $E_T$ ) in 2021.

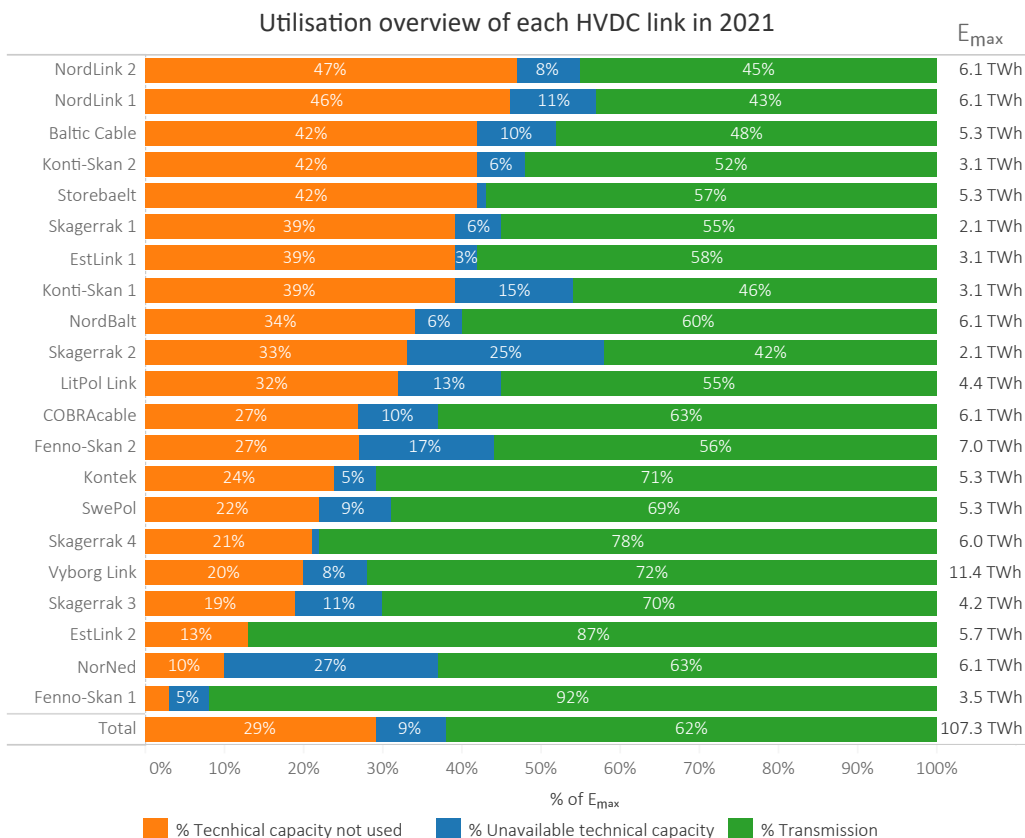

Figure D.3: Overview of each HVDC link sorted by descending technical capacity not used ( $E_{TCNU}$ ) in 2021.



## E Additional figures

This appendix was introduced to allow experimenting with new kinds of figures without affecting the rest of the report. Furthermore, it shows what kind of statistical data can be derived from the data collected by the DISTAC group.

### E.1 Annual utilisation per type of HVDC converter

Figure E.1 presents the annual utilisation of all HVDC links using line-commutated converters (LCC) and Figure E.2 all HVDC links using voltage-source converters (VSC).

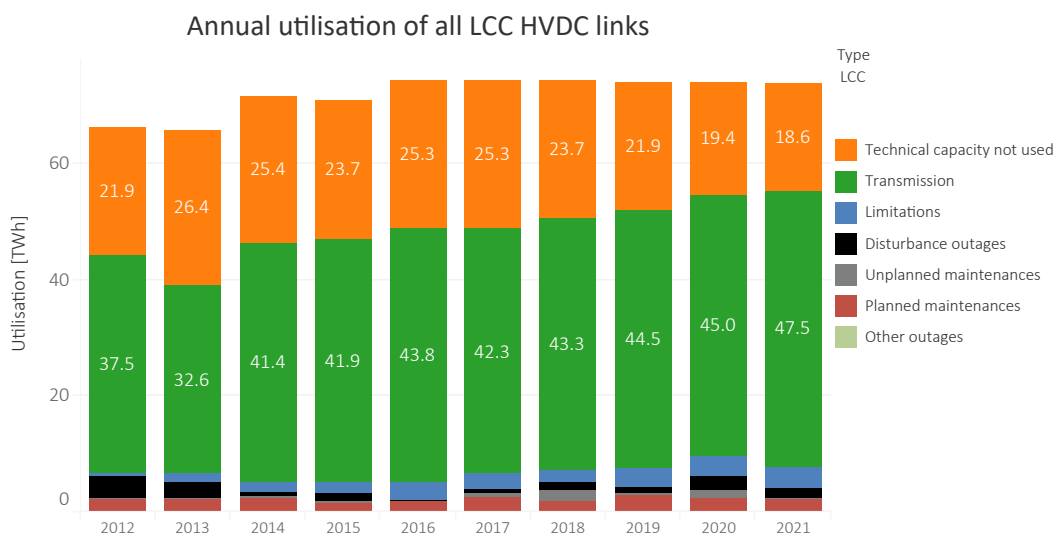

Figure E.1: Annual utilisation of all HVDC links using line-commutated converters (LCC) together presented in megawatt hours (MWh).

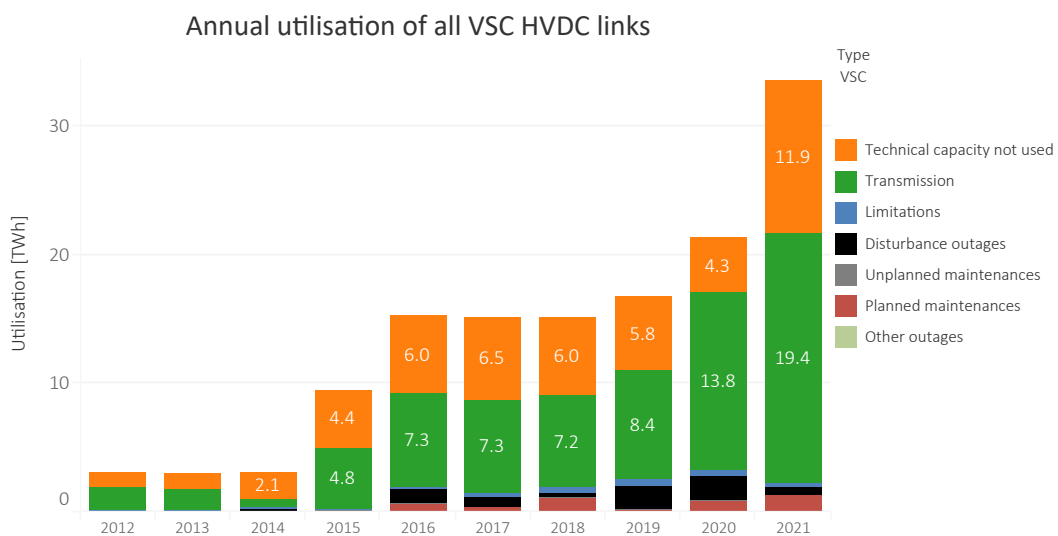

Figure E.2: Annual utilisation of all HVDC links using voltage-source converters (VSC) together presented in megawatt hours (MWh).

## E.2 Additional figures with percentages of hours unavailable

This section presents additional figures with a more detailed categorisation of unavailability. Figure E.3 presents the hours (%) limited due to seasonal causes annually for all HVDC links. Figure E.4 presents the hours (%) limited by limitation origin and type annually for all HVDC links. The limitation origins are AC and DC limiting conditions, and the types are planned or unplanned.

Figure E.5 presents the hours (%) limited by limitation origin and type in 2021 for each HVDC link. Figure E.6 presents the same but for each market connection.

Figure E.7 presents hours (%) unavailable due to planned maintenance by primary cause in 2021 for each HVDC link and the corresponding annual values for all HVDC links combined.

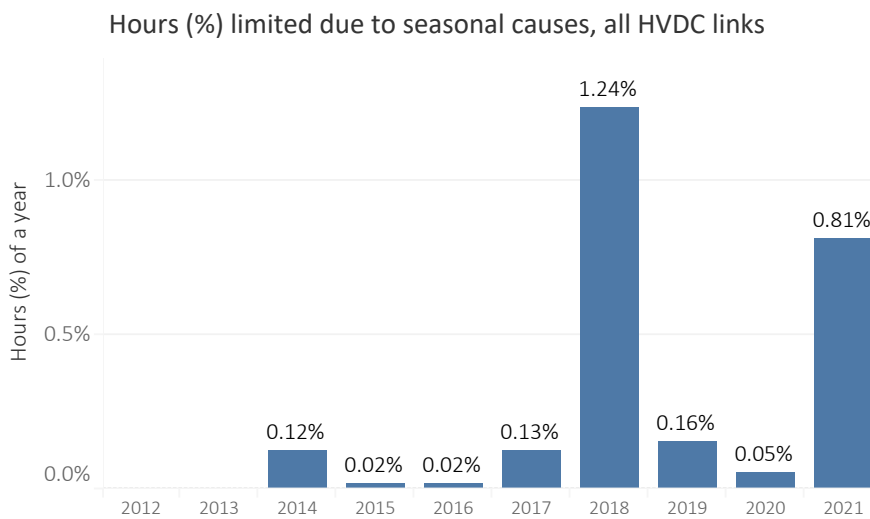

Figure E.3: Hours (%) limited due seasonal causes for all HVDC links. The percentage is calculated by counting the number of hours with a limitation due to seasonal causes and dividing it by the total number of hours in a year.

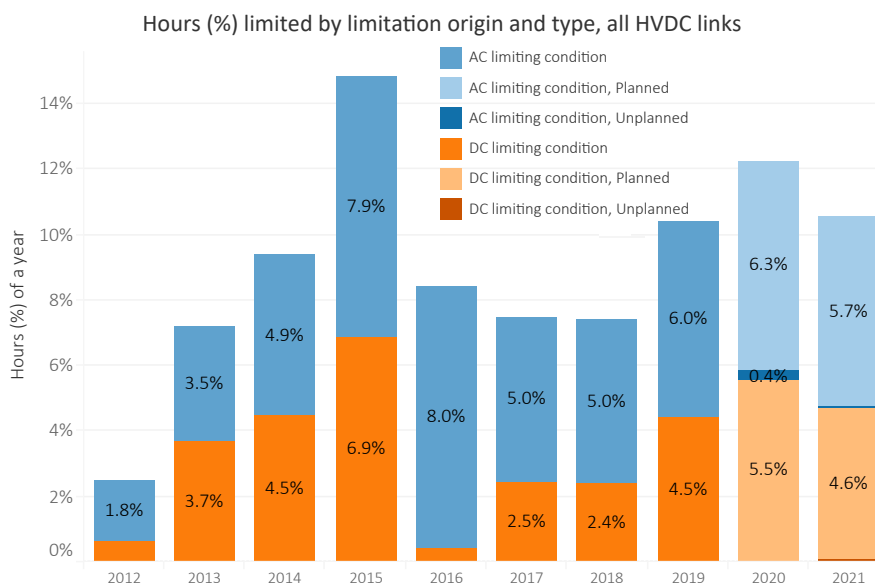

Figure E.4: Hours (%) by limitation origin and type annually for all HVDC links. The limitation origins are AC limiting and DC limiting and the types are planned and unplanned. The percentage is calculated by counting the number of hours with the specific limitation origin and type and dividing it by the total number of hours in a year. Limitation type was not recorded prior to 2020.

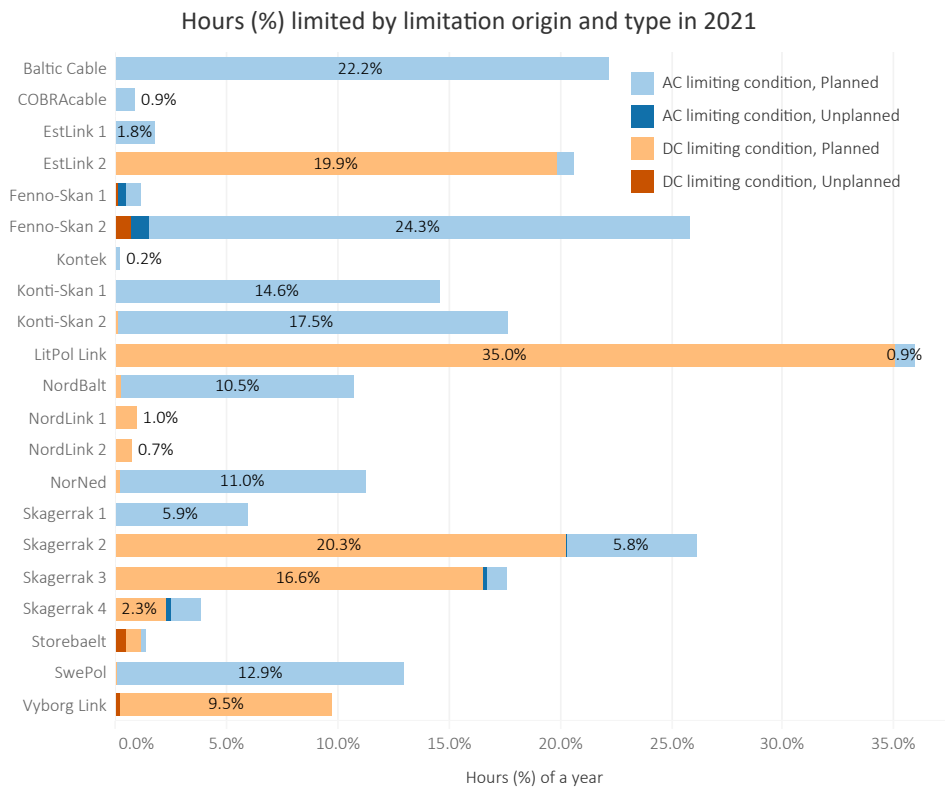

Figure E.5: Hours (%) limited by limitation origin and type in 2021 for each HVDC link. The percentage is calculated by counting the number of hours with the specific limitation origin and type and dividing it by the total number of hours in a year.

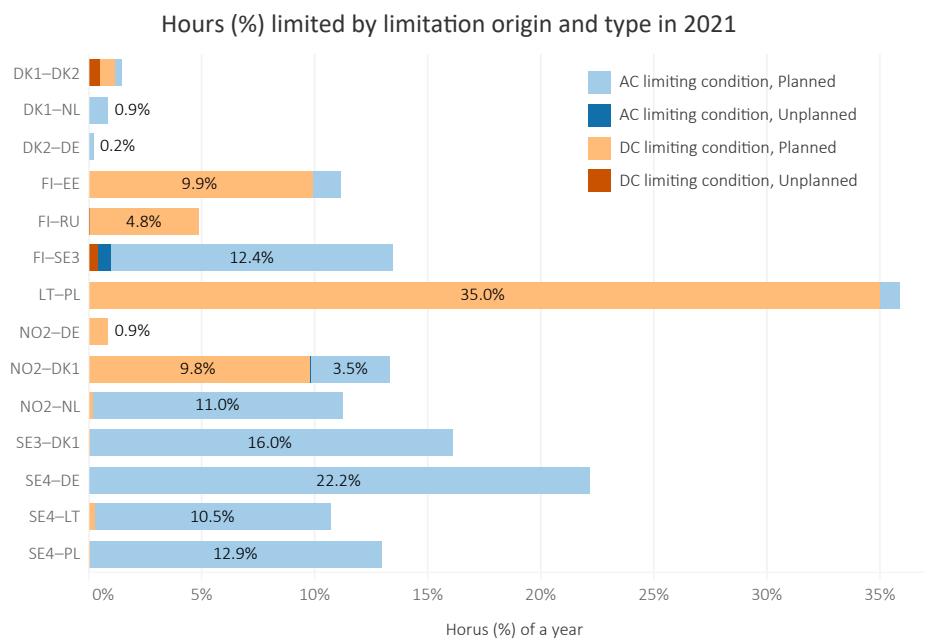
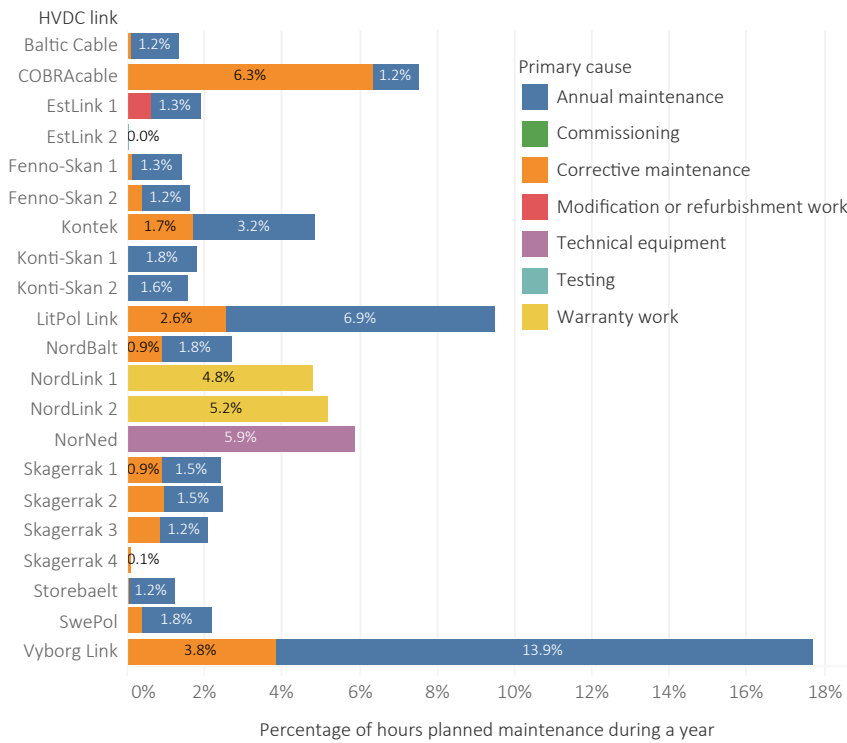

Figure E.6: Hours (%) limited by limitation origin and type for each market connection in 2021. The percentage is calculated by counting the number of hours with the specific limitation origin and type and dividing it by the total number of hours in a year.

Hours (%) with planned maintenance by primary cause in 2021



Annual hours (%) planned maintenance, all HVDC links

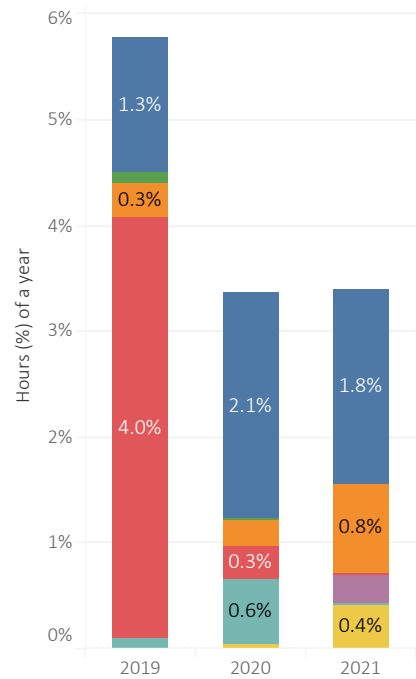

Figure E.7: On the left: hours (%) with planned maintenance by primary cause for each HVDC link in 2021. On the right: hours (%) with planned maintenance by primary cause annually for all HVDC links combined. The percentage is calculated by counting the number of hours with a planned maintenance and dividing it by the total number of hours in a year.

### E.3 Additional figures with origin of event

This section presents additional figures about disturbance and maintenance outages, with a focus on their origin of the event. Origin of event corresponds to the location on the HVDC link that the event originated from. The origin of event categories and subcategories are presented in Appendix B. The HVDC link schematics in Appendix A can be helpful in visualising the categories.

Figure E.8 presents the number of disturbance outages divided by the number of HVDC links annually grouped by origin. Figure E.9 presents the annual unavailable capacity due to disturbance outages by origin of event for all HVDC

links combined. Last, Table E.1 presents the numerical values behind Figure E.9 with further subcategorisation of the origin.

Figure E.10 presents the annual unavailable capacity due to maintenance outages by primary cause. Figure E.11 presents the annual unavailable capacity due to corrective maintenances by origin of event for all HVDC links, and the number of corrective maintenances divided by the number of HVDC links annually grouped by origin of event. Primary cause of outages has not been recorder prior to the year 2019.

Number of disturbance outages divided by the number of HVDC links by origin of event

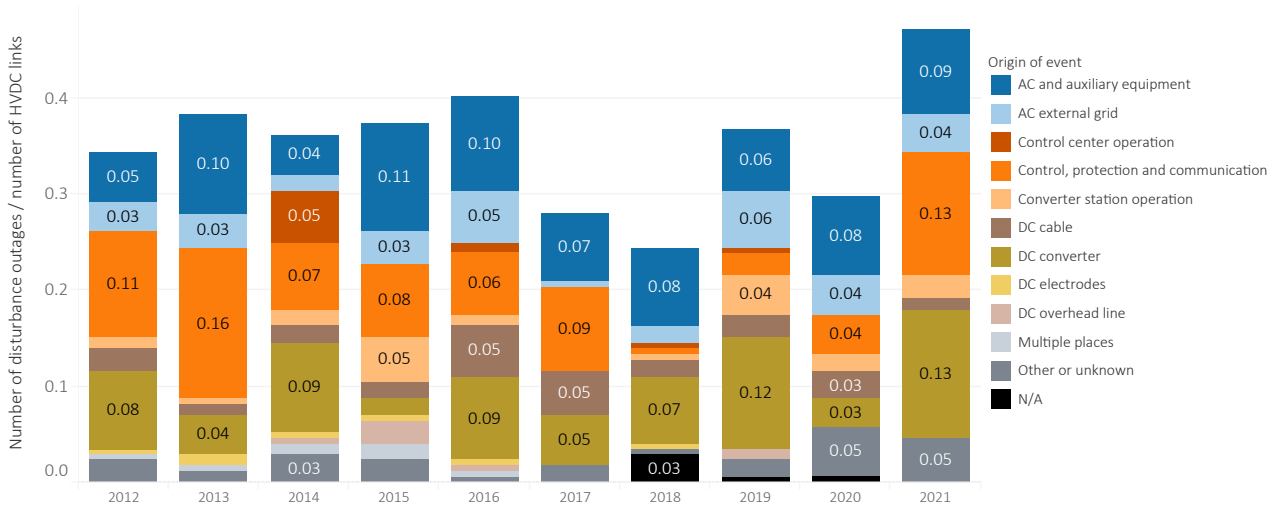

Figure E.8: Number of disturbance outages divided by the number of HVDC links, grouped by origin of event.

Annual unavailable capacity due to disturbance outages by origin of event

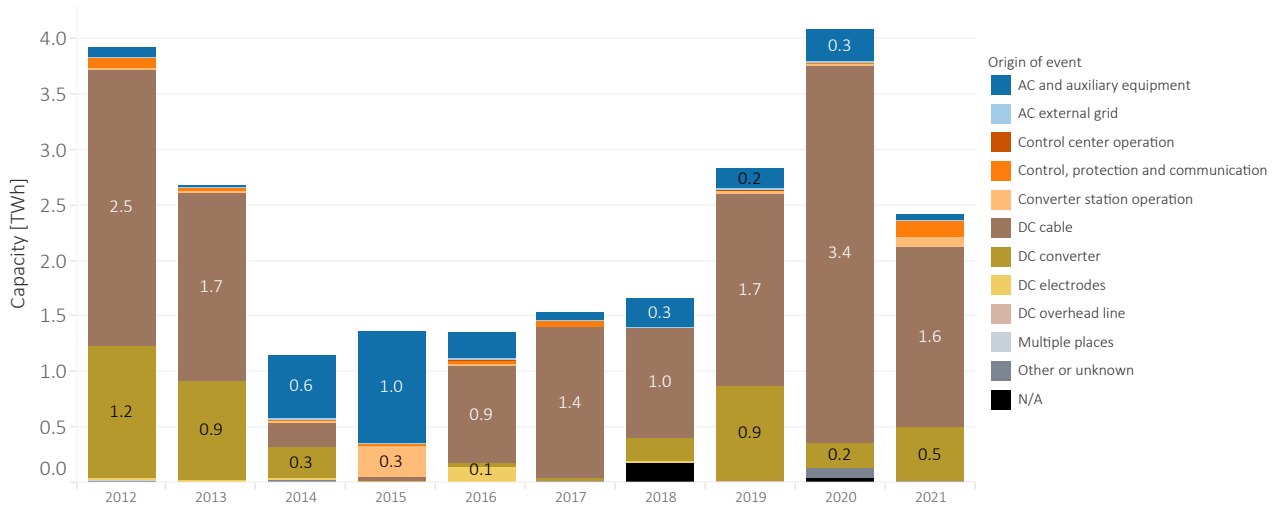

Figure E.9: Annual unavailable capacity due to disturbances outages by origin of event for all HVDC links.

**Table E.1: Annual unavailable capacity due to disturbances outages by origin of event and subcategory for all HVDC links. N/A means not available. Note that the level of detail in the data collection has increased since 2019.**

Origin	Subcategory	GWh									
		2012	2013	2014	2015	2016	2017	2018	2019	2020	2021
AC and auxiliary equipment	AC-E.AX - Auxiliary Equipment and Auxiliary Power	-	-	-	-	-	-	-	1.5	280.1	12.9
	AC-E.CP - AC Control and Protection	-	-	-	-	-	-	-	15.0	3.6	6.7
	AC-E.F - AC Filter and Shunt Bank	-	-	-	-	-	-	-	0.1	0.6	0.1
	AC-E.SW - Other AC Switchyard Equipment	-	-	-	-	-	-	-	0.2	1.1	18.6
	AC-E.TX - Converter Transformer	-	-	-	-	-	-	-	168.7	0.2	3.3
	N/A	93.9	13.5	556.5	1005.9	228.9	65.2	260.5	0.8	1.3	1.1
AC external grid	EXT - External AC System	-	-	-	-	-	-	-	8.0	9.2	4.9
	N/A	11.4	10.4	1.9	6.2	13.6	0.5	2.2	-	-	9.1
Control center operation	N/A	-	-	5.1	-	9.6	-	0.2	0.0	-	-
Control, protection and communication	C-P.L - Local HVDC Control & Protection	-	-	-	-	-	-	-	6.8	10.3	106.2
	C-P.M - Master HVDC Control & Protection	-	-	-	-	-	-	-	-	6.6	37.3
	C-P.T - Control & Protection and Telecommunicati..	-	-	-	-	-	-	-	-	0.7	-
	N/A	79.8	38.3	23.1	12.6	26.3	63.5	0.6	2.7	-	1.3
Converter station operation	C-P.L - Local HVDC Control & Protection	-	-	-	-	-	-	-	21.1	0.8	84.2
	C-P.M - Master HVDC Control & Protection	-	-	-	-	-	-	-	8.2	0.6	-
	N/A	0.4	5.9	2.3	290.4	20.1	-	1.5	-	-	-
DC cable	TL-C - DC Underground / submarine Cable	-	-	-	-	-	-	-	1729.1	3410.9	1623.7
	N/A	2505.5	1704.1	226.9	32.2	876.0	1361.8	996.5	-	-	-
DC converter	DC-E.F - DC Filters	-	-	-	-	-	-	-	-	-	0.1
	DC-E.ME - DC Measuring Equipment	-	-	-	-	-	-	-	65.2	3.6	148.3
	DC-E.O - Other DC Yard and Valve Hall Equipment	-	-	-	-	-	-	-	2.8	-	18.6
	DC-E.SR - DC Smoothing Reactor	-	-	-	-	-	-	-	245.3	174.5	-
	V.C - valve capacitor	-	-	-	-	-	-	-	36.5	-	-
	V.E - Valve Electrical	-	-	-	-	-	-	-	36.9	33.6	217.0
	V.VC - Valve Cooling	-	-	-	-	-	-	-	52.8	13.5	91.4
	N/A	1192.2	888.1	283.0	3.3	37.2	33.8	210.6	424.4	-	12.4
DC electrodes	N/A	3.2	18.4	6.8	9.0	136.3	-	4.6	-	-	-
DC overhead line	TL-OH - DC Overhead Transmission Line	-	-	-	-	-	-	-	3.1	-	-
	N/A	-	-	0.6	3.0	2.3	-	-	-	-	-
Multiple places	N/A	24.3	2.1	0.2	0.2	0.7	-	-	-	-	-
N/A	N/A	-	-	-	-	-	-	186.5	0.7	42.8	-
Other or unknown	O - Other	-	-	-	-	-	-	-	0.0	4.5	1.2
	N/A	13.2	0.9	34.5	1.4	0.7	8.4	0.7	3.1	83.1	17.1

Annual unavailable capacity due to maintenance outages by primary cause

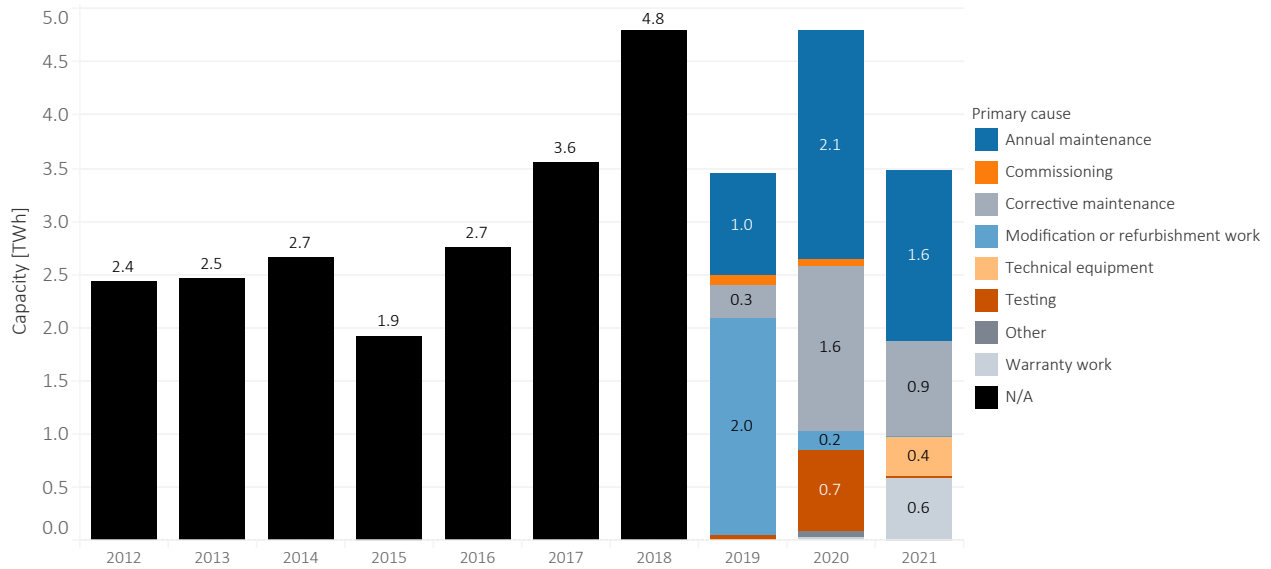

Figure E.10: Annual unavailable capacity due to maintenance outages by primary cause for all HVDC links. Primary cause of outages has not been recorded prior to 2019.

Annual unavailable capacity due to corrective maintenance by origin of event

Number of corrective maintenances divided by number of HVDC links, by origin of event

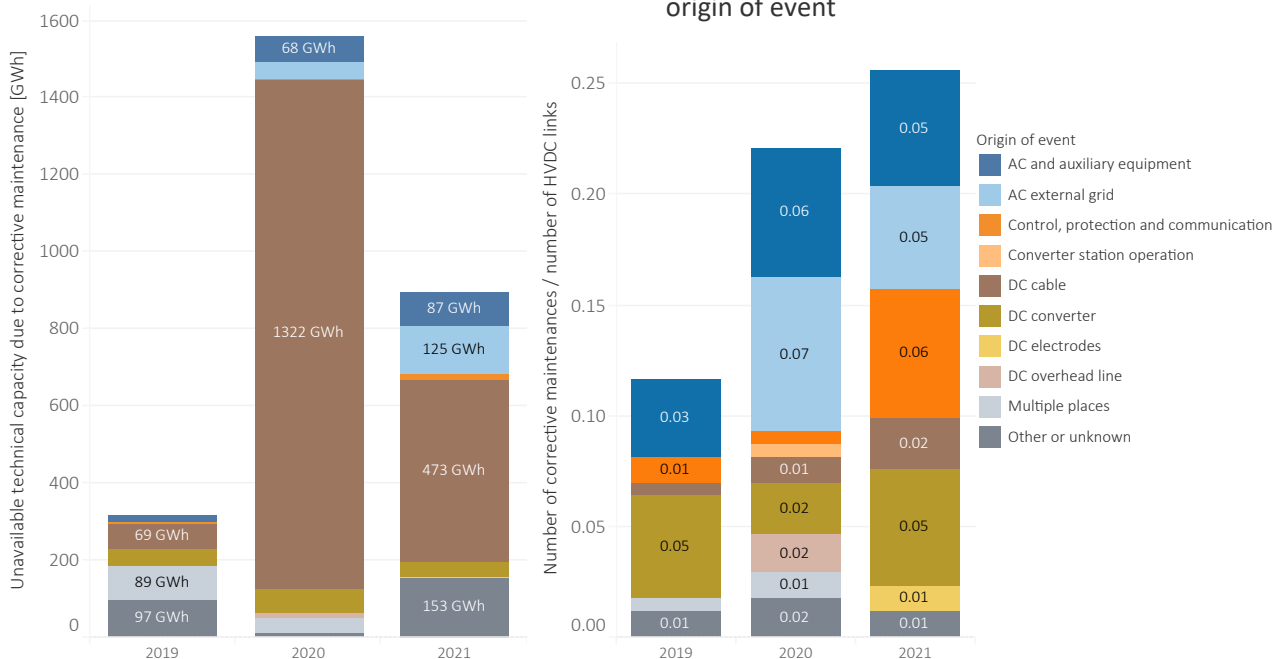

Figure E.11: On the left: annual unavailable capacity due to corrective maintenance outages by origin of event for all HVDC links. On the right: number of corrective maintenance outages divided by the number of HVDC links annually grouped by origin of event. Primary cause of outages has not been recorder prior to the year 2019.