









Grid Code Modification		At what stage is this document in the process?
<h1>Storage Expert Group:</h1> <h2>Final Report</h2>		<div style="border: 1px solid black; padding: 5px; transform: rotate(-15deg); background-color: #e6f2ff;"> <p>Subject to final editing:</p> <ul style="list-style-type: none"> - Transfer to new template (similar to the one of EG MCS) - Update of links/hyperlinks - Include document control and members list </div> <div style="display: flex; flex-direction: column; align-items: flex-end;"> <div style="border: 1px solid black; padding: 2px; margin-bottom: 5px;">05 Draft Grid Code Modification Report</div> <div style="border: 1px solid black; padding: 2px;">06 Final Grid Code Modification Report</div> </div>
<p>Purpose: The Grid Connection ESC Expert Group was established to consider the way in which Storage plants are dealt with by the three European Connection Network Codes (RfG, HVDC and DCC) and, where applicable, to make recommendations on how such equipment should be treated. This is on the basis that Storage equipment (other than Pumped Storage Plant) is explicitly excluded from those Connections Network Codes and against a background of a significant growth in this area over the last few years.</p>		
	This document contains the final report of the Expert Group which ran from October 2018 to April 2019.	
	High Impact: Relevant System Operators, Owners of Storage Plant, Generators and Demand Customers who integrate Storage into their sites	
	Medium Impact	
	Low Impact	

Contents		 Any questions?
1 Introduction	4	Contact: Expert Group Chair
2 Purpose	4	
3 Timetable	6	
4 Technologies, Applications and Topologies	7	
5 Definitions	10	Ioannis Theologitis ENTSO-E
6 Technical Requirements	14	
7 Standards applicable to Storage	18	ioannis.theologitis@entsoe.eu
8 Compliance	18	
9 National Implementation Approaches	19	
10 Interaction with other Expert Groups	22	
11 Examples	22	
12 Recommendations	22	
Annex 1: Approved Terms of Reference	24	
Annex 2: Membership list and attendance	24	
Annex 3: Supplementary Information	24	

About this Document

This is the final report of the Storage Expert Group (EG), established by the Grid Connection European Stakeholder Committee in summer 2018 to consider the suitability of the European Connection Network Codes (CNC) which includes Requirements for Generators¹ (RfG), the

¹ <https://eur-lex.europa.eu/legal-content/EN/TXT/PDF/?uri=CELEX:32016R0631&from=EN>

HVDC Code² and the Demand Connection Code³ (DCC) to storage. It is acknowledged that when the CNCs were drafted the requirements applicable to storage (other than Pumped Storage⁴) were explicitly excluded from these three Codes. The aim of this report is therefore to identify the need for technical requirements for storage and how these requirements would coincide with the existing Network Codes for connection. This may best be achieved based on (i) identification of storage technologies, applications and topologies, (ii) definitions and (iii) different storage categories.

Document Control

Version	Date	Author	Change Reference
0.1	19 Feb 2018	Antony Johnson	First draft

² <https://eur-lex.europa.eu/legal-content/EN/TXT/PDF/?uri=CELEX:32016R1447&from=EN>

³ <https://eur-lex.europa.eu/legal-content/EN/TXT/PDF/?uri=CELEX:32016R1388&from=EN>

⁴ Defined in RfG Article 2(21).

1 Introduction

On 11 June 2018, the Grid Connection European Stakeholder Committee (GC ESC) decided to establish three Expert Groups (EGs) to consider and clarify the requirements for particular groups of Users as applicable under the three European Connection Network Codes (Requirements for Generators, HVDC and Demand Connection).

The areas to be considered were:

- Pumped Storage (hydro);
- Storage; and
- Mixed Customer Sites (MCS), where these could be a combination of generation, demand and/or storage facilities.

The creation of these EGs was proposed by ENTSO-E to elaborate on the three European Connection Network Code (CNC) issues which had been raised by stakeholders during the implementation of the CNCs including as a result of a stakeholder survey to identify priority topics in which future revisions to the three CNCs could be considered.

The full terms of reference for the Storage EG as approved by the 14 Sept 2018 GC ESC are provided in Annex 1.

2 Purpose

Objectives

The objectives of the Expert Group on Storage are:

- Identify storage technologies, applications and topologies;
- Investigate the possibility of a useful definition of storage devices which could lead to the definition of connection requirements at EU level (due to cross-border relevance); and
- Categorize storage devices (if reasonable).

This report will only deal with connection requirements. Wider issues such as operational requirements which overlap with other European Codes such as the System Operator Guideline⁵ will be noted but these issues need to be considered as part of a separate group.

Task description

The three European Connection Network Codes (RfG, HVDC and DCC) explicitly exclude Storage technologies other than in respect of Pumped Storage.

⁵ <https://eur-lex.europa.eu/legal-content/EN/TXT/PDF/?uri=CELEX:32017R1485&from=EN>

In recent years, there has been a substantial increase in the use of electrical system connected storage applications to the extent that some form of connection requirements are necessary. This need is to ensure that relevant system operators can continue to operate safe, secure and economic networks, the requirements upon developers are reasonable, proportionate and non-discriminatory and the definitions are clear. These are all fundamental pre-requisites which are necessary to facilitate Union wide trade in electricity, ensure security of supply, facilitate the integration of renewable energy sources, increase competition and allow the more efficient use of the network and resources for the benefit of consumers.

Discussion with stakeholders have revealed some questions related to storage devices, especially regarding the connection requirements for such units, because of the growth of energy storage projects. The EG Storage has been tasked to consider the following actions:

- identify energy storage technologies and topologies: for each case of application (including in combination with other system users), present penetration, growth potential and main characteristics;
- categorize the different storage technologies: depending on their cross-border impact at the electrical grid connection point characterized (e.g. facility size, functionalities, robustness, protection settings, etc.) while taking into account the findings from the previous point;
- identify relevant functional applications for storage devices: Limited frequency sensitive mode at overfrequency/underfrequency (LFSM-O/U), Frequency Sensitive Mode (FSM), Demand Response (DSR), Fault Ride Through, Reactive Capability, Voltage Control, voltage stability, ramping rates etc.; and
- define if/how these applications could be implemented by standalone storage devices, in association with other system users (e.g. storage devices as part of a new or existing power generating facility or demand facility).

In addition the EG Storage also sought to achieve the following objectives:-

- Include the status regarding RfG requirements / other requirements (from DCC, HVDC);
- How co-located sites are treated;
- Include material presented to the group including experiences from Member States and European trade groups such as EASE (European Association for Storage of Energy);
- Make reference to the EG on Mixed Customer Sites (MCS);
- Consider the Standards applicable to Storage;
- Recommendations; and
- Prepare a report to be circulated to the GC ESC for discussion.

To meet these goals, the Expert Group Storage should be guided by the objectives of the European Connection Network Codes and take into account existing examples from Member States at a National level.

In principle, the group discussed the issues of ownership and agreed that ownership should not have any impact on the technical requirements if a storage unit is connected to TSOs, DSOs, or CDSOs.

As part of the discussions, it was noted that there are some forms of storage technologies which cannot be controlled, for example – Synchronous Flywheels, Synchronous Compensators and Regenerative braking systems. Whilst it is acknowledged that these technologies can store energy, they can only supply or absorb energy under specific conditions (for example under changing frequency conditions, when a train is braking or simply in terms of supplying reactive power). As such, these technologies would be considered to fall outside the scope of the EG Storage Workgroup.

Deliverables

A proposal for the definition and categorization of storage devices, their functional applications and the technical requirements applicable to storage devices.

3 Timetable

The set-up of this Expert Group by the GC ESC was on the basis of delivery of a final report in 6 months from October 2018. A timeline of events is given below.

Approval of Terms of Reference for three expert groups by GC ESC	14 September 2018
Issue of revised ToRs, set-up of Expert Groups	5 October 2018
First meeting of Storage EG – set out work	15 October 2018
Second meeting – Treatment, Standalone configurations, technical requirements, GB examples	23 November 2018
Third meeting – Presentation by EASE and experience in Germany	20 December 2018
Fourth meeting – Definition of Synchronous and Non-Synchronous Electricity Storage Modules – Treatment of Storage as a subset of Generation	25 January 2019
Fifth meeting – Review draft report and populated spread sheet of requirements on a technology specific basis	21 February 2019
Sixth meeting – Physical meeting – Review detailed report contents	18 March 2019
Joint physical meeting with MCS and PSH EG – Status of the storage EG presented to others EG, exchanges	20 March 2019
Seventh Meeting - finalise and submit report	18 April 2019
Approval of report by GC ESC	June 2019?

4 Technologies, Applications and Topologies

One of the main issues with storage is the huge array of different technologies and connection topologies. Storage technologies could take a number of forms; be it compressed air energy storage driven by a synchronous generator, battery storage or a wide variety of other storage devices. In addition, the problem is further compounded by whether the technology considered should concentrate on energy storage, electricity storage or both. In addition, the experience from across Europe has shown there are a wide range of connection configurations in which storage technologies connected to the electrical network could form a standalone device or be integrated with new or existing power generating or demand facilities. These issues were usefully put into context at the first meeting with a presentation given by the European Association for Storage of Energy (EASE) which provided a wide summary of the different technologies available using chemical, mechanical, thermal or electrochemical means. The wide variation in storage technologies is shown in Figure 1.0. The full presentation, from which Figure 1.0 is taken, is included in Annex 3.

2. Energy Storage Technologies – Overview

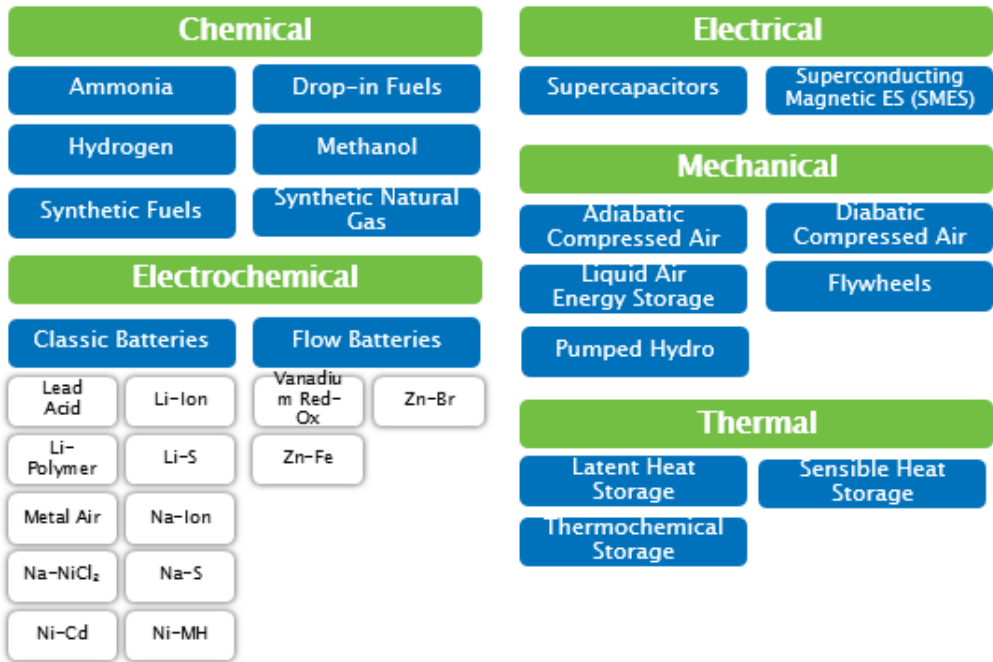

Figure 1.0

This presentation was useful for EG Storage in considering issues such as available markets (e.g. the use for storage either for balancing purposes) or for the provision of Ancillary Services (such as frequency response). As part of this presentation, it was quickly noted that these technologies generally fell into two categories either being connected to the electrical grid Synchronously or Asynchronously.

A part of these discussions one point was noted very quickly in that ‘energy storage’ is quite different to ‘electricity storage’. As the the three European Connection Network Codes (RfG, HVDC and DCC) applies only to electricity, then any form of storage device which solely takes electricity from the electrical network and converts it into another

energy form (e.g. mechanical energy or heat), without re-converting that energy at a later stage back into electricity at the same connection point, would generally be treated as demand, not electrical storage.

The Workgroup discussed the issue of Power to Gas which covers a range of technologies shown in Figure 1.0. An illustration of ‘energy storage’ could be power to gas storage when the gas which is produced from electricity is used for purely gas alone. A good example of this would be an electrolysis plant used for the production of hydrogen from electrical energy. The hydrogen produced is then used as a vehicle fuel and not reconverted back into electricity for use on the electrical system at the same connection point.

Electricity storage on the other hand is where electrical energy is taken from the network, is converted into another form of energy which is stored and then subsequently re-converted back into electrical energy. Taking the above example of power to gas again, this could be where gas is produced from the electricity at that connection site (say for example as part of an industrial process, and the gas is then subsequently converted back to electricity at the same connection site).

In the EG Storage discussions, it seemed appropriate that this would form the basis of a definition for ‘electricity storage’ and that ‘energy storage’ would simply be treated as demand (including ordinary demand as well as any flexible demand that is providing demand response services, both within and outside of the scope of the DCC) In the case of demand response services offered as services to the TSO or RSO, the related requirements of the DCC would apply.

The EG Storage also discussed the modes of operation which for storage these fall into three main areas – these being (i) charge, (ii) discharge and (iii) neutral (neutral being where the storage unit is neither charging or discharging).

The second issue that the EG Storage considered was the wide variety of connection topologies. For example, of the many different technologies, storage could be developed as a standalone facility (connected either at a transmission level or distribution level) in which the facility comprises only of storage devices or as a co-located site where storage is integrated within a new or existing power generating facility or demand facility. A theoretical example of a standalone facility is shown in Figure 2.0 below.

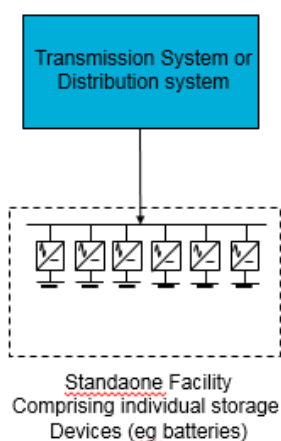

Figure 2.0

For co-located sites, there is quite a substantial variation as it is possible to have storage technologies integrated with a Power Park Module or Synchronous Electricity Storage Module. Though general experience across Europe has tended to favour the installation of batteries with either Power Park Modules or Synchronous Power Generating Modules. For co-located sites, two options become apparent, these being

- i) a co-located site in which the storage device can be independently controlled from the main plant or
- ii) a co-located site where the storage device is a component of the main plant (generation or load and cannot be independently controlled from the main generating plant. In this case, for example, if the main plant (generation or load) is switched off the storage plant would be unable to be used in isolation.

For co-located sites there could be benefits to both the Relevant System Operator and developer. The Relevant System Operator can profit from the additional performances provided by storage technology (e.g. to improve controllability at the specific connection point), while the Developers can use the storage technology to improve performance and optimize the operation of the overall plant. An example of a co-located site is shown in Figure 3.0 (a),(b) and (c).

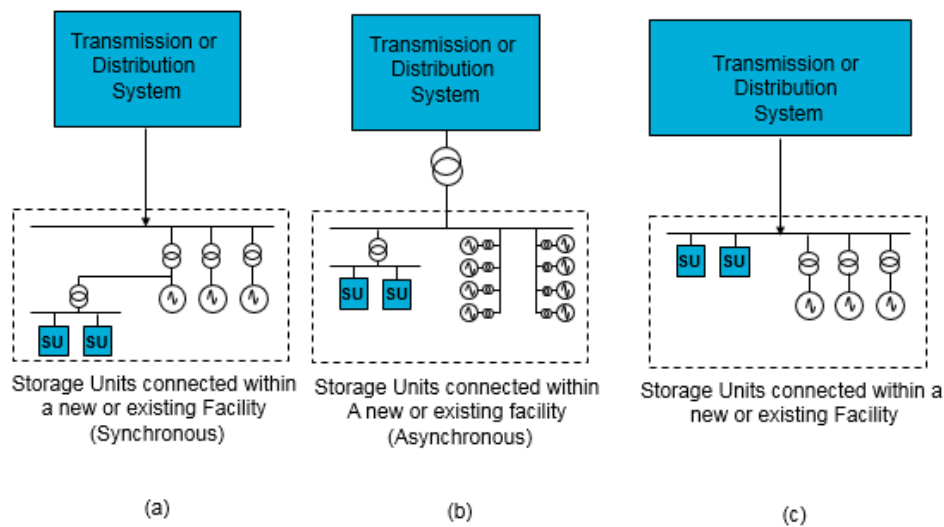

Figure 3.0

Figure 3.0(a) is an example of a component level configuration where the storage devices cannot be independently controlled and Figure 3.0(b) and (c) is where the storage devices could be independently controlled.

In addition, the EG Storage considered a number of other configurations and discussed what constitutes a Storage module. Further examples are shown in Figure 4.0 (a), (b) and (c).

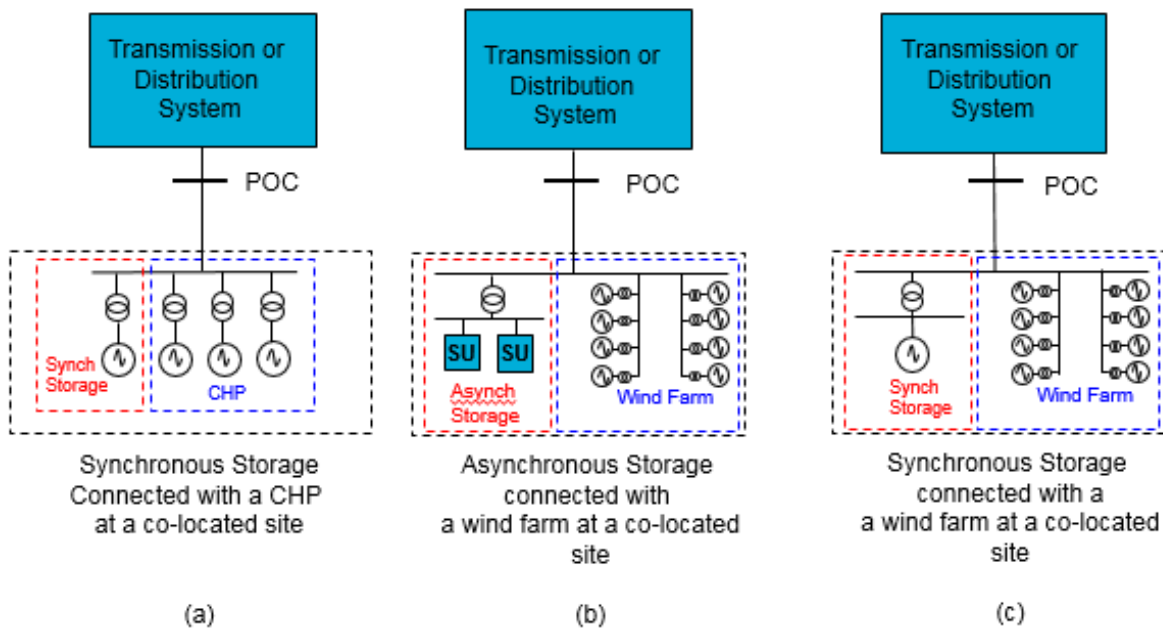

Figure 4.0

POC: point of connection
 CHP: Combined Heat and Power installation

In addition, the EG Storage discussed further connection topologies which are shown in Figure 5.0 (a) and (b).

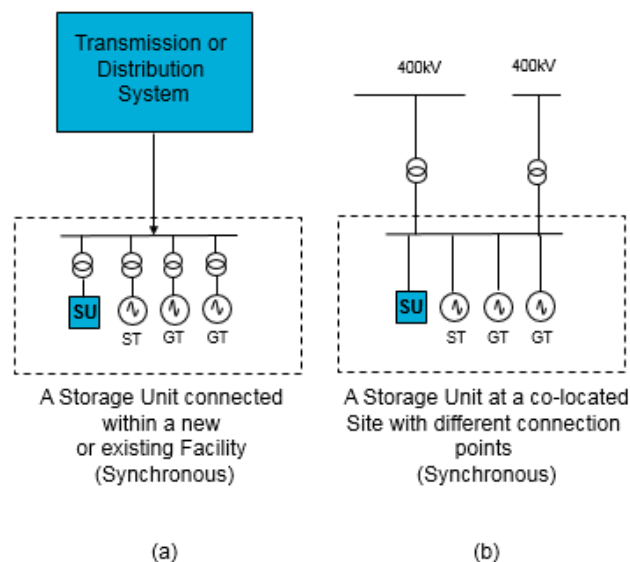

Figure 5.0

5 Definitions

The Expert Group discussed the general issues associated with the definitions relating to Storage. As noted above in section 4, it was considered that any storage plant which uses electrical energy and converts it into another form without then being reconverted back to electrical energy would be treated solely as demand (which includes flexible

demand and is capable of providing demand response services) and hence this falls outside the scope of this work by EG Storage.

A useful definition of 'electricity storage' was then proposed which initially was taken from the work undertaken in GB but in summary can be defined as follows:-

Electricity Storage;- “The conversion of electrical energy into a form of energy which can be stored, the storing of that energy and the subsequent reconversion of that energy back into electrical energy”.

In addition, as part of the EG Storage discussions, and as detailed in section 6 of this report (technical requirements) most of the technologies as listed in Annex 3 – Technical Requirements - fall into two categories, these being either (i) Synchronous storage technologies or (ii) Non- Synchronous storage technologies.

A Synchronous Storage technology would be one where the storage plant is connected to the Grid directly through a Synchronous Power Generating Module and a Non-Synchronous Storage technology would be one directly connected to the electrical grid either partly or in full via a power electronic converter or via an asynchronous generator. This classification is important as there are close linkages here with the definitions used in RfG to the point that storage (notwithstanding the additional demand elements that would be required) start to become a subset of generation and treated in a similar way to Pumped Storage⁶.

To this end, the Expert Group developed the following definitions:

A Synchronous Electricity Storage Module would be one in which the Storage Module converts electrical energy into a form of energy which can be stored, the storing of that energy and the subsequent re-conversion of that energy into electrical energy. The transfer (i.e. charging or discharging) of that electrical energy would be through one or more synchronous machines connected to the electrical network with a single connection point to the system.

Note : while saying connected to the electrical network with a single connection point, that means to be able to charge/discharge through a single connection point (an Electric Vehicle can be connected to different charging stations, depending on its location, but once it's connected to a charging station, the EV is able to charge or discharge from this connection point).

In summary, a Synchronous Electricity Storage Module could be comparable to the same requirements of those of a Synchronous Power Generating Module under RfG.

A Non-Synchronous Electricity Storage Module would be one in which the Storage Module converts electrical energy into a form of energy which can be stored, the storing of that energy and the subsequent re-conversion of that energy into electrical energy. The transfer (i.e. charging or discharging) of that electrical

⁶ As defined in RfG.

energy would be through an asynchronous machine or through a power electronic converter connected to the electrical network with a single connection point to the system.

Note : while saying connected to the electrical network with a single connection point, that means to be able to charge/discharge through a single connection point (an Electric Vehicle can be connected to different charging stations, depending on its location, but once it's connected to a charging station, the EV is able to charge or discharge from this connection point).

*In summary, a Non - Synchronous Electricity Storage Module could be comparable to the same requirements to those of a Power Park Module under RfG. An **Electricity Storage Module** is either a **Synchronous Electricity Storage Module** or a **Non-Synchronous Electricity Storage Module**.*

Under RfG the current definition of Connection Point⁷ could easily be adapted to include electricity storage as follows:-

“Connection Point means the interface at which the power generating module, demand facility, distribution system, HVDC system or electricity storage module is connected to a transmission system, offshore network, distribution system, including closed distribution systems or HVDC System as identified in the connection agreement”.

The EG agreed to check if the above-mentioned definitions fit with the proposed definition from the Clean Energy Package (CEP).

The CEP states that 'energy storage' means, in the electricity system, deferring the final use of electricity to a later moment than when it was generated or the conversion of electrical energy into a form of energy which can be stored, the storing of that energy, and the subsequent reconversion of that energy back into electrical energy or use as another energy carrier.

- “the conversion of electrical energy into a form of energy which can be stored, the storing of that energy, and the subsequent reconversion of that energy back into electrical energy” :

This case of application is addressed by the EG Storage definitions.

An electrochemical storage (battery) connected to the electrical network through power electronics could be an example of this.

- “the conversion of electrical energy into a form of energy which can be stored the storing of that energy, and that technology is used as another energy carrier” :

This would not result in the reconversion of that energy into electrical energy at that Connection Point, it's seen as a load at the connection point because it absorbs power and therefore this case of application would be treated as Demand under DCC in addition to any requirements introduced by national regulations (the scope of DCC is not covering distribution connected demand).

⁷ As defined in Article 2 (15) of RfG.

A chemical storage (such as a gas cavern) where the gas, which was produced from electrical energy, is then used for pure gas use could be an example of demand (not storage). This is covered in the power to gas example described in the third paragraph of section 2 above.

In addition, the Expert Group considered the definitions associated with different storage topologies but in general the Expert Group considered the following approach as reasonable.

It was noted as part of the discussion that a number of the definitions did not match up with various standards. However, this issue equally applies to the other Connection Network Codes (RfG, HVDC and DCC) and so it was agreed that to retain consistency. The issue should be noted but the text across the CNCs should not be changed.

Co-located

A co-located site would be where storage and generation or demand/load is installed at the same facility. However, this then further divides into two categories, these being:-

Supplementary Component – A Generating Unit or a Demand Unit or Distribution Unit in which the operation of the storage device is linked to the operation of the generating unit/demand unit and the storage Module cannot be independently controlled. For example, the use of the Storage device is used by the developer to comply with RfG requirements (e.g. FSM) when modernising an existing generating unit or a new unit is constructed. In that case, when the main component is off, the storage device should also be off.

Note: this supplementary component could be shared between different generating modules or demand facilities at the same installation or between different demand units in the same facility.

Independently Controlled/Operated Component – A facility where there is a generating unit/demand unit and a storage device, but where the operation of the storage device is independent from the operation of other parts of the facility. In that case, it is possible to have the storage device running when the other component(s) of the facility is (are) switched off.

Note: it could be possible to use the same storage device for both applications (supplementary component and independently controlled): a storage device could be partly used to support a generating unit or demand unit, and partly to provide services; or a storage device could be used to support such a unit when this unit is running and could be used independently when the unit is not running. In this case the storage device would have to comply with the requirements for independently controlled devices.

Standalone

A facility comprising solely of storage units which are controlled as one or more Electricity Storage Modules.

The EG Storage also noted the definitions from the GB experience which defines the concept of an Electricity Storage Module and Electricity Storage Unit. In GB the construct is slightly different due to the complication of the Offshore Transmission arrangements but the general approach is to define an Electricity Storage Module which comprises one or more Synchronous or Non Synchronous Electricity Storage Units which then become a subset of the definition of a Synchronous Power Generating Module or Power Park Module.

The importance of this approach is that it means that storage can virtually be treated in the same way as generation under RfG but with the appropriate definitions used to place additional requirements on storage plant – for example low frequency demand disconnection etc. This issue is discussed further in Section 6 – Technical Requirements.

Although technically outside the scope of the Expert Group, electric vehicles have been mentioned. The group acknowledge this requires further thought, however as an initial view, the following approach could be considered as an appropriate way forward.

The concern is that an electric vehicle is effectively a mobile battery with a potentially different network connection point each time it connects to recharge (or discharge). In the case of a large scale installation which comprises many charging stations (for example a motorway service station, long stay carpark, railway station or airport) it makes sense to place the obligation on the connection point facility owner as it is assumed that such a facility would not only provide an ability to recharge the battery but also offer demand response services as well.

The facility will have a set number of charging stations which effectively define its maximum injection/maximum absorption and the facility owner will have the ability; in operational timeframes; to simply trade that injection/absorption based on the number of vehicles in the facility at any one time. The key point here is that the requirement is based on the facility at the connection point and not on the individual vehicle(s) at this location.

When the vehicle(s) moves to another facility, the requirements then get picked up by that new facility at that facility's connection point with the technical requirements being based on the capacity of that facility. In the event of few vehicles being at the facility, this would be equivalent to a wind farm of a certain capacity on a no wind day.

Whilst the Expert Group Storage discussed this approach, it would however require more thought to ensure that such an approach is robust under all scenarios.

6 Technical Requirements

The technical requirements are an essential ingredient to this work, but the general approach adopted by EG Storage is that the technical requirements applicable to storage should be equitable and consistent with other classes of plant such as Generation (RfG), HVDC or Demand (DCC).

Put simply, storage is either Generation and/or Demand⁸ and bearing in mind that storage neatly drops into the two basic categories of a Synchronous Electricity Storage Module or Non - Synchronous Electricity Storage Module, it seems appropriate that RfG with any appropriate elements from DCC / HVDC Codes act as useful starting point for the necessary technical requirements. A more detailed summary of the proposed technical requirements are detailed in Annex 3 – Technical Requirements - however, a brief summary of the technical requirements which are believed to be appropriate to all storage technologies is summarised below in Table 1.0. In general, the same kind of requirements are needed for synchronous and non-synchronous storage modules in addition to related DCC / HVDC requirements. The differences on how to implement those requirements in the two types of technology are detailed in Annex 3.

Requirement	Synchronous	Non-Synchronous
Frequency Range	Y	Y
Voltage Range	Y	Y
General Requirements	Y	Y
Simulation Models	Y	Y
Reactive Capability	Y	Y
Output Power with falling frequency	Y	Y
Black Start (Not Mandatory)	Y	Y
Island Operation	Y	Y
Frequency Response	Y	Y
Voltage Control	Y	Y
Neutral Earthing	Y	Y
Frequency and Voltage Deviations	Y	Y
Frequency, rate of change of frequency and voltage protection setting arrangements	Y	Y
Fault Ride Through	Y	Y
Fast Fault Current Injection	Y	Y
Frequency Sensitive Relays and load shedding or switching from import to export under low frequency conditions	Y	Y

⁸ As set out in the RfG, HVDC or DCC respectively.

Operational Metering	Y	Y
Data Communication and Instructor Facilities	Y	Y
Monitoring	Y	Y

Table 1.0

The Expert Group agreed that whilst most of the requirements fall under the umbrella of RfG, there are a few requirements such as low frequency demand disconnection under DCC (during importing modes of operation), and active power control (ramping, switching) under HVDC⁹. In addition, Article 15 (3) of the Emergency and Restoration Code requires the capability for Storage to switch from a mode analogous to Demand to a mode analogous to generation under falling system frequency conditions with the cycle times and setpoint being defined by the TSO. Where the energy storage unit is not capable of switching from demand to generation mode in the time allocated by the TSO then automatic disconnection is required.

The Emergency and Restoration Code falls outside the Connection Network Codes and hence technically falls outside the scope of this work. Nevertheless, this is an important issue which the workgroup considered as part of its discussions. It was also noted that, the contribution to wider system issues such as balancing also needs to be put in context in terms of the benefits which storage can contribute to the electrical system.

Under an exporting mode of operation (i.e. equivalent to a generator) the plant would have to meet the requirements of RfG in respect of LFSM-O¹⁰ for rising frequency and power output will falling frequency in respect of low frequencies¹¹. In addition, the requirements of RfG Article 15 (2) (frequency response) would apply.

In the case of the storage module acting as Demand (or load), then the initial view of the workgroup was for the Low Frequency Demand Disconnection requirements in DCC (article 19) to apply when the system frequency falls¹². Under DCC Article 19 applies to both transmission connected demand facilities and transmission connected distribution systems. Where system frequency rises continued operation of the demand or load would be assumed.

As highlighted above, under Article 15 (3) of the Emergency and Restoration Code, the requirement exists for storage plant to be capable of switching from import to export under

⁹ HVDC article 13

¹⁰ As set out in RfG Article 13(2)(b).

¹¹ See for example RfG Articles 13(3), (4) and (5).

¹² DCC article 19 in case of TSO-connected storage acting as demand. For DSO-connected storage acting as demand, the requirements will depend on the LFDD scheme of the DSO.

falling frequency with the cycle time and set point determined by the TSO. Where this time cannot be met the storage unit should be tripped. The workgroup discussed this and noted the following issues:-

- The effect on the System
- Control System Stability issues
- Differences in cycle times between different storage technologies (eg a battery will have a very different cycle time than a mechanical storage system such as a compressed air energy storage system)
- Existing plant may struggle with these requirements especially as Storage is not codified in the Connection Network Codes

Whilst it is acknowledged that this requirement is in the Emergency and Restoration Code, one solution could be for the TSO to set a very short cycle time so that under low frequency conditions tripping is automatically initiated in the same as low frequency demand disconnection.

The Expert Group then considered two further issues. If RfG was to be used as the primary mechanism to define the technical requirements, should the same banding thresholds as used in RfG (i.e. Type A, Type B, Type C and Type D which is Member State specific) also be applicable to storage. The Expert Group believe this to be reasonable on the basis of (i) equitable treatment with other technologies (ii) storage being potentially treated as a subset of generation and (iii) in the case of co-located sites the co-existence of storage and generation would necessitate the size thresholds to be equitable.

The second point raised was that under DCC, Articles 27 – 30 define the requirements for demand response providers to meet certain requirements but only should they wish to offer demand response services. There is an argument to support this on the basis that when the storage equipment is operating in the demand mode, then such services could be provided, however they would need to be consistent with DCC.

The general approach suggested by the EG Storage was that Electricity Storage would be best treated as a subset of generation and have to meet the same requirements as RfG – set out within an Appendix to the RfG which specifically defines any additional requirements applicable to storage which Power Generating Modules would not need to comply with.

One final point noted by the Expert Group related to simulation models. In summary, as storage was to be classified into the two broad classifications of Synchronous Electricity Storage Modules and Non-Synchronous Electricity Storage Modules, which map to Synchronous Power Generating Modules and Power Park Modules plus any additional demand related simulation requirements, it was agreed that the most appropriate solution would be to use the same approach used in RfG. In other words, where the storage plant is coupled to the network through a synchronous machine a synchronous machine model should be used and where the storage plant is coupled to the network through a Power Park Module is used the appropriate model (e.g. converter or asynchronous machine model) should be used. As to whether load flow, dynamic or electromagnetic time domain studies are used would depend on what application but from a System Operator's perspective all of the above would likely be required and where necessary specified. In that respect the principle of simulation model submission is the same as the other CNCs.

In the case of mode changes between import and export under low frequency conditions where this is required or low frequency demand disconnection this functionality would be expected to be included as part of the simulation models.

7 Standards applicable to Storage

The Expert Group discussed the standards applicable to storage. These include:-

EN50549-1 and -2

Applicable for LV and MV connection

Based on RfG requirements (+other requirements based on the needs regarding DSO connections

Storage included (ESS) Synchronous and Non Synchronous Categories – implicitly applicable for storage

IEC Standards IEC 62933 / 62786

Define requirements for connection of storage devices, state of approval
IEC 62933 is currently under preparation - linkage between IEC 62933 / 62786

IEC 62933-1 standard gives the following definitions:

Electrical Energy Storage (EES): The installation is able to absorb electrical energy, to store it for a certain amount of time and to release electrical energy during which the energy conversion processes may be included.

Electrical Energy Storage System (EES system or EESS): A Grid-connected installation with defined electrical boundaries, comprising at least one electrical energy storage unit, which extracts electrical energy from an electric power system, stores this energy internally in some manner and injects electrical energy into an electrical power system and which includes civil engineering works, energy conversion equipment and related ancillary equipment

8 Compliance

The compliance provisions applicable to storage would be expected to be consistent with those for Generation, HVDC and Demand, as set out in the respective three European Connection Codes¹³.

In the case of storage, the only element where this is likely to be different is in the case of a co-located site at the component level (i.e. where the storage element cannot be

¹³ RfG, HVDC and DCC.

independently controlled from the main plant). In this case, it is assumed that compliance would be with respect to the main plant (which could be generation or storage). Thus, for a Power Generating Module, it would take into account the capacity of the complete module. For example, in the case of a co-located installation comprising a generator and storage module and the storage module cannot be independently controlled from the Power Generating Module, (i.e. the storage module is used to improve the performance of the generating plant - e.g. providing enhanced FSM capability or reactive power capability,) compliance would be assessed on the total Maximum Capacity of the installation (e.g. if the Maximum Capacity of the Power Generating Module is 100MW and the Maximum Capacity of the Storage Module is 20MW, then compliance would be assessed on a total Maximum Capacity declared by the Generator which would be 120MW). On the other hand it is likely that the Generator as plant owner may wish to declare the maximum capacity of the installation (Storage and Power Generating Module) to be 100MW in which case compliance would be assessed on a maximum capacity of 100MW.

On another hand, if the objective is to install a storage plant on an existing facility (generation or demand), which could be independently controlled from the main component, the compliance would be assessed independently on the storage plant and separately on the generation/demand unit.

9 Examples of how the technical requirements for Storage have been considered by a number of Member States

As part of the Expert Group discussions, a number of Member States have been developing their own requirements and approaches to storage. Some of them summarised below.

GB

In GB the issue of how the national Grid Code should treat storage technologies has been under development for some time. This first started with a couple of workshops in August 2016 and then developed into a full Grid Code Workgroup in January 2017 (GC0096). The national group initially took the view to treat storage in the same way as other User's such as Generation, Demand or HVDC.

The initial work ran in parallel with RfG implementation, however it was agreed that following the implementation of RfG, similar requirements should apply to Storage. Full

details of the work including the presentations, documents and legal text are available from the following link.

<https://www.nationalgrideso.com/codes/grid-code/modifications/gc0096-energy-storage>

The drafting has been subject to an industry consultation and having been re-submitted to the GB Grid Code Review Panel is now the subject of a Code Administrator consultation ahead of submission to the NRA for a decision.

In summary, the approach adopted is to treat storage as a subset of generation which would have to meet the same requirements as generators who are required to satisfy the requirements of RfG plus additional requirements for the demand elements. Details of the GB experience are detailed in Annex 3 of this report.

Germany

In Germany, VDE|FNN defines in the technical connection rules requirements for connection and parallel operation with the electrical grid, that fulfil both the EU specifications and the specifics for the German electric power system. Users that comply with these national codes of practice will also adhere to the European Network Codes. The following technical rules are applicable for storage as a part of the National Standardisation Document Set: VDE-AR-N 4100, VDE-AR-N 4105, VDE-AR-N 4110, VDE-AR-N 4120, VDE-AR-N 4130 (available also in English).

The German technical connection rules distinguish between voltage levels since the requirements for grid connection depend on them. Storage / storage systems are explicitly included into the scope of these technical rules. Moreover, they have separate paragraphs with specific requirements.

France

In France the work on connection requirements for storage technologies is just starting.

The main technology identified is electrochemical storage (battery) connected to the electrical network through power electronics. As this technology could be comparable to PV plant regarding grid connection, the approach would be to start from RfG requirements (PPM) and to work on similar requirements. The work would then be extended to other technologies.

Belgium

In Belgium technical requirements for storage have been discussed on 2 levels.

The first level is that of the transmission system, for which there is a Federal Technical Grid Code. This code has been amended thoroughly due to e.g. the requirements stemming from the network codes and guidelines. The text is running through the last stages of the approval process, but will be published as a Royal Decree, probably still before Summer 2019.

This Federal Technical Grid Code contains now technical connection requirements for connection of storage to the transmission grid only and which are very similar and some identical to the NC RfG requirements.

The TSO proposed those requirements in a first stage in May 2018 at the same time as the general requirements (non-exhaustive requirements) for NC RfG, NC DCC and NC HVDC to the Federal service covering energy and can be found on the TSO's website, publicly available:

http://www.elia.be/~media/files/Elia/users-group/WG%20Belgian%20Grid/20180522_Voorstel-Elia-aangaande-Federaal-Technisch-Reglement/5-Proposal-for-Storage-Connection-Requirements_final.pdf

The second level is that of the distribution systems, for which the requirements for the connection of storage devices are included in the C10/11 prescriptions of the DSOs (C10/11 = specific technical requirements for decentralised generation working in parallel on the distribution grid).

This C10/11 prescription has equally gone through a very important review, mainly due to the new standards EN 50549-1 and -2 on which the C10/11 is based and of course also due to the new requirements in the NC RfG.

Since EN 50549-1 and -2 cover storage requirements, the new C10/11 also covers in the same way requirements for storage devices.

C10/11 document is also in its final stages of approval by the regional regulators in Belgium and will soon be available to all stakeholders.

Netherlands

In the Netherlands, the work on connection requirements for storage technologies hasn't been started yet.

Till now, the technical connection rules are still projected with respect to the connection point.

For generators or demand behind the connection point (at the customers side), compliance is with respect to RfG and DCC.

If there is storage on the customer side, then there is asked for compliance to the grid codes on the connection point, compared to the behaviour of the storage component.

ITALY

In Italy the technical requirements for connecting to the network are described in three main documents: CEI 0-21 for LV system, CEI 0-16 for MV system and TERNA Grid Code for HV system.

The technical requirements for storage system are already described in such documents, including their definition and testing procedure.

The approach used in the Italian standards is unit based rather and the requirements that applies to the storage system has to be considered as for the single unit, exception made when they are connected on the DC side of the inverter. In this case the inverter will be the focus point of the requirements.

It has to be said that, as described in the definitions of the CEI standards, the storage definition ("Sistema di Accumulo") is related to chemical storage (batteries) connected to the grid using a dedicated inverter.

The testing procedure is basically structured in a similar format of the other technologies and permits the certification of family products.

The standards are continuously evolving and CT316 committee very active.

Here is the links to the CEI website where the CEI can be downloaded:

<https://www.ceinorme.it/it/norme-cei-0-16-e-0-21.html>

Here is the link to TERNA Grid Code (English):

<https://www.terna.it/en-gb/sistemaelettrico/codicedirete.aspx>

10 Interaction with other Expert Groups

It was agreed that there was overlap between the work of the Expert Group Storage and the Expert Group Mixed Customer Site. A future development has also considered if there should be any overlap with the Expert Group Pumped Storage (Hydro).

For co-located sites where generation and storage could exist side by side, it was suggested that the recommendations on co-located sites should be forwarded to the Expert Group Mixed Customer Sites and co-ordinated as part of the overall Expert Group meetings held in March 2019.

11 Examples

The workgroup discussed a range of examples which are available from the attached link.

Link to be inserted

12 Recommendations

The recommendations of the Expert Group Storage based on the evidence presented are as follows:

- 1) The Expert Group Storage considers that Electricity Storage is best defined as “*the conversion of electrical energy into a form of energy which can be stored, the storing of that energy and the subsequent reconversion of that energy back into electrical energy*”.

Electricity Storage Modules effectively can be treated as two types, these being Synchronous Electricity Storage Modules or Non- Synchronous Electricity Storage Modules. When exporting energy, a Synchronous Electricity Storage Module would be treated in the same way as a Synchronous Power Generating Module and a Non-Synchronous Electricity Storage Module would be treated in the same way as a Power Park Module. This leads to the definition that *“An Electricity Storage Module is either a Synchronous Electricity Storage Module or a Non-Synchronous Electricity Storage Module”*.

- 2) Where Energy Storage plants exist (i.e. they simply convert electricity into another energy medium for onward conversion without re-converting that energy into electrical energy at that connection point) then this would be treated as demand or a demand response service(s).

Note: The current scope of application of DCC doesn't cover demand units connected to a DSO or CDSO unless they provide demand response services.

- 3) The Expert Group agreed that two broad connection configurations exist, these being (i) a standalone site where the facility comprises solely of storage modules which are controlled as one module or a group of modules or (ii) a co-located site which comprises either (a) storage integrated with a generating or demand facility and the storage unit can be independently controlled from the main plant or (b) the storage unit is inherently linked to the operation of the main plant and cannot be independently controlled within the facility.
- 4) The Expert Group believe that it is appropriate for certain forms of electricity storage devices to be excluded from the requirements– for example Synchronous Flywheels, Synchronous Compensators and Regenerative braking systems.
- 5) The Expert Group agreed that operational and data requirements applicable to storage fall outside the scope of this CNCs related work (as operational and data matters fall within the other, non-connection related, European Network Codes).
- 6) The Expert Group agreed that technical requirements shouldn't take into account ownership of storage units.
- 7) The Expert Group agreed that technical capabilities should be included into the connection network codes. Then the way to use those capabilities will be described in the operational network codes.
- 8) The Expert Group discussed electric vehicles and agreed this was technically out of scope but an initial view was that any requirements should be based on the connection point rather than the electric vehicle itself.
- 9) The Workgroup discussed the capability of storage units from changing mode from import to export under low frequency conditions which is a requirement of the Emergency and Restoration Code. The workgroup highlighted some issues over this requirement but also noted that where the TSO defined a short cycle time tripping could be used as an alternative.

Annex 1: Approved Terms of Reference

The approved terms of reference are available from the attached link.

Link to be inserted (Ioannis – can you help with this ie link the EG Storage Sharepoint site)

Annex 2: Membership list and attendance

The membership list from the various meetings is available from the attached link.

Link to be inserted (Ioannis – can you help with this ie link the EG Storage Sharepoint site)

Annex 3: Supplementary Information

Useful background information including a spread sheet of proposed technical requirements and the information presented at the EG Group Storage meetings is available from the attached link.

Link to be inserted (Ioannis – can you help with this – ie link the EG Storage Sharepoint site)